

Service Bulletin No: 57-016

Ref No: 125

Modification No: INSPECTION

ATA Chapter: 57

**WINGS - GENERAL
INSPECTION OF THE LEFT AND RIGHT AILERON OUTBOARD BEARING-BRACKETS****1. Planning Information****A. Effectivity**

PC-9 aircraft MSN 101 thru MSN 248 and MSN 501 thru MSN 567 without Service Bulletin 57-017 accomplished.

All outboard-aileron bearing-bracket assemblies (bracket assembly), P/N 557.22.09.279 (LH) and P/N 557.22.09.280 (RH) held as spare, in stock or installed on spare wings.

B. Concurrent Requirements

None.

C. Reason**(1) Problem**

An Operator has found cracks in the outboard aileron bearing-bracket (bracket), P/N 557.22.09.281 (LH) and P/N 557.22.09.282 (RH) installed on some of his aircraft. If the rivets in the affected location come out, they could cause the aileron to become jammed or lost in flight.

NOTE: The brackets, P/N 557.22.09.281 (LH) and P/N 557.22.09.282 (RH) are part of the bracket assembly, P/N 557.22.09.279 (LH) and P/N 557.22.09.280 (RH).

(2) Cause

The cause of the cracks is stress corrosion.

It is possible for stress corrosion cracks to occur in brackets, P/N 557.22.09.281 (LH) and P/N 557.22.09.282 (RH) made of aluminium alloy 2024-T351. These cracks would occur in the areas around the attachment fasteners.

Initially the material specification of the brackets, P/N 557.22.09.281 (LH) and P/N 557.22.09.282 (RH) was aluminium alloy 2024-T351. The material specification was subsequently changed to aluminium alloy 2124-T851 to decrease the risk of damage from stress corrosion. The part number was not changed when the new material specification was introduced.

(3) Solution

Do an eddy-current conductivity measurement-test to identify the material specification of the brackets, P/N 557.22.09.281 (LH) and P/N 557.22.09.282 (RH). If the brackets, P/N 557.22.09.281 (LH) and P/N 557.22.09.282 (RH) are made of aluminium alloy 2024-T351 and not replaced (Ref. Service Bulletin 57-017), do an eddy-current inspection in the areas around the attachment fasteners.

NOTE: If you find a crack in one of the bearing brackets, P/N 557.22.09.281 (LH) or P/N 557.22.09.282 (RH) made of aluminium alloy 2024-T351, you must replace the left and right brackets (Ref. Service Bulletin 57-017) before the next flight.

The Aircraft Maintenance Manual (AMM) will be updated to include a 150 hour eddy-current crack detection of all aluminium alloy 2024-T351 brackets, P/N 557.22.09.281 (LH) and P/N 557.22.09.282 (RH).

Operators that have the bracket assemblies, P/N 557.22.09.279 (LH) and P/N 557.22.09.280 (RH) replaced with new bracket assemblies, P/N 557.22.09.547 (LH) and P/N 557.22.09.548 (RH) or have identified the installed bracket assemblies (P/N 557.22.09.279 (LH) and P/N 557.22.09.280 (RH)) as aluminium alloy 2124-T851, do not need to do the scheduled eddy current test.

D. Description

(1) This Service Bulletin gives the data and instructions necessary to do:

- A one time eddy-current conductivity measurement-test
- If necessary, a one time eddy-current inspection for cracks.

(2) This Service Bulletin also gives the necessary instructions:

- if cracks are found
- if no cracks are found.

E. Compliance

Mandatory.

Required within one calendar month after the effective date of this Service Bulletin, unless already accomplished.

F. Approval

The technical content of this Service Bulletin is approved under the authority of Letter of DOA Acceptance ref. FOCA.21J.002.

Pilatus advises Operators/Owners to check with their local Airworthiness Authorities for any changes, local regulations or sanctions that may affect the embodiment of this Service Bulletin.

G. Copyright Information

© Pilatus Aircraft Ltd. This document contains proprietary information that is protected by copyright. All rights are reserved. No part of this document may be copied, reproduced or translated to other languages without the prior written consent of Pilatus Aircraft Ltd.

H. Manpower

	Total
Preparation	2.25
Eddy-current conductivity measurement-test	0.50
Eddy-current inspection for cracks (If necessary)	1.00
Close up	2.25
TOTAL MAN-HOURS	6.00

NOTE: Man-hours figures do not include the time required to cure sealants, paints and adhesives.

I. Weight and Balance**(1) Weight Change**

Not applicable.

(2) Moment Change

Not applicable.

J. Electrical Load Data

Not changed.

K. Software

Not changed.

L. References

Aircraft Maintenance Manual (AMM), 20-31-00, 25-10-00, 27-00-00, 27-10-01.

M. Publications Affected

AMM, 05-05-01, 05-12-01, 57-21-00.

Structural Repair Manual (SRM), 57-21-00.

N. Interchangeability of Parts

Not applicable.

2. Material Information**A. Material - Price and Availability**

Operators who require more information should contact:

PILATUS AIRCRAFT LTD,
CUSTOMER LIAISON MANAGER,
CH 6371 STANS, Tel: +41 41 619 62 26 (Government)
SWITZERLAND Fax: +41 41 619 61 70

Kit Number	Price	Availability
500.60.09.146	Contact address above	Contact address above

NOTE: Kit No. 500.60.09.146 is the kit for the reference pieces used to help identify the type of material the brackets are made from. One kit is required for each fleet of aircraft.

B. Material Necessary for Each Aircraft**(1) Material to be Purchased**

Kit No. 500.60.09.146 has these parts:

PART No.	DESCRIPTION	QTY	REMARKS
513.57.09.149	AA2024-T351 Test Piece	1	
513.57.09.150	AA2124-T851 Test Piece	1	

NOTE: One kit is required for each fleet of aircraft.

(2) Operator Supplied Materials (Ref. AMM 20-31-00)

MATERIAL NO.	DESCRIPTION	QTY	REMARKS
P01-010	SOLVENT	A/R	Or equivalent
P02-031	ABSORBENT PAPER	A/R	Or equivalent
MS20426AD3	RIVET	A/R	See Note

NOTE: Rivet length to be determined on installation.

C. Material Necessary for Each Spare

Not applicable.

D. Re-identified Parts

Not applicable.

E. Tooling - Cost and Availability

PART No.	DESCRIPTION	QTY	REMARKS
-	Eddy-Current Conductivity Measurement Equipment	1	Local supply
-	Eddy-Current Crack Detection Equipment	1	Local supply

3. Accomplishment Instructions - On Aircraft and Spare Wings

WARNING: BEFORE YOU GO INTO THE COCKPIT, MAKE SURE THAT BOTH EJECTION SEATS HAVE THE SAFETY PINS INSTALLED IN THE SAFE FOR SERVICING LOCATIONS (REF. AMM, 25-10-00, PAGE BLOCK 201).

WARNING: BE CAREFUL WHEN YOU USE THE CONSUMABLE MATERIALS. OBEY THE MANUFACTURERS HEALTH AND SAFETY INSTRUCTIONS.

A. Preparation

- (1) Put the "DO NOT OPERATE THE FLIGHT CONTROLS" sign near the front and rear cockpits.
- (2) Before you do work on the Flight Control System (FCS), you must do the safety procedures shown in the AMM, 27-00-00, Page Block 201.
- (3) Remove the screws and open the access panels LB15 and RB15.

B. Do the Test to Find the Type of Material

- (1) Obey the manufacturer's operating instructions and calibrate the eddy-current conductivity measurement equipment.
- (2) For the left-aileron outboard bearing-bracket, P/N 557.22.09.281 (Ref. Fig. 1):
 - (a) Remove the dirt and grease from the test area with the absorbent paper (Material No. P02-031) made moist with the solvent (Material No. P01-010).

NOTE: It is not necessary to remove the layers of surface protection to do the test.

- (b) Do the test.

NOTE: The temperature of the wing structure and the test pieces must be the same.

- 1 Put the eddy current probe in position in the test area (shown shaded in the Fig 1).
- 2 Record the value shown on the test equipment.
- 3 Put the eddy current probe on:
 - The AA2024-T351 test piece (P/N 513.57.09.149) and record the value
 - The AA2124-T851 test piece (P/N 513.57.09.150) and record the value.
- 4 Do a comparison of the values recorded on the eddy-current conductivity measurement-equipment for:
 - The left bracket assembly (P/N 557.22.09.279)
 - The AA2024-T351 test piece (P/N 513.57.09.149)
 - The AA2124-T851 test piece (P/N 513.57.09.150).

- (9) Install the three rivets (3) (P/N MS20426AD3) with a countersunk on both sides of the joint.

NOTE: Rivet length to be determined on installation.

- (10) Repair the aircraft external finish.
- (11) Install the aileron (Ref. AMM, 27-10-01, Page Block 401).
- (12) Do Steps 3.C.(1) thru (11) on the other aileron outboard bearing-bracket, (1).

D. Close-Up

- (1) Remove all tools and materials and make sure the work area is clean.
- (2) Close the access panels LB15 and RB15 and install the screws.
- (3) Remove the "DO NOT OPERATE THE FLIGHT CONTROLS" sign.

E. Documentation

- (1) Make an entry in the Aircraft Logbook that this Service Bulletin has been incorporated.
- (2) Make an entry in the Aircraft Logbook that the material type of the left bracket, P/N 557.22.09.281 was determined as either:
 - AA2024-T351
 - or
 - AA2124-T851.
- (3) Make an entry in the Aircraft Logbook that the material type of the right bracket, P/N 557.22.09.282 was determined as either:
 - AA2024-T351
 - or
 - AA2124-T851.
- (4) Use the Service Bulletin Evaluation Sheet and report your results and the serial number(s) of the aircraft to Pilatus.

4. Accomplishment Instructions - Equipment Held as Spare or in Stock**A. Do the Test to Find the Type of Material (Ref. Fig. 1)**

- (1) Obey the manufacturer's operating instructions and calibrate the eddy-current conductivity measurement equipment.
- (2) For the left bracket assembly, P/N 557.22.09.279:

NOTE: It is not necessary to remove the layers of surface protection to do the test.

(a) Do the test.

- 1 Put the eddy current probe in position in the test area (shown shaded in the Fig 1).
 - 2 Record the value shown on the test equipment.
 - 3 Put the eddy current probe on:
 - The AA2024-T351 test piece (P/N 513.57.09.149) and record the value
 - The AA2124-T851 test piece (P/N 513.57.09.150) and record the value.
 - 4 Do a comparison of the values recorded on the eddy-current conductivity measurement-equipment for:
 - The left bracket assembly (P/N 557.22.09.279)
 - The AA2024-T351 test piece (P/N 513.57.09.149)
 - The AA2124-T851 test piece (P/N 513.57.09.150).
 - 5 If the value for the left bracket assembly (P/N 557.22.09.279) is similar to the value recorded for the AA2024-T351 test piece (P/N 513.57.09.149), return the part to Pilatus.

On receipt, Pilatus will send you a new left outboard-aileron bearing-bracket assembly, P/N 557.22.09.547.
 - 6 If the value for the left bracket assembly (P/N 557.22.09.279) is similar to the value recorded for the AA2124-T851 test piece (P/N 513.57.09.150), return the part to stores.
- (3) Do Step 4.A.(2) again on the right bracket assembly, P/N 557.22.09.280. If you have to send this part to Pilatus (Ref. Step 4.A.(2)(a)5, Pilatus will send you a new right outboard-aileron bearing-bracket assembly, P/N 557.22.09.548.

B. Documentation

- (1) Make an entry on the equipment label that this Service Bulletin has been accomplished and the material was found to be AA2124-T851.
- (2) Use the Service Bulletin Evaluation Sheet and report your results.

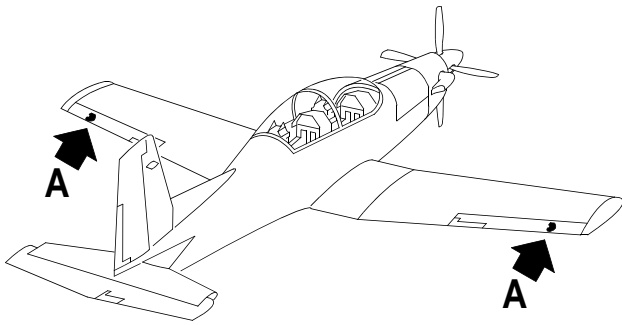

LEFT HAND SHOWN
RIGHT HAND SIMILAR

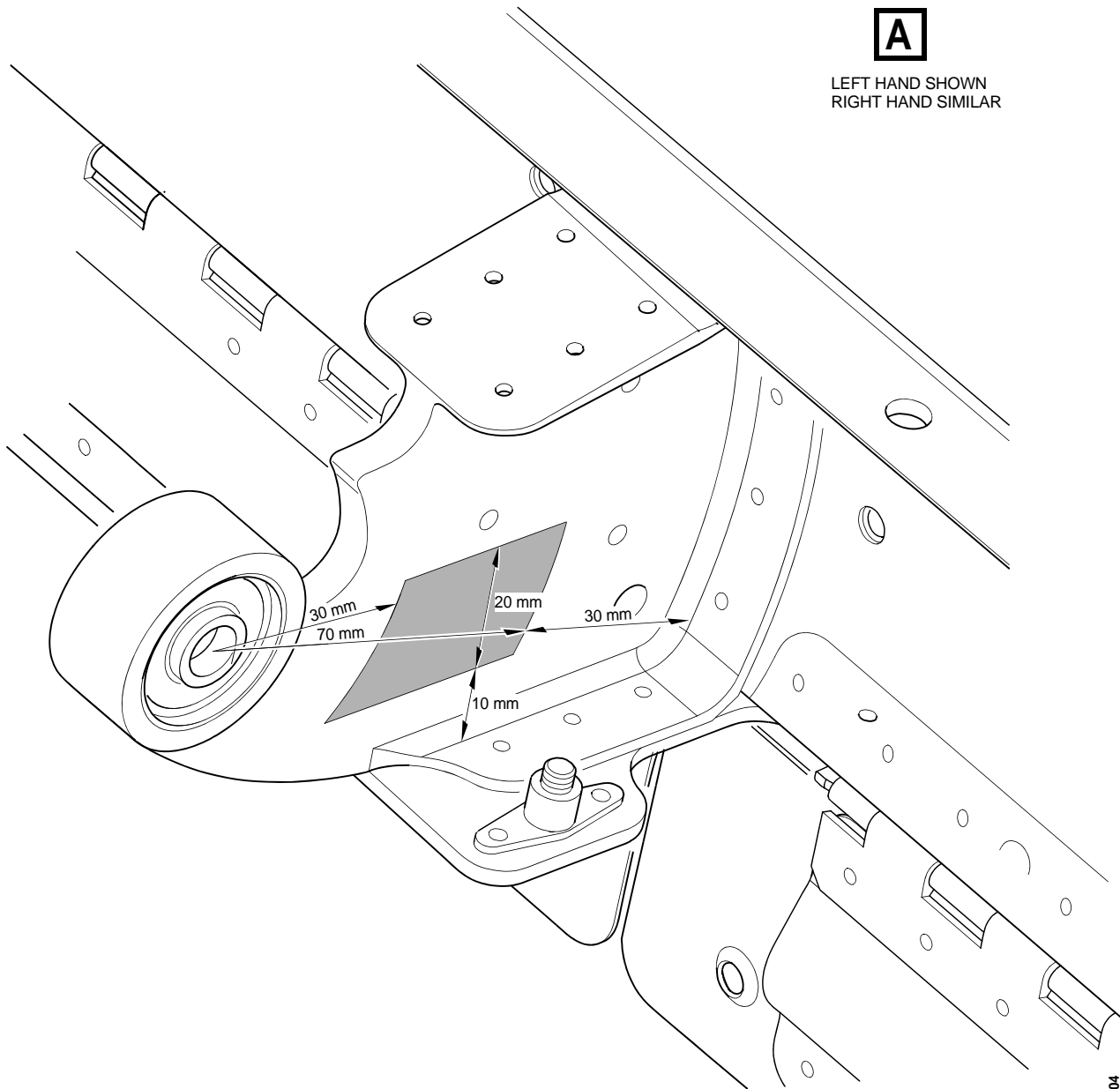

SB 2104

Inspection to Find the Type of Material
Figure 1

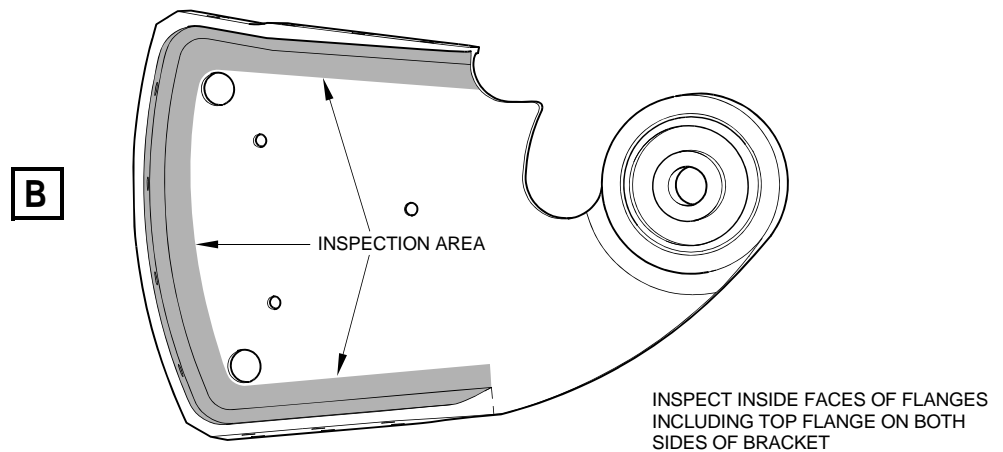
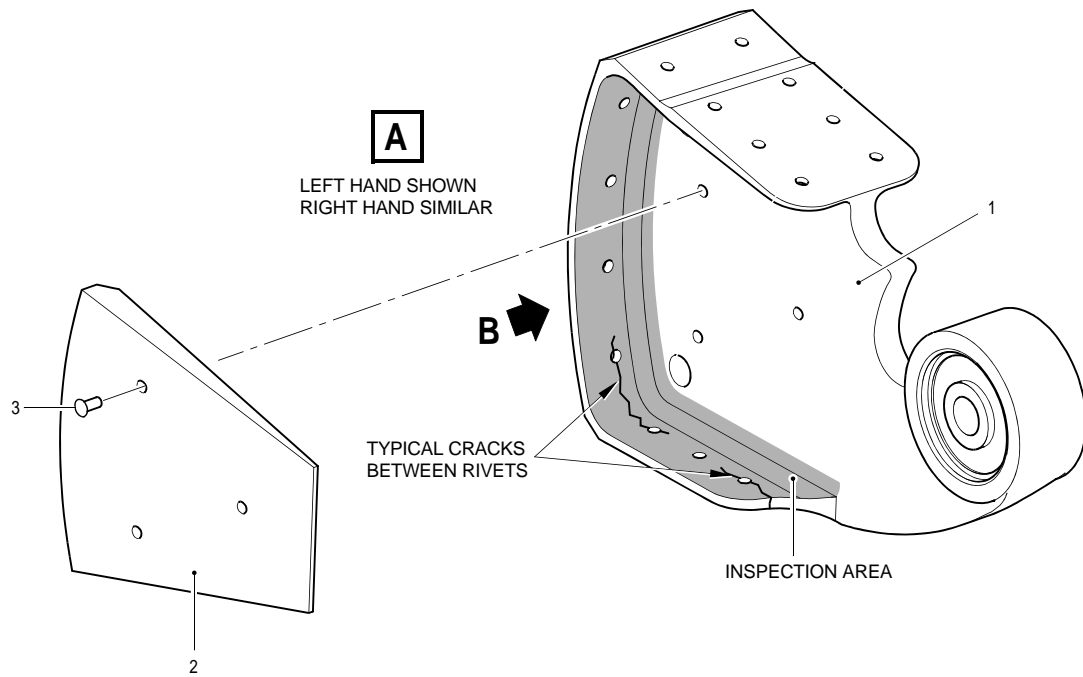
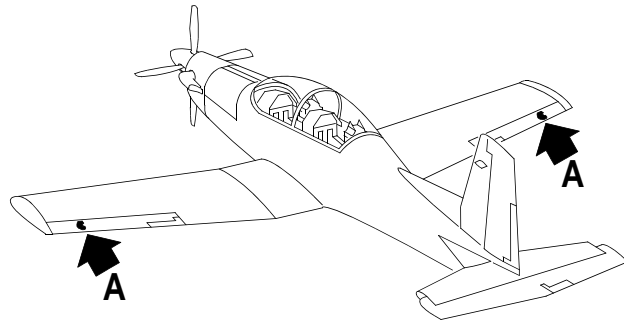

Inspection to find Cracks
Figure 2

INTENTIONALLY BLANK

SERVICE BULLETIN EVALUATION SHEET FOR SB No. 57-016			
Title	Wings - General Inspection of the Left and Right Aileron Outboard Bearing-Brackets		
Customer			
Service Center			
EMBODIMENT REPORTING			
This SB has been embodied:		<input type="checkbox"/>	On the entire fleet
		<input type="checkbox"/>	Only partially
Provide embodiment details per aircraft (use additional copies of this table, if necessary)			
MSN	Flying Hours	MSN	Flying Hours
Additional embodiment comments/findings			
EDITORIAL COMMENTS (procedure, kit quality, suggested improvements, etc.)			
Name	Signature	Date	
Please complete and forward this form to: Pilatus Aircraft LTD, Customer Technical Support (MCC), P.O. BOX 992, 6371 Stans, Switzerland Fax: +41 (0)41 619 6773 Email: Techsupport@pilatus-aircraft.com			

SERVICE BULLETIN EVALUATION SHEET

INTENTIONALLY BLANK