

Service Bulletin No: 51-001

Ref No: 137

Modification No: Inspection

ATA Chapter: 51

AIRCRAFT STRUCTURE - GENERAL**DO A CHECK OF THE MATERIAL SPECIFICATION USED DURING MANUFACTURE AND, IF NECESSARY, DO A CHECK FOR CRACKS OR REPLACE THE PART****1. Planning Information****A. Effectivity**

- (1) MSN 101 thru MSN 248 and MSN 501 thru MSN 567.
- (2) All of these parts, held as spare or in stock:

| ITEM | PARA | PART NUMBER | DESCRIPTION |
|------|------|--------------------------------------|---|
| 1 | 1 | 557.51.09.013 or 557.51.09.101 | AILERON NOSE RIB 1, LH or AILERON NOSE RIB 1 ASSY, LH |
| 2 | 1 | 557.51.09.014 or 557.51.09.102 | AILERON NOSE RIB 1, RH or AILERON NOSE RIB 1 ASSY, RH |
| 3 | 2 | 555.10.09.060 or 555.10.09.059 | ELEVATOR CENTER-ATTACHMENT BEARING-BRACKET or ELEVATOR CENTER-ATTACHMENT BEARING-BRACKET ASSY |
| 4 | 3 | 555.30.09.039 or 555.30.09.040 | RUDDER LOWER-HINGE BEARING-BRACKET or RUDDER LOWER-HINGE BEARING-BRACKET ASSY |
| 5 | 4 | 553.10.09.075 | FRAME 3 PICK-UP BRACKET, LH |
| 6 | 4 | 553.10.09.076 | FRAME 3 PICK-UP BRACKET, RH |
| 7 | 5 | 111.34.07.329 | FLAP BEARING SUPPORT BRACKET, LH |
| 8 | 5 | 111.34.07.330 | FLAP BEARING SUPPORT BRACKET, RH |
| 9 | 6 | 557.31.09.142 | REAR CONTROL-COLUMN SUPPORT-BEARING BRACKET |
| 10 | 7 | 527.30.09.027 or 527.30.09.028 | LEVER or LEVER ASSY |
| 11 | 8 | 527.30.09.015 | ELEVATOR CENTER CONTROL-ROD |
| 12 | 9 | 527.30.09.016 | ELEVATOR REAR CONTROL-ROD |

| ITEM | PARA | PART NUMBER | DESCRIPTION |
|------|------|---|--|
| 13 | 10 | 527.30.09.029 or 527.30.09.030 | BEARING or BEARING ASSY |
| 14 | 11 | 527.30.09.036 | SHACKLE |
| 15 | 11 | 116.35.07.092 | SHACKLE |
| 16 | 12 | 527.10.09.021 | LEFT AND RIGHT AILERON OUTER CONTROL-ROD |
| 17 | 13 | 553.20.09.062 or 553.20.09.231 or 553.20.09.235 | FRONT AND REAR RUDDER-PEDALS OUTBOARD-BEARINGS |
| 18 | 13 | 553.20.09.229 | FRONT AND REAR RUDDER-PEDALS OUTBOARD-BEARING SUPPORT-PLATES |

B. Concurrent Requirements

None.

C. Reason
(1) Problem

Pilatus has highlighted the possibility that some critical parts can crack due to stress corrosion.

(2) Cause

The investigation found that initially the material of the parts was AA2024-T351 which is susceptible to Stress Corrosion Cracking (SCC). The material was subsequently changed to AA2124-T851, a new material with improved mechanical properties. The part number was not always changed when the new material was introduced (Ref. Table 1 - Summary).

| Item | Para | Description | Installed Item P/N before accomplishment of SB | |
|------|------|--|--|---------------|
| | | | AA2024-T351 | AA2124-T851 |
| 1 | 1 | AILERON NOSE RIB 1, LH | 557.51.09.013 | 557.51.09.013 |
| 2 | 1 | AILERON NOSE RIB 1, RH | 557.51.09.014 | 557.51.09.014 |
| 3 | 2 | ELEVATOR CENTER-ATTACHMENT BEARING-BRACKET | 555.10.09.060 | 555.10.09.143 |
| 4 | 3 | RUDDER LOWER-HINGE BEARING-BRACKET | 555.30.09.039 | 555.30.09.039 |
| 5 | 4 | FRAME 3 PICK-UP BRACKET, LH | 553.10.09.075 | 553.10.09.075 |
| 6 | 4 | FRAME 3 PICK-UP BRACKET, RH | 553.10.09.076 | 553.10.09.076 |
| 7 | 5 | FLAP BEARING SUPPORT BRACKET, LH | 111.34.07.329 | 111.34.07.329 |
| 8 | 5 | FLAP BEARING SUPPORT BRACKET, RH | 111.34.07.330 | 111.34.07.330 |
| 9 | 6 | REAR CONTROL-COLUMN SUPPORT-BEARING BRACKET | 557.31.09.142 or 557.31.09.353 | 557.31.09.142 |
| 10 | 7 | LEVER | 527.30.09.027 | 527.30.09.027 |
| 11 | 8 | ELEVATOR CENTER CONTROL-ROD | 527.30.09.015 | 527.30.09.082 |
| 12 | 9 | ELEVATOR REAR CONTROL-ROD | 527.30.09.016 | 527.30.09.083 |
| 13 | 10 | BEARING | 527.30.09.029 | 527.30.09.029 |
| 14 | 11 | SHACKLE | 527.30.09.036 | 527.30.09.036 |
| 15 | 11 | SHACKLE | 116.35.07.092 | 116.35.07.092 |
| 16 | 12 | LEFT AND RIGHT AILERON OUTER CONTROL-ROD | 527.10.09.021 | 527.10.09.073 |
| 17 | 13 | FRONT AND REAR RUDDER-PEDALS OUTBOARD-BEARINGS | 553.20.09.062 or 553.20.09.231 | N/A |
| 18 | 13 | FRONT AND REAR RUDDER-PEDALS OUTBOARD-BEARING SUPPORT-PLATES | 553.20.09.235 | 553.20.09.235 |
| | | | 553.20.09.229 | 553.20.09.229 |

Summary
Table 1

(3) Solution

Do a one time inspection of the parts (both on aircraft and those held in stores) listed in Para. 1.A.(2) to:

- (a) Check the material of the parts.
- (b) If the parts are made from AA2124-T851, make an entry in the aircraft logbook as required in paragraph 3.D.(3).
- (c) If the parts are made from AA2024-T351:

1 For Items 1 thru 9, 11, 12 and 16 thru 18, do a one time inspection for cracks. If cracks are found, contact Pilatus.

NOTE: Mandatory inspections will be added to Chapter 5 of the Aircraft Maintenance Manual (AMM). The inspections will give instructions on how to examine the parts for cracks. The inspections will only be applicable to parts made from AA2024-T351.

2 For Items 10 and 13 thru 15, replace the parts with parts made from AA2124-T851.

D. Description

This Service Bulletin gives the data and instructions necessary to do the:

- (1) Inspection of the Aileron Nose Rib 1.
- (2) Inspection of the Elevator Center-Attachment Bearing-Bracket.
- (3) Inspection of the Rudder Lower-Hinge Bearing-Bracket.
- (4) Inspection of Frame 3 Pick-Up Bracket.
- (5) Inspection of the Left and Right Flap Bearing Support-Bracket.
- (6) Inspection of the Rear Control-Column Support-Bearing Bracket.
- (7) Inspection and, if Necessary, Replacement of the Lever on the Rear Control-Column.
- (8) Inspection of the elevator center control rod.
- (9) Inspection of the elevator rear control rod.
- (10) Inspection and, if Necessary, Replacement of the Bearing in the Forward Control-Column.
- (11) Inspection and, if necessary, Replacement of the Shackles on the Elevator Control Cable.
- (12) Inspection of the left and right aileron outer control-rods.
- (13) Inspection of the Front and Rear Rudder-Pedal Outboard-Bearings and, If Necessary, the Front and Rear Rudder-Pedal Outboard-Bearing Support-Plates.

E. Compliance

Mandatory.

Accomplishment required not later than 365 days after the effective date of this Service Bulletin.

F. Approval

The technical content of this Service Bulletin is approved under the authority of Letter of DOA Acceptance ref. FOCA.21J.002.

Pilatus advises Operators/Owners to check with their designated Airworthiness Authorities for any changes, local regulations or sanctions that may affect the embodiment of this Service Bulletin.

G. Copyright Information

© Pilatus Aircraft Ltd. This document contains proprietary information that is protected by copyright. All rights are reserved. No part of this document may be copied, reproduced or translated to other languages without the prior written consent of Pilatus Aircraft Ltd.

H. Manpower

| | Total | Total | Total | Total | Total |
|---|--------------|--------------|--------------|--------------|--------------|
| Preparation | 20.0 | | | | |
| Inspection | 10.0 | | | | |
| Replacement of the Lever (527.30.09.027) | | 3.0 | | | |
| Replacement of the Bearing (527.30.09.029) | | | 3.0 | | |
| Replacement of the Shackle (527.30.09.036) | | | | 2.0 | |
| Replacement of the Shackle (116.35.07.092) | | | | | 2.0 |
| Close up | 40.0 | | | | |
| TOTAL MAN-HOURS | 70.0 | 3.0 | 3.0 | 2.0 | 2.0 |

I. Weight and Balance

(1) Weight Change

None

(2) Moment Change

None

J. Electrical Load Data

Not changed.

K. Software

Not changed.

L. References

Aircraft Maintenance Manual (AMM), 06-20-00 or 12-00-00, 07-10-00, 08-10-01, 20-31-00, 25-10-00, 25-10-01, 25-30-02, 27-00-00, 27-05-02, 27-10-00, 27-20-01, 27-20-02, 27-30-00, 27-30-01.

Illustrated Parts Catalogue (IPC), 25-10-01, 27-10-01, 27-30-01, 55-10-01, 55-30-01

Structural Repair Manual (SRM), 53-10-00, 53-10-01, 53-10-02, 53-20-00, 53-10-02, 55-10-01, 57-21-00, 57-51-00.

M. Publications Affected

AMM, 05-05-01, 05-12-01.

IPC, 27-10-01, 27-30-01.

SRM, 51-10-01, 53-10-02, 53-20-00, 57-31-00, 57-51-00.

N. Interchangeability of Parts

Not applicable.

2. Material Information
A. Material - Price and Availability

Operators who require further information on Price and Availability should contact their Customer Liaison Manager at:

Pilatus Aircraft Ltd,
6371 Stans,
Switzerland.

Operators are requested to advise Pilatus Aircraft Ltd. of the Manufacturer's Serial Number (MSN), the flying hours and landings of aircraft which are allocated for this Service Bulletin using the Service Bulletin Evaluation Form.

| KIT NUMBER | PRICE | AVAILABILITY |
|---------------|-----------------------|-----------------------|
| 500.50.09.091 | Contact address above | Contact address above |

B. Material Necessary for Each Aircraft
(1) Material to be Purchased

Kit No. 500.50.09.091 has these parts:

| New Part No. | Description | Old Part No. | Qty | Disp. Code | Fig | Item |
|---------------|------------------|---------------|-----|------------|----------------|---------------------------|
| 527.30.09.221 | BEARING ASSEMBLY | 527.30.09.030 | 1 | D | 16 | 2 |
| 527.30.09.223 | LEVER ASSEMBLY | 527.30.09.028 | 1 | D | 15 | 1 |
| 527.30.09.229 | SHACKLE | 527.30.09.036 | 1 | D | 18 | 9 |
| 527.30.09.231 | SHACKLE | 527.30.09.092 | 1 | D | 18 | 12 |
| 940.17.02.340 | COTTER PIN | | 5 | D | 15 16 18 | 17 19 11 6 19 |
| 940.17.02.350 | COTTER PIN | | 2 | D | 15 16 | 9 4 |

Disposition Codes: D - Discard / R - Return to Stores

(2) Operator Supplied Materials (Ref. AMM 20-31-00)

| MATERIAL NO. | DESCRIPTION | QTY | REMARKS |
|--------------|------------------------|-----|---------------|
| P01-010 | SOLVENT | A/R | Or equivalent |
| P02-031 | ABSORBENT PAPER | A/R | Or equivalent |
| P04-028 | GREASE | A/R | Or equivalent |
| P04-039 | CORROSION PREVENTATIVE | A/R | Or equivalent |

C. Material Necessary for Each Spare

Not applicable.

D. Re-identified Parts

If the parts, either installed on the aircraft or held as spare, are made from AA2124-T851, change the part numbers as follows:

| DESCRIPTION | INSTALLED ITEM P/N (AA2124-T851) | RE-IDENTIFIED PART NUMBER |
|---|----------------------------------|---------------------------|
| AILERON NOSE RIB 1, LH | 557.51.09.013 | 557.51.09.221 |
| AILERON NOSE RIB 1, RH | 557.51.09.014 | 557.51.09.222 |
| ELEVATOR CENTER-ATTACHMENT BEARING-BRACKET | 555.10.09.143 | 555.10.09.143 |
| RUDDER LOWER-HINGE BEARING-BRACKET | 555.30.09.039 | 555.30.09.168 |
| FRAME 3 PICK-UP BRACKET, LH | 553.10.09.075 | 553.10.09.855 |
| FRAME 3 PICK-UP BRACKET, RH | 553.10.09.076 | 553.10.09.856 |
| FLAP BEARING SUPPORT BRACKET, LH | 111.34.07.329 | 557.21.09.117 |
| FLAP BEARING SUPPORT BRACKET, RH | 111.34.07.330 | 557.21.09.118 |
| REAR CONTROL-COLUMN SUPPORT-BEARING BRACKET | 557.31.09.142 or 557.31.09.353 | 557.31.09.531 |
| LEVER | 527.30.09.027 | 527.30.09.226 |
| BEARING | 527.30.09.029 | 527.30.09.228 |
| SHACKLE | 527.30.09.036 | 527.30.09.230 |
| SHACKLE | 116.35.07.092 | 116.35.07.232 |
| AILERON OUTER CONTROL-ROD | 527.10.09.073 | 527.10.09.073 |
| ELEVATOR CENTER CONTROL-ROD | 527.30.09.082 | 527.30.09.082 |
| ELEVATOR REAR CONTROL-ROD | 527.30.09.083 | 527.30.09.083 |
| RUDDER-PEDAL OUTBOARD-BEARING | 553.20.09.235 | 553.20.09.436 |
| RUDDER-PEDAL OUTBOARD-BEARING SUPPORT-PLATE | 553.20.09.229 | 553.20.09.437 |

E. Tooling - Cost and Availability

| PART No. | DESCRIPTION | QTY | REMARKS |
|---------------|---|-----|--------------|
| 500.60.09.146 | REFERENCE PLATES KIT | 1 | |
| - | EDDY-CURRENT EQUIPMENT WITH CONDUCTIVITY MEASUREMENT PROBE | 1 | Local supply |
| - | OR CONDUCTIVITY MEASUREMENT EQUIPMENT | 1 | Local supply |
| - | BOROSCOPE | 1 | Local supply |
| - | ALUMINIUM OR STEEL TUBE OF APPROXIMATELY 800 MM LENGTH X 10 MM DIAMETER | 1 | Local supply |

NOTE: Because of the difficult access for some parts, Pilatus recommends that the maximum diameter of the measurement probe is 6,25 mm (0.25 in.).

NOTE: Because of the small access in the control rods, Pilatus recommends that the maximum diameter of the boroscope is 3,29 mm (0.13 in.) with a length of 2 m (78.80 in.).

NOTE: Kit No. 500.60.09.146 is the kit for the reference pieces used to help identify the material of the suspect parts.

NOTE: Kit No. 500.60.09.146 is the same kit used for the accomplishment of Service Bulletin 57-016 and Service Bulletin 53-015. If you have the pieces from that kit, you do not need to procure the kit again.

NOTE: Kit No. 500.60.09.146 has these parts:

| PART No. | DESCRIPTION | QTY | REMARKS |
|---------------|-----------------------------|-----|---------|
| 513.57.09.149 | AA2024-T351 REFERENCE PLATE | 1 | |
| 513.57.09.150 | AA2124-T851 REFERENCE PLATE | 1 | |

3. Accomplishment Instructions - On Aircraft

WARNING: BEFORE YOU GO INTO THE COCKPIT, MAKE SURE THAT BOTH EJECTION SEATS HAVE THE SAFETY PINS INSTALLED IN THE SAFE FOR SERVICING LOCATIONS (REF. AMM, 25-10-00, PAGE BLOCK 201).

WARNING: BE CAREFUL WHEN YOU USE THE CONSUMABLE MATERIALS. OBEY THE MANUFACTURERS HEALTH AND SAFETY INSTRUCTIONS.

NOTE: Read and obey the manufacturers instructions about how to prepare the consumable materials before you use them.

A. Preparation

- (1) Put a warning sign (DO NOT OPERATE THE FLIGHT CONTROLS) in the front and rear cockpits.
- (2) Disengage the flight control lock.
- (3) Before you do work on the Flight Control System (FCS), you must do the safety procedures shown in the AMM, 27-00-00, Page Block 201.
- (4) Install the tail jack and the adapter (Ref. AMM, 07-10-00, Page Block 201).
- (5) Install ballast to the tail mooring point (Ref. AMM, 07-10-00, Page Block 201).
- (6) Remove the front and rear ejection seats (Ref. AMM, 25-10-01, Page Block 401).
- (7) In the front cockpit, open and install a safety clip to the circuit breaker:

BAT SWITCH (BATTERY BUS CB panel).

- NOTE:** For the location of the access items, refer to AMM, 06-20-00, Page Block 1 or 12-00-00, Page Block 1.
- (8) Remove the battery compartment access panel F12.
 - (9) Disconnect the battery hot plug P202.
 - (10) If installed, cut and remove the lockwire from the battery mating connector.
 - (11) Disconnect the battery mating connector.
 - (12) Open the access panel F8.
 - (13) Remove the access panels F13, F14, LB5, RB5, LT9 and RT9.
 - (14) Remove the left and right side panels from the front cockpit to get access to the left and right frame 3 pick-up brackets (Ref. AMM, 25-30-02, Page Block 401).
 - (15) Remove the left and right side panels from the front and rear cockpits to get access to the left and right rudder pedals outboard bearings (Ref. AMM, 25-30-02, Page Block 401).

- (16) Remove the flight control covers in the front cockpit (Ref. Fig. 1):
- (a) Remove the worm-drive clamp and the leather collar (Ref. AMM, 27-05-02, Page Block 401 for more information).
 - (b) Remove the screw, the washer and the P clip, then disconnect the electrical connector (Ref. AMM, 27-05-02, Page Block 401 for more information).
 - (c) Remove the screws (3) and the washers (4).
 - (d) Remove the forward cover (2).
 - (e) Remove the screws (6) and the washers (5).
 - (f) Remove the shroud (1).
- (17) Remove the left and right floor panels from the rear cockpit to get access to the left and right frame 3 pick-up brackets (Ref. IPC, 25-10-01 for more information).
- (18) Remove the flight control covers in the rear cockpit (Ref. Fig. 2):
- (a) Remove the worm-drive clamp and the leather collar (Ref. AMM, 27-05-02, Page Block 401 for more information).
 - (b) Remove the screw, the washer and the P clip, then disconnect the electrical connector (Ref. AMM, 27-05-02, Page Block 401 for more information).
 - (c) Remove the screws (9) and the washers (10) from the top cover (1).
 - (d) Remove the screws (8) and the washers (7) from the top cover (1) and the bottom cover (6).
 - (e) Remove the top cover (1).
 - (f) Remove the screws (3) and the washers (4) from the upper shroud (2) and the lower shroud (5).
 - (g) Remove the upper shroud (2).
 - (h) Remove the lower shroud (5).
 - (i) Remove the bottom cover (6).
- (19) If installed, remove the balance weights (Ref. AMM, 08-10-01, Page Block 401).

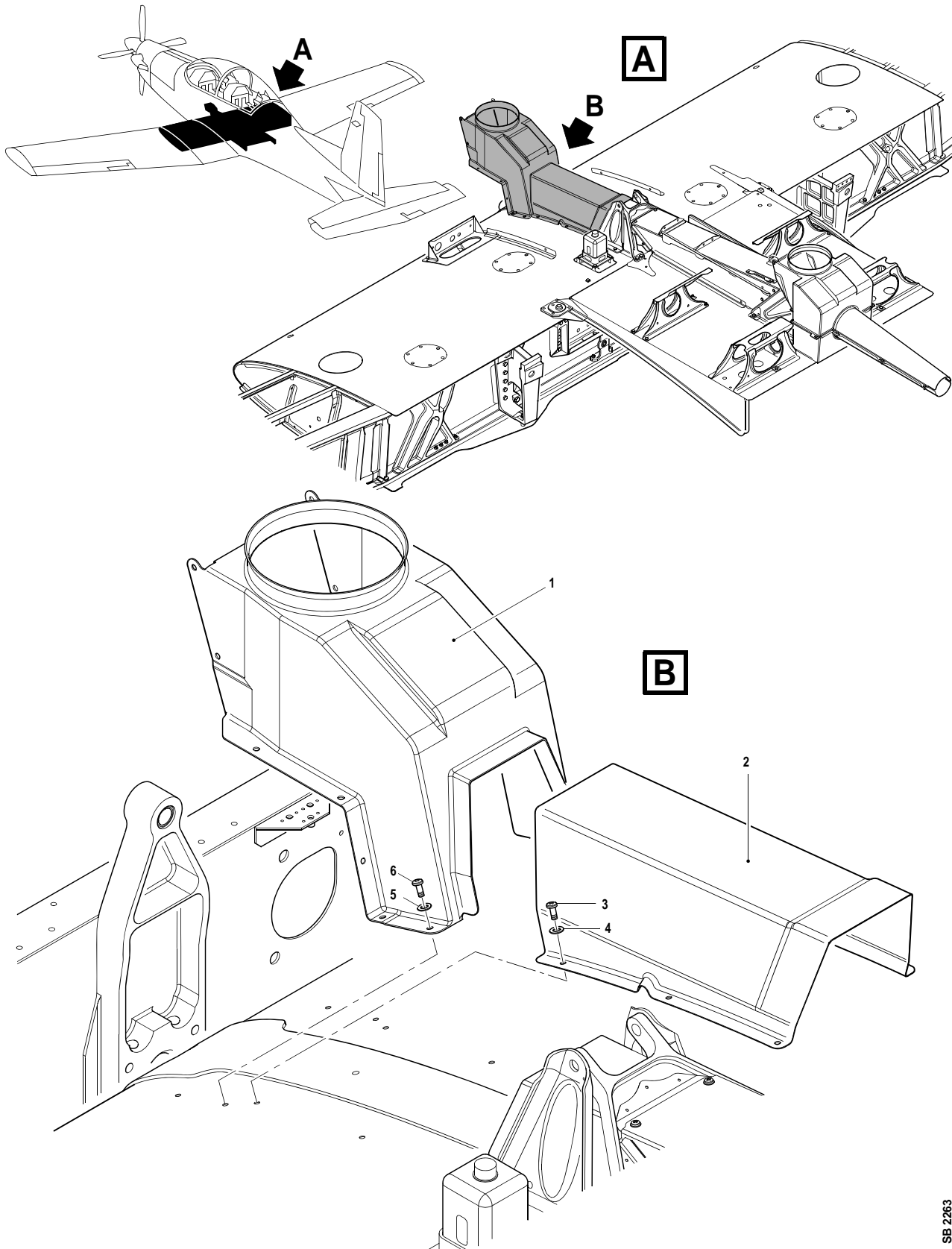

Front-Cockpit Flight Control-Covers - Removal and Installation
Figure 1

SB 2263

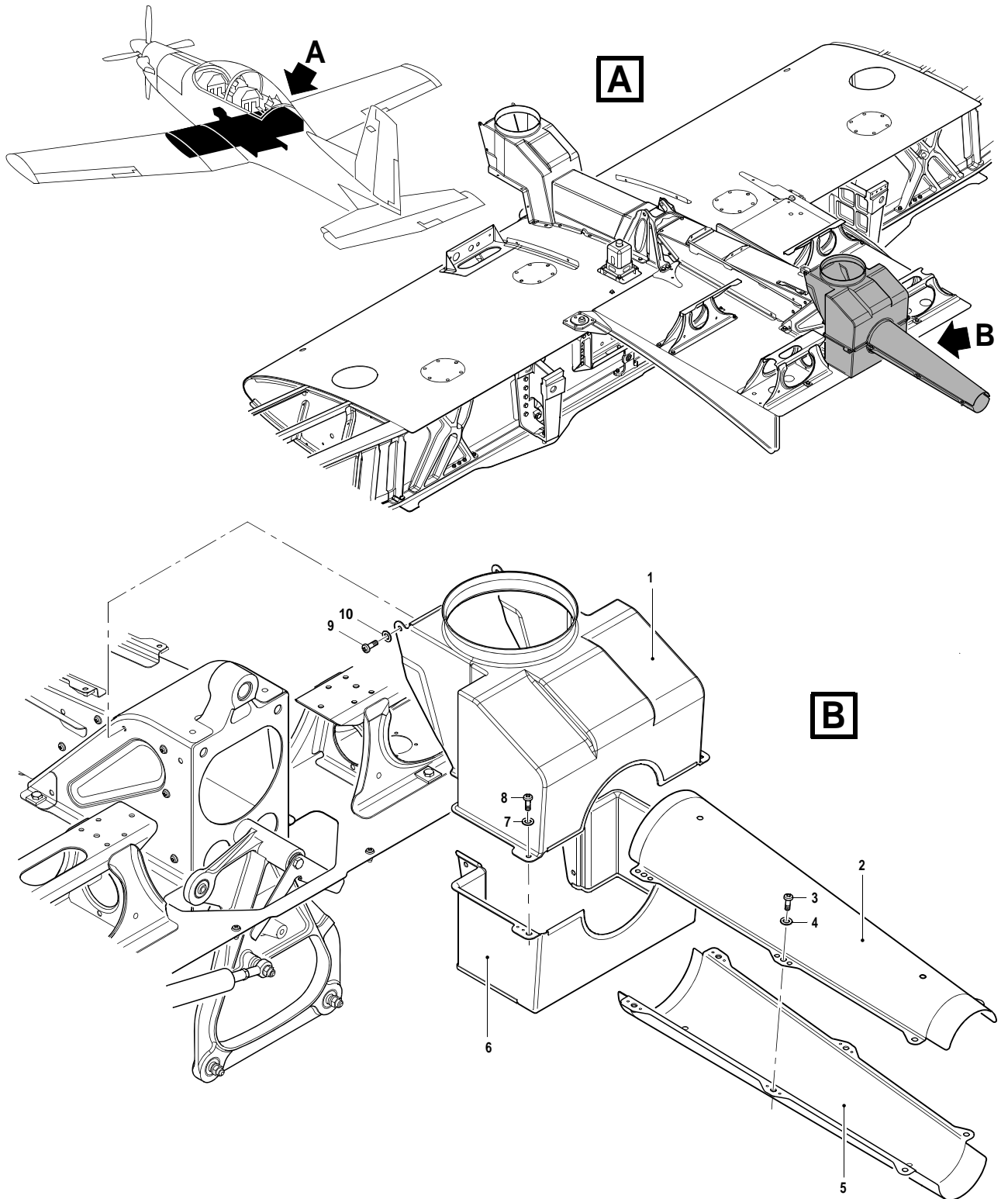

SB 2264

Rear-Cockpit Flight Control-Covers - Removal and Installation
Figure 2

B. Inspection

Obey the manufacturer's operating instructions and calibrate the conductivity measurement equipment.

NOTE: The temperature of the reference plates (P/N 513.57.09.149 and P/N 513.57.09.150) must be approximately the same as the part to be checked.

(1) Inspection of the Aileron Nose Rib 1

NOTE: The left-aileron nose-rib (P/N 557.51.09.013) is part of the left-aileron nose-rib assembly (P/N 557.51.09.101).

NOTE: The right-aileron nose-rib (P/N 557.51.09.014) is part of the right-aileron nose-rib assembly (P/N 557.51.09.102).

NOTE: Only personnel that are qualified and authorized by their designated Airworthiness Authorities are allowed to do this test.

(a) Do the conductivity test to find the material of the left-aileron nose-rib and right-aileron nose-rib (Ref. SRM, 57-51-00).

1 Remove the dirt and grease from the areas (where you will do the test) with the absorbent paper (Material No. P02-031) made moist with the solvent (Material No. P01-010).

NOTE: It is not necessary to remove the layers of surface protection (including paint) to do the test.

2 Do a check of the conductivity of the reference plates:

a Make sure the conductivity measurement equipment has been calibrated (Ref. Step at beginning of Para. 3.B.).

b Put the eddy current probe in position on the reference plates (P/N 513.57.09.149 and P/N 513.57.09.150).

c Record the value shown on the test equipment.

NOTE: Make sure the temperature of the reference plates (P/N 513.57.09.149 and P/N 513.57.09.150) is approximately the same as the left-aileron nose-rib (P/N 557.51.09.013) and the right-aileron nose-rib (P/N 557.51.09.014).

3 Put the eddy current probe in position on the left-aileron nose-rib 1 (P/N 557.51.09.013).

4 Record the value shown on the test equipment.

5 Compare the value recorded above with the values recorded in Step 3.B.(1)(a)2c and determine if the aileron nose-rib 1 is manufactured from AA2024-T351 or AA2124-T851.

6 Do Steps 3.B.(1)(a)3 thru 5 again to make sure the result is the same.

- 7 Write the type of material that the left-aileron nose-rib 1 is made from on the Status of Parts Form (Ref. Fig. 29).
- 8 Do Step 3.B.(1)(a)1 thru 7 again on the right-aileron nose-rib 1 (P/N 557.51.09.014).
- (b) If you find an aileron nose rib made from AA2024-T351, continue this Service Bulletin from Step 3.B.(1)(d).
- (c) If the aileron nose ribs are made from AA2124-T851, re-identify them (Ref. Para. 2.D.) and continue this Service Bulletin from Step 3.B.(2).
- (d) Do an inspection for cracks (Ref. Fig. 3):

NOTE: Step 3.B.(1)(d) is only applicable to aileron nose ribs made from AA2024-T351.

NOTE: Only personnel that are qualified and authorized by their designated Airworthiness Authorities are allowed to do this test.

- 1 Use the absorbent paper (Material No. P02-031) made moist with the solvent (Material No. P01-010) and remove the dirt and grease from the inspection areas of the left-aileron nose-rib 1 assembly (P/N 557.51.09.101).

NOTE: It is not necessary to remove the layers of surface protection to do the inspection.

- 2 Use a bright light source and a mirror to examine the inspection areas of the left-aileron nose-rib 1 for cracks.

- 3 If you find cracks:

- a You must contact Pilatus Customer Support before next flight. The address is:

PILATUS AIRCRAFT LTD.,
Customer Technical Support (MCC),
P.O. Box 992
6371 Stans, Switzerland

Fax: + 41 (0) 41 619 67 73
Email: Techsupport@pilatus-aircraft.com.

- b Make a report of the inspection results, refer to Step 3.B.(1)(f).

- 4 If you do not find cracks, make a report of the inspection results, refer Step 3.B.(1)(e).

- 5 Do Step 3.B.(1)(d)1 thru 4 of this Service Bulletin again on the right-aileron nose-rib 1 (P/N 557.51.09.014).

(e) Report the Inspection Results

- 1 Make a copy of the Inspection Report Form(s) (Ref. Fig. 4).
- 2 Complete the Inspection Report Form:
 - Give the date of the inspection.
 - Give the aircraft details.
 - Show the location(s) and dimensions of the crack(s) found (if applicable).
 - Add any necessary comments.

NOTE: If there are no crack indications, the Inspection Report Form is used to tell Pilatus Aircraft Ltd. the aircraft details.

- 3 Send or fax the completed form(s) to:

Pilatus Aircraft Ltd.
Customer Technical Support (MCC)
P.O.Box 992
6371 Stans, Switzerland

Fax No. + 41 (0) 41 619 67 73.
Email: Techsupport@pilatus-aircraft.com.

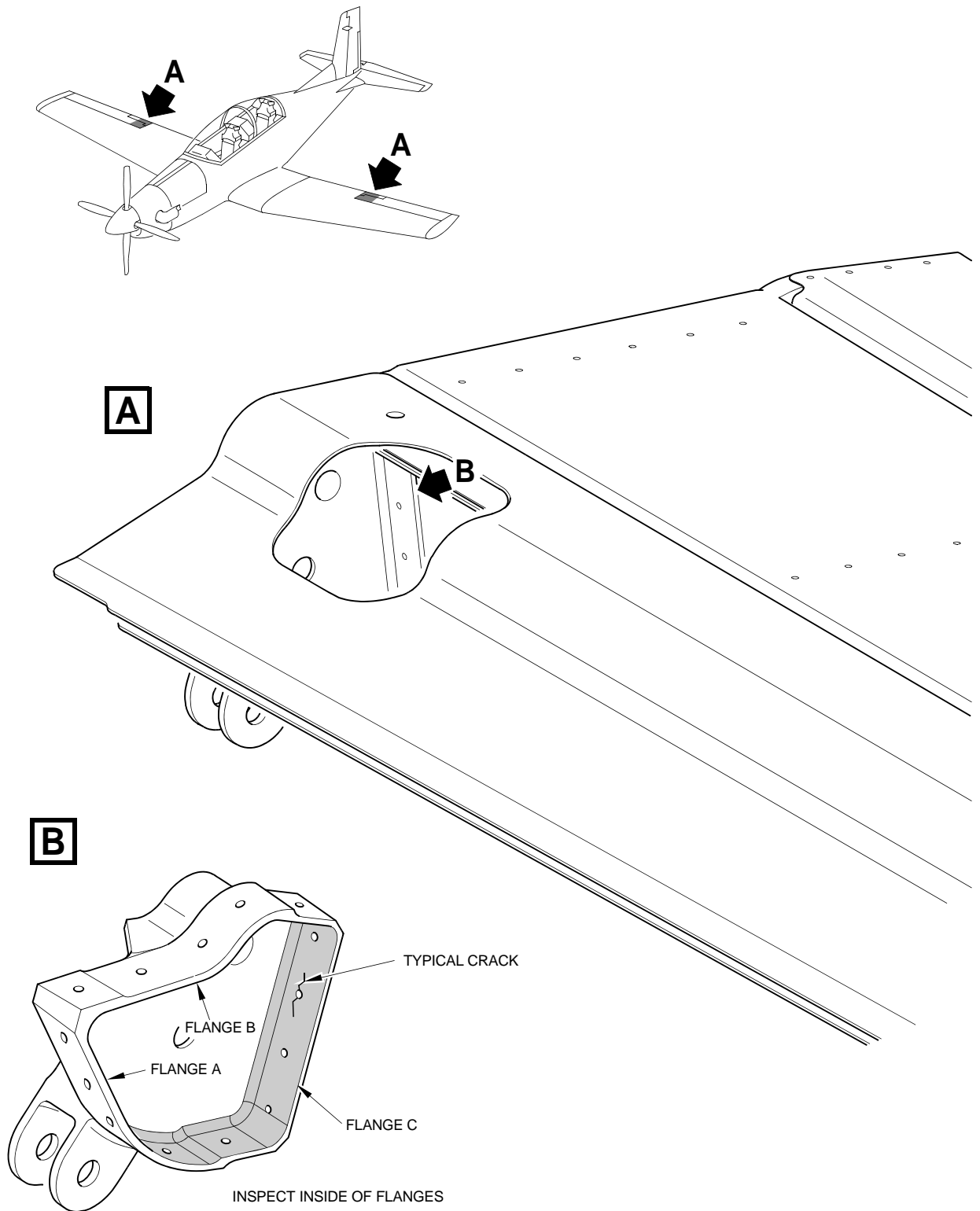

SB 2243

Nose Rib 1 - Inspection (If Necessary)
Figure 3

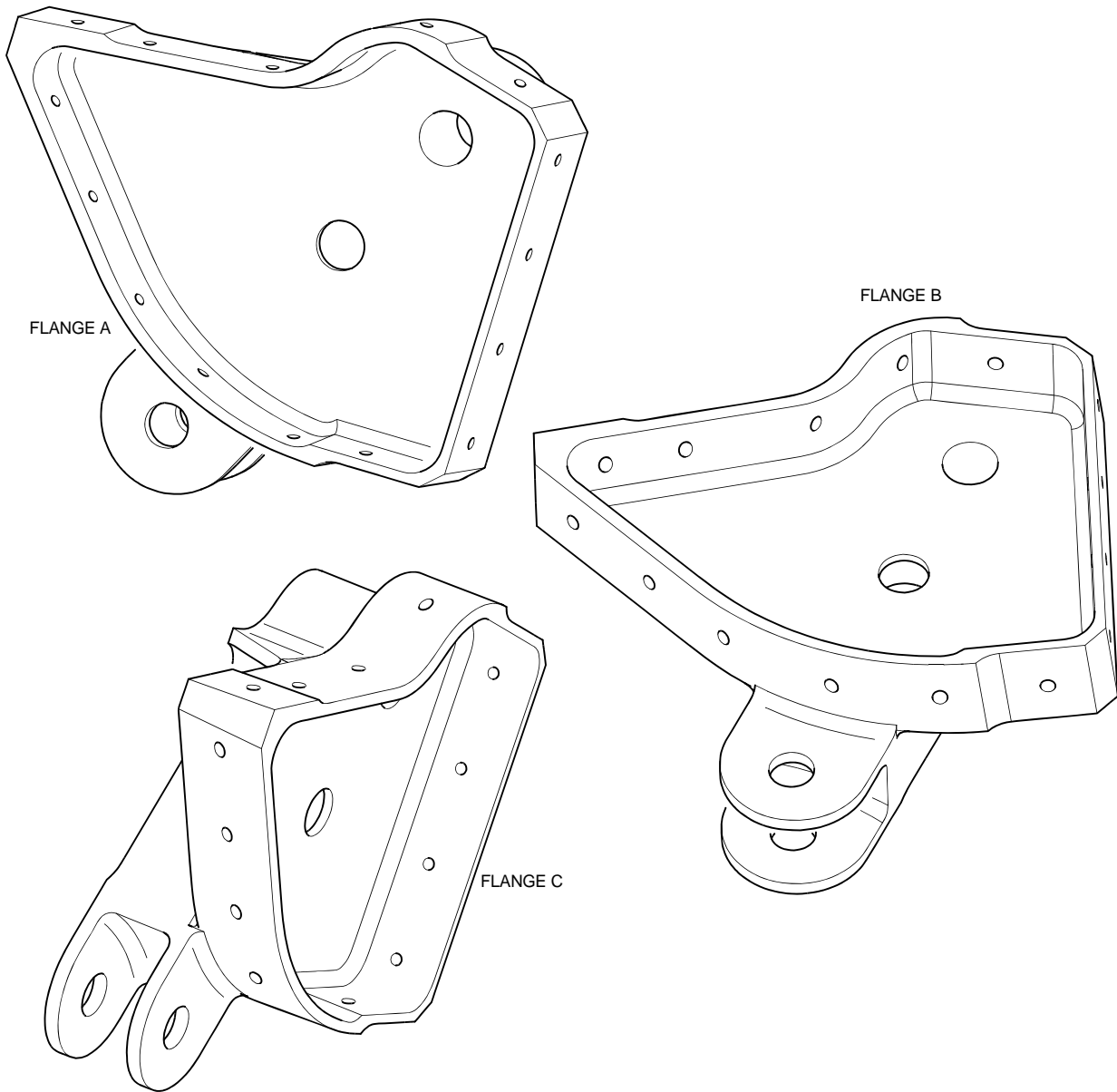

LEFTAILERON NOSE RIB 1

| DATE: | AIRCRAFT MSN: | FLYING HOURS: | LANDINGS: | WING S/N |
|----------------|---------------|---------------------|-----------|----------|
| CRACK 1 LENGTH | mm | ADDITIONAL COMMENTS | | |
| CRACK 2 LENGTH | mm | | | |
| CRACK 3 LENGTH | mm | | | |
| CRACK 4 LENGTH | mm | | | |

SB 2244

Nose Rib 1 - Inspection Form
Figure 4, Sheet 1 of 2

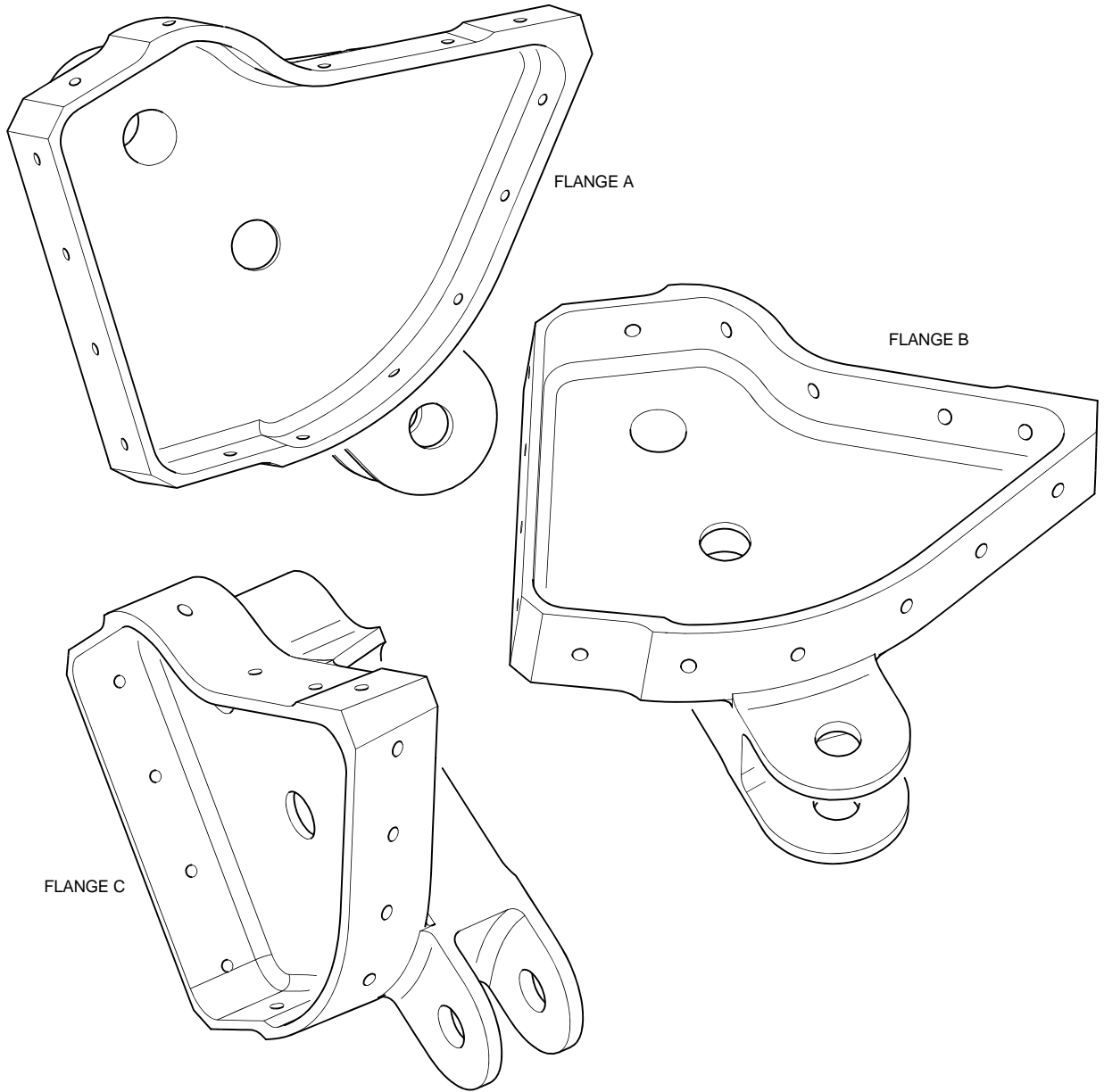

RIGHTAILERON NOSE RIB 1

| DATE: | AIRCRAFT MSN: | FLYING HOURS: | LANDINGS: | WING S/N |
|----------------|---------------|---------------------|-----------|----------|
| CRACK 1 LENGTH | mm | ADDITIONAL COMMENTS | | |
| CRACK 2 LENGTH | mm | | | |
| CRACK 3 LENGTH | mm | | | |
| CRACK 4 LENGTH | mm | | | |

SB 2245

Nose Rib 1 - Inspection Form
Figure 4, Sheet 2 of 2

(2) Inspection of the Elevator Center-Attachment Bearing-Bracket

The elevator center-attachment bearing-bracket can have these part numbers:

- P/N 555.10.09.060 - AA2024-T351
- P/N 555.10.09.143 - AA2124-T851.

NOTE: The elevator center-attachment bearing-bracket (P/N 555.10.09.060) is part of the elevator center-attachment bearing-bracket assembly (P/N 555.10.09.059).

NOTE: The elevator center-attachment bearing-bracket (P/N 555.10.09.143) is part of the elevator center-attachment bearing-bracket assembly (P/N 555.10.09.144).

NOTE: Only personnel that are qualified and authorized by their designated Airworthiness Authorities are allowed to do this test.

- (a) Do the conductivity test to find the material of the elevator center-attachment bearing-bracket (Ref. IPC, 55-10-01).

NOTE: In the IPC, the elevator center-attachment bearing-bracket assembly can also be shown as NPN-55100101A30, NPN-55100101C30, NPN-55100101D30 or NPN-55100101D30.

- 1 Remove the dirt and grease from the areas (where you will do the test) with the absorbent paper (Material No. P02-031) made moist with the solvent (Material No. P01-010).

NOTE: It is not necessary to remove the layers of surface protection (including paint) to do the test.

- 2 Do a check of the conductivity of the reference plates:

a Make sure the conductivity measurement equipment has been calibrated (Ref. Step at beginning of Para. 3.B.).

b Put the eddy current probe in position on the reference plates (P/N 513.57.09.149 and P/N 513.57.09.150).

c Record the value shown on the test equipment.

NOTE: Make sure the temperature of the reference plates (P/N 513.57.09.149 and P/N 513.57.09.150) is approximately the same as the elevator center-attachment bearing-bracket (P/N 555.10.09.060).

- 3 Put the eddy current probe in position on the elevator center-attachment bearing-bracket.

- 4 Record the value shown on the test equipment.

- 5 Compare the value recorded above with the values recorded in Step 3.B.(2)(a)2c and determine if the elevator center-attachment bearing-bracket is manufactured from AA2024-T351 or AA2124-T851.

- 6 Do Steps 3.B.(2)(a)3 thru 5 again to make sure the result is the same.

- 7 Write the type of material that the elevator center-attachment bearing-bracket is made from on the Status of Parts Form (Ref. Fig. 29).
- (b) If you find an elevator center-attachment bearing-bracket made from AA2024-T351, it is P/N 555.10.09.060. Continue this Service Bulletin from Step 3.B.(2)(d).
- (c) If you find an elevator center-attachment bearing-bracket made from AA2124-T851, it is P/N 555.10.09.143. Re-identify it (Ref. Para. 2.D.) and continue this Service Bulletin from Step 3.B.(3).
- (d) Do an eddy-current Non-Destructive-Inspection (NDI) for cracks (Ref. Fig. 5):

NOTE: Step 3.B.(2)(d) is only applicable to elevator center-attachment bearing-brackets made from AA2024-T351.

NOTE: Only personnel that are qualified and authorized by their designated Airworthiness Authorities are allowed to do this test.

- 1 Remove the elevator assembly (Ref. 27-30-01, Page Block 401).
- 2 From hole 4, remove the nut (4), the washer (3), the bolt (1) and the washer (2).
- 3 Use the absorbent paper (Material No. P02-031) made moist with the solvent (Material No. P01-010) and remove the dirt and grease from the inspection areas of the elevator center-attachment bearing-bracket.
- NOTE:** It is not necessary to remove the layers of surface protection to do the inspection.
- 4 Obey the manufacturer's instructions and calibrate the eddy-current NDI equipment.
- 5 Obey the manufacturer's instructions and move the probe of the eddy-current NDI equipment over the inspection areas shown in Fig. 5.
- 6 Apply a layer of the corrosion preventative (Material No. P04-039) to the shank of the bolt (1).
- 7 Install the bolt (1), the washer (2), the washer (3) and the nut (4).
- 8 Do Steps 3.B (2)(d)2 thru 7 again for the other 3 holes.
- 9 If you find cracks:

- a You must contact Pilatus Customer Support before next flight. The address is:

PILATUS AIRCRAFT LTD.,
Customer Technical Support (MCC),
P.O. Box 992
6371 Stans, Switzerland

Fax: + 41 (0) 41 619 67 73
Email: Techsupport@pilatus-aircraft.com.

- b Make a report of the inspection results, refer to Step 3.B.(2)(e).
- 10 If you do not find cracks, make a report of the inspection results, refer to Step 3.B.(2)(e).
- 11 Install the elevator assembly (Ref. 27-30-01, Page Block 401).
- (e) Reporting of Inspection Results (Ref. Fig. 6)
- 1 Make a copy of the Inspection Report Form (Ref. Fig. 6).
- 2 Complete the Inspection Report Form:
- Give the date of the inspection.
 - Give the aircraft details.
 - Show the location(s) and dimensions of the crack(s) found (if applicable).
 - Add any necessary comments.

NOTE: If there no crack indications, the Inspection Report Form is used to tell Pilatus Aircraft Ltd. the aircraft details.

- 3 Send or fax the completed form(s) to:

Pilatus Aircraft Ltd.
Customer Technical Support (MCC)
P.O.Box 992
6371 Stans, Switzerland

Fax No. + 41 (0) 41 619 67 73.
Email: Techsupport@pilatus-aircraft.com.

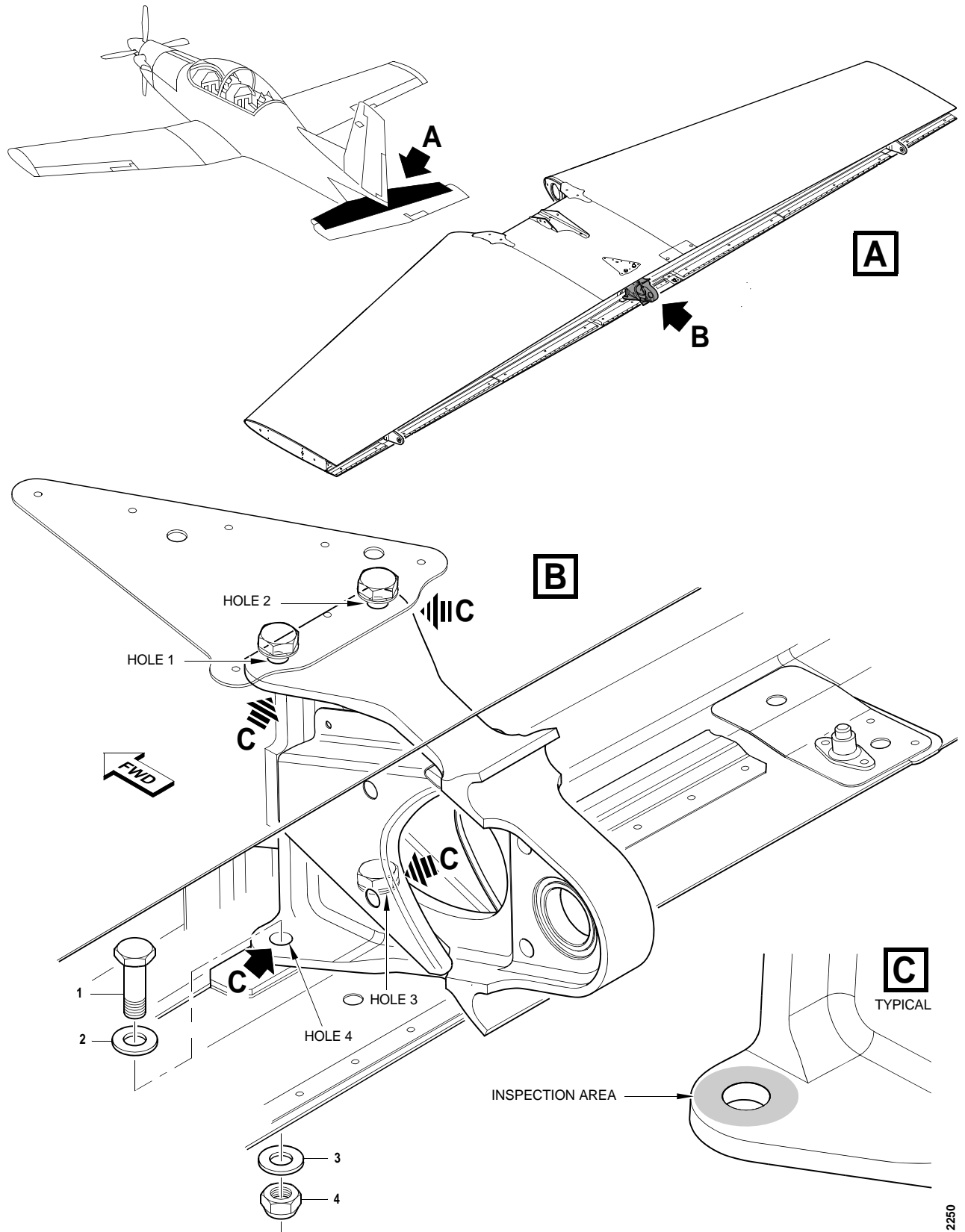

Elevator Center-Attachment Bearing-Bracket - Inspection (If Necessary)
Figure 5

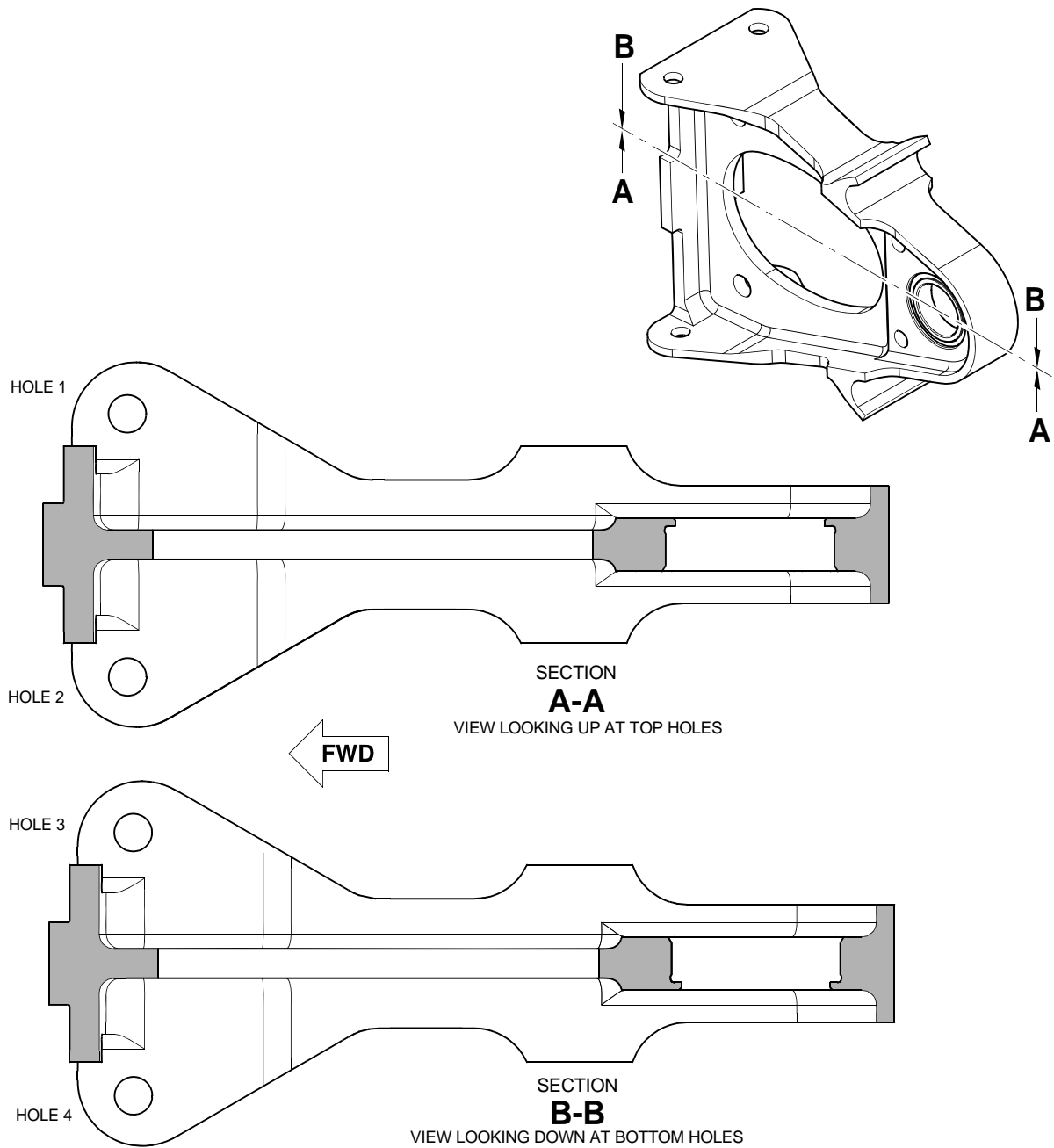

| | | | |
|--------------------------------|---------------------|---------------|-----------|
| DATE: | AIRCRAFT MSN: | FLYING HOURS: | LANDINGS: |
| HOLE 1 CRACK LENGTH mm | ADDITIONAL COMMENTS | | |
| HOLE 2 CRACK LENGTH mm | | | |
| HOLE 3 CRACK LENGTH mm | | | |
| HOLE 4 CRACK LENGTH mm | | | |

SB 2251

Elevator Center-Attachment Bearing-Bracket - Inspection Form
Figure 6

(3) Inspection of the Rudder Lower-Hinge Bearing-Bracket

NOTE: The rudder lower-hinge bearing-bracket (P/N 555.30.09.039) is part of the rudder lower-hinge bearing-bracket assembly (P/N 555.30.09.040).

NOTE: Only personnel that are qualified and authorized by their designated Airworthiness Authorities are allowed to do this test.

- (a) Do the conductivity test to find the material of the rudder lower-hinge bearing-bracket (Ref. IPC, 55-30-01).

NOTE: In the IPC, the rudder lower-hinge bearing-bracket assembly can be shown as NPN-55300101A10, NPN-55300101C10, NPN-55300101D10 or NPN-55300101V10.

- 1 Remove the dirt and grease from the areas (where you will do the test) with the absorbent paper (Material No. P02-031) made moist with the solvent (Material No. P01-010).

NOTE: It is not necessary to remove the layers of surface protection (including paint) to do the test.

- 2 Do a check of the conductivity of the reference plates:

a Make sure the conductivity measurement equipment has been calibrated (Ref. Step at beginning of Para. 3.B.).

b Put the eddy current probe in position on the reference plates (P/N 513.57.09.149 and P/N 513.57.09.150).

c Record the value shown on the test equipment.

NOTE: Make sure the temperature of the reference plates (P/N 513.57.09.149 and P/N 513.57.09.150) is approximately the same as the rudder lower-hinge bearing-bracket (P/N 555.30.09.039).

- 3 Put the eddy current probe in position on the rudder lower-hinge bearing-bracket.

- 4 Record the value shown on the test equipment.

- 5 Compare the value recorded above with the values recorded in Step 3.B.(3)(a)2c and determine if the rudder lower-hinge bearing-bracket is manufactured from AA2024-T351 or AA2124-T851.

- 6 Do Steps 3.B.(3)(a)3 thru 5 again to make sure the result is the same.

- 7 Write the type of material that the rudder lower-hinge bearing-bracket is made from on the Status of Parts Form (Ref. Fig. 29).

- (b) If you find a rudder lower-hinge bearing-bracket made from AA2024-T351, continue this Service Bulletin from Step 3.B.(3)(d).

- (c) If you find a rudder lower-hinge bearing-bracket made from AA2124-T851, re-identify it (Ref. Para. 2.D.) and continue this Service Bulletin from Step 3.B.(4).

- (d) Do an eddy-current Non-Destructive-Inspection (NDI) for cracks (Ref. Fig. 7):

NOTE: Step 3.B.(3)(d) is only applicable to rudder lower-hinge bearing-brackets made from AA2024-T351.

NOTE: Only personnel that are qualified and authorized by their designated Airworthiness Authorities are allowed to do this test.

- 1 Remove the rudder assembly (Ref. 27-20-01, Page Block 401).

CAUTION: DO NOT PUT LOADS ON THE RUDDER LOWER-HINGE-BRACKET (4) WHEN THE BOLTS (1) ARE REMOVED. THIS COULD CAUSE THE RUDDER LOWER-HINGE-BRACKET (4) TO MOVE SLIGHTLY.

- 2 Remove the nuts (3), the washers (2) and the bolts (1) from the four attachment bolt holes of the rudder lower-hinge-bracket (4).

- 3 Use the absorbent paper (Material No. P02-031) made moist with the solvent (Material No. P01-010) and remove the dirt and grease from the inspection areas of the rudder lower-hinge bearing-bracket.

NOTE: It is not necessary to remove the layers of surface protection to do the inspection.

- 4 Obey the manufacturer's instructions and calibrate the eddy-current NDI equipment.

- 5 Obey the manufacturer's instructions and move the probe of the eddy-current NDI equipment over the inspection areas shown in Fig. 7:

- 6 Apply a layer of the corrosion preventative (Material No. P04-039) to the shank of the bolts (1).

- 7 Install the bolts (1), the washers (2) and nuts (3) in the four attachment bolt holes of the rudder lower-hinge-bracket (4).

- 8 If you find cracks:

- a You must contact Pilatus Customer Support before next flight. The address is:

PILATUS AIRCRAFT LTD.,
Customer Technical Support (MCC),
P.O. Box 992
6371 Stans, Switzerland

Fax: + 41 (0) 41 619 67 73
Email: Techsupport@pilatus-aircraft.com.

- b Make a report of the inspection results, refer to Step 3.B.(3)(e).

- 9 If you do not find cracks, make a report of the inspection results, refer to Step 3.B.(3)(e).

- 10 Install the rudder assembly (Ref. 27-20-01, Page Block 401).

(e) Reporting of Inspection Results (Ref. Fig. 8)

- 1 Make a copy of the Inspection Report Form (Ref. Fig. 8).
- 2 Complete the Inspection Report Form:
 - Give the date of the inspection.
 - Give the aircraft details.
 - Show the location(s) and dimensions of the crack(s) found (if applicable).
 - Add any necessary comments.

NOTE: If there no crack indications, the Inspection Report Form is used to tell Pilatus Aircraft Ltd. the aircraft details.

- 3 Send or fax the completed form(s) to:

Pilatus Aircraft Ltd.
Customer Technical Support (MCC)
P.O.Box 992
6371 Stans, Switzerland

Fax No. + 41 (0) 41 619 67 73.
Email: Techsupport@pilatus-aircraft.com.

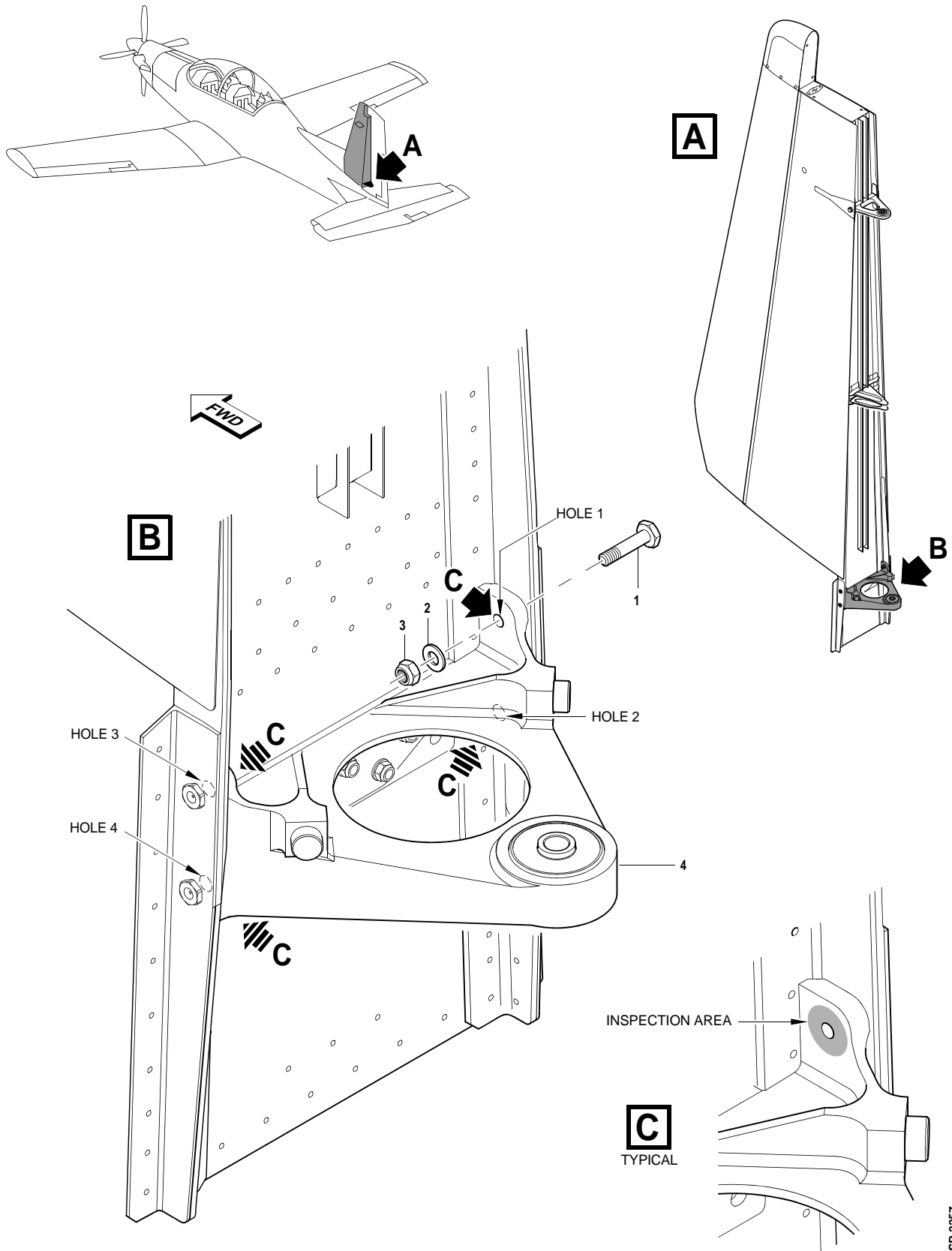

Lower Rudder Bracket - Inspection (If Necessary)
Figure 7

SB 2257

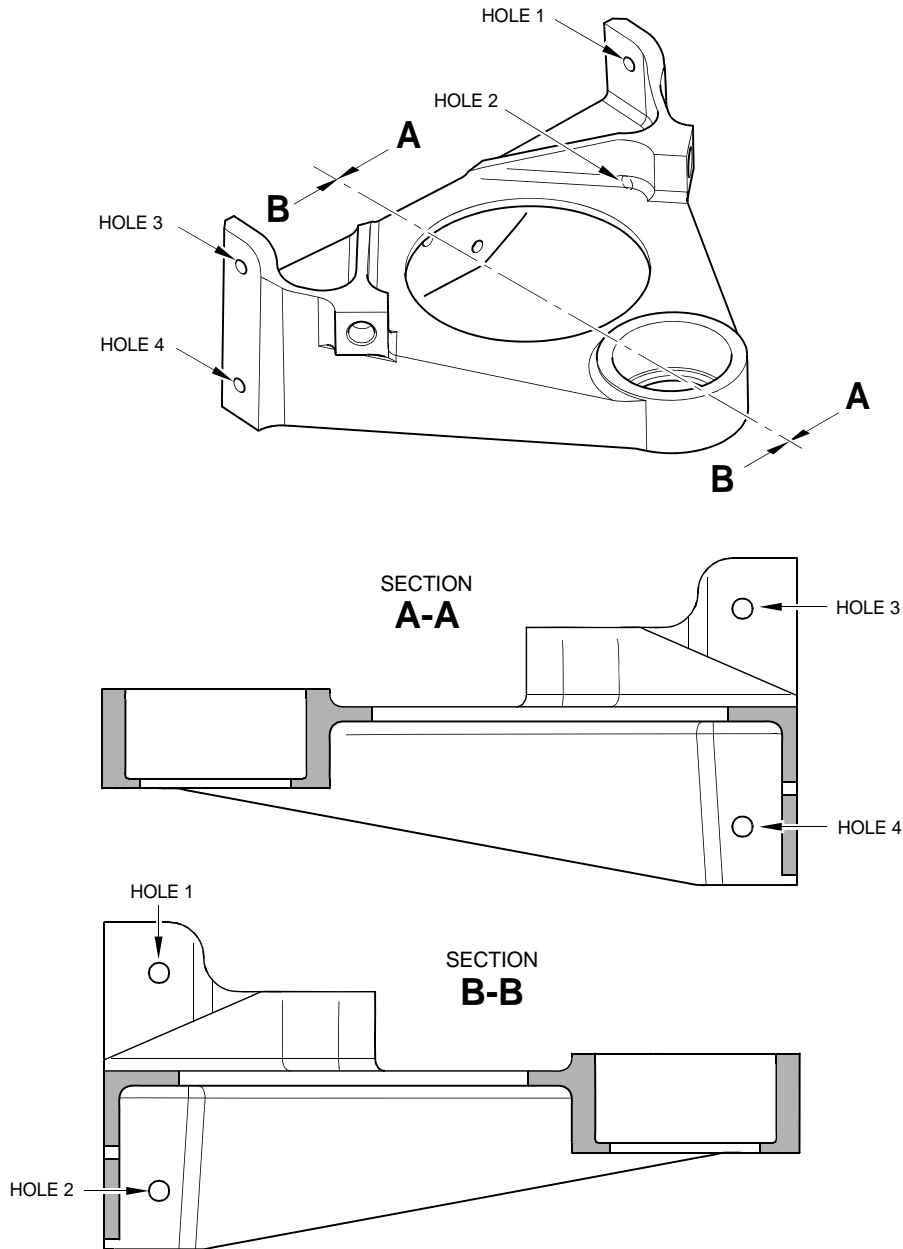

| DATE: | AIRCRAFT MSN: | FLYING HOURS: | LANDINGS: |
|------------------------|---------------------|---------------|-----------|
| HOLE 1 CRACK LENGTH | ADDITIONAL COMMENTS | | |
| mm | | | |
| HOLE 2 CRACK LENGTH | | | |
| mm | | | |
| HOLE 3 CRACK LENGTH | | | |
| mm | | | |
| HOLE 4 CRACK LENGTH | | | |
| mm | | | |

SB 2258

Lower Rudder Bracket - Inspection Form
Figure 8

(4) Inspection of Frame 3 Pick-Up Bracket

NOTE: Only personnel that are qualified and authorized by their designated Airworthiness Authorities are allowed to do this test.

(a) Do the conductivity test to find the material of the left frame 3 pick-up bracket (P/N 553.10.09.075) and right frame 3 pick-up bracket (P/N 553.10.09.076) (Ref. SRM, 53-10-02).

1 Remove the dirt and grease from the areas (where you will do the test) with the absorbent paper (Material No. P02-031) made moist with the solvent (Material No. P01-010).

NOTE: It is not necessary to remove the layers of surface protection (including paint) to do the test.

2 Do a check of the conductivity of the reference plates:

a Make sure the conductivity measurement equipment has been calibrated (Ref. Step at beginning of Para. 3.B.).

b Put the eddy current probe in position on the reference plates (P/N 513.57.09.149 and P/N 513.57.09.150).

c Record the value shown on the test equipment.

NOTE: Make sure the temperature of the reference plates (P/N 513.57.09.149 and P/N 513.57.09.150) is approximately the same as the left frame 3 pick-up bracket (P/N 553.10.09.075) and right frame 3 pick-up bracket (P/N 553.10.09.076).

3 Put the eddy current probe in position on the left frame 3 pick-up bracket.

4 Record the value shown on the test equipment.

5 Compare the value recorded above with the values recorded in Step 3.B.(4)(a)2c and determine if the frame 3 pick-up bracket is manufactured from AA2024-T351 or AA2124-T851.

6 Do Steps 3.B.(4)(a)3 thru 5 again to make sure the result is the same.

7 Write the type of material that the left frame 3 pick-up bracket is made from on the Status of Parts Form (Ref. Fig. 29).

(b) Do Step 3.B.(4)(a)1 thru 7 again on the right frame 3 pick-up bracket.

(c) If you find a frame 3 pick-up bracket made from AA2024-T351, continue this Service Bulletin from Step 3.B.(4)(e).

(d) If the frame 3 pick-up brackets are made from AA2124-T851, re-identify them (Ref. Para. 2.D.) and continue this Service Bulletin from Step 3.B.(5).

(e) Do an inspection for cracks (Ref. Fig. 9):

NOTE: Step 3.B.(4)(e) is only applicable to frame 3 pick-up brackets made from AA2024-T351.

NOTE: Only personnel that are qualified and authorized by their designated Airworthiness Authorities are allowed to do this test.

1 Use the absorbent paper (Material No. P02-031) made moist with the solvent (Material No. P01-010) and remove the dirt and grease from the inspection areas of the left frame 3 pick-up bracket.

NOTE: It is not necessary to remove the layers of surface protection to do the inspection.

2 Obey the manufacturer's instructions and use a boroscope to examine the inspection areas of the left frame 3 pick-up bracket for cracks.

3 If you find cracks:

a You must contact Pilatus Customer Support before next flight. The address is:

PILATUS AIRCRAFT LTD.,
Customer Technical Support (MCC),
P.O. Box 992
6371 Stans, Switzerland

Fax: + 41 (0) 41 619 67 73
Email: Techsupport@pilatus-aircraft.com.

b Make a report of the inspection results, refer to Step 3.B(4)(f).

4 If you do not find cracks, make a report of the inspection results, refer Step 3.B.(4)(f).

5 Do Step 3.B.(4)(e)1 thru 4 again on the right frame 3 pick-up bracket.

(f) Report the Inspection Results

1 Make a copy of the Inspection Report Form(s) (Ref. Fig. 10).

2 Complete the Inspection Report Form:

- Give the date of the inspection.
- Give the aircraft details.
- Show the location(s) and dimensions of the crack(s) found (if applicable).
- Add any necessary comments.

NOTE: If there are no crack indications, the Inspection Report Form is used to tell Pilatus Aircraft Ltd. the aircraft details.

3 Send or fax the completed form(s) to:

Pilatus Aircraft Ltd.
Customer Technical Support (MCC)
P.O.Box 992
6371 Stans, Switzerland

Fax No. + 41 (0) 41 619 67 73.
Email: Techsupport@pilatus-aircraft.com.

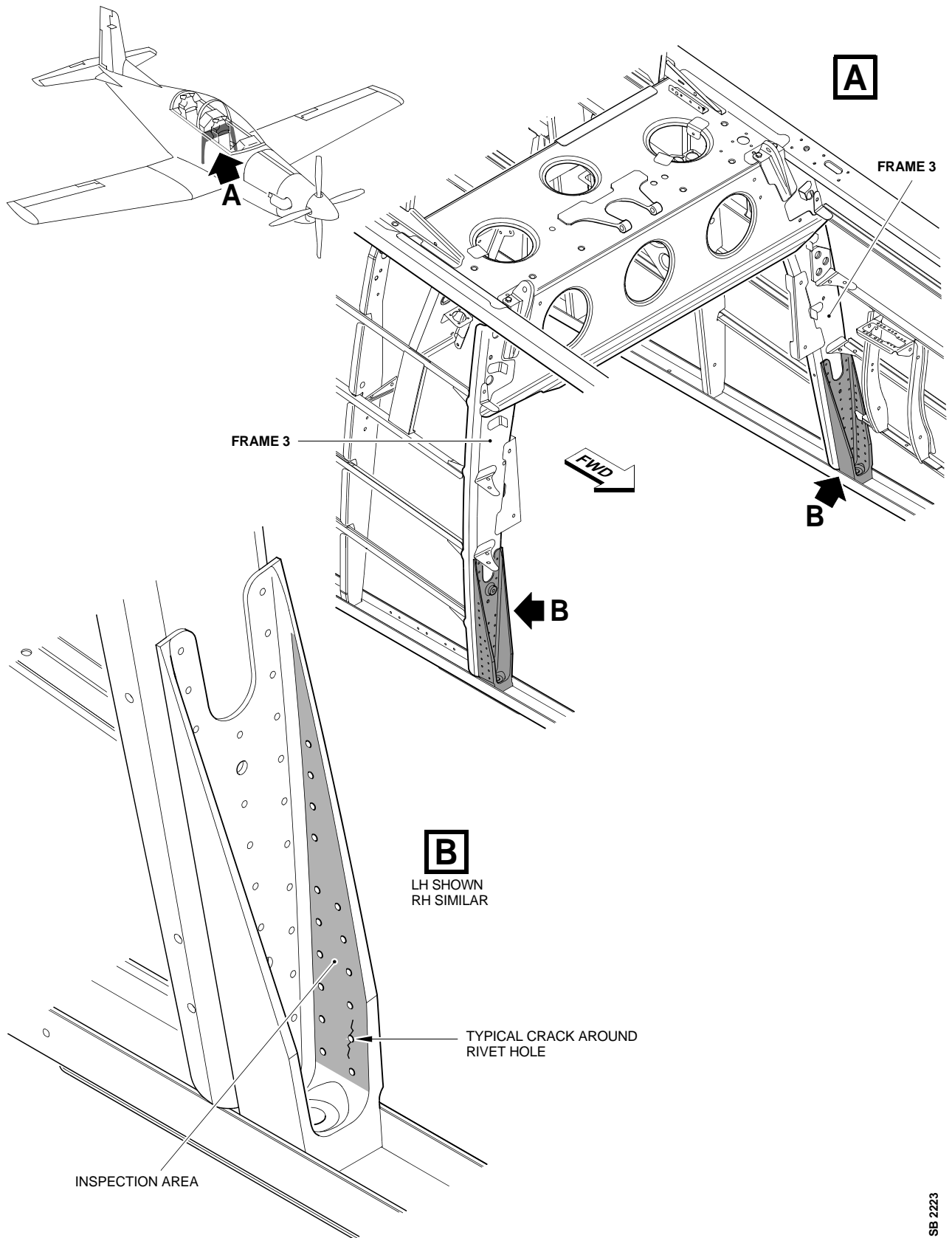

Frame 3 Pick-Up Brackets - Inspection (If Necessary)
Figure 9

LH PICK UP BRACKET

| | | | | | | | |
|----------------|----|---------------------|--|---------------|--|-----------|--|
| DATE: | | AIRCRAFT MSN: | | FLYING HOURS: | | LANDINGS: | |
| CRACK 1 LENGTH | mm | ADDITIONAL COMMENTS | | | | | |
| CRACK 2 LENGTH | mm | | | | | | |
| CRACK 3 LENGTH | mm | | | | | | |
| CRACK 4 LENGTH | mm | | | | | | |

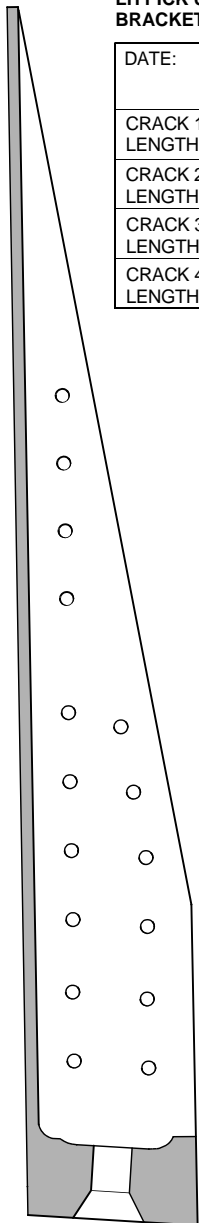

RH PICK UP BRACKET

| | | | | | | | |
|----------------|----|---------------------|--|---------------|--|-----------|--|
| DATE: | | AIRCRAFT MSN: | | FLYING HOURS: | | LANDINGS: | |
| CRACK 1 LENGTH | mm | ADDITIONAL COMMENTS | | | | | |
| CRACK 2 LENGTH | mm | | | | | | |
| CRACK 3 LENGTH | mm | | | | | | |
| CRACK 4 LENGTH | mm | | | | | | |

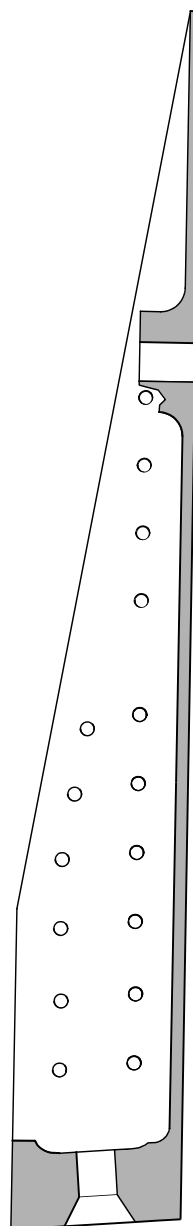

SB 2226

Frame 3 Pick-Up Brackets - Inspection Form
Figure 10

(5) Inspection of the Left and Right Flap Bearing Support-Bracket

NOTE: Only personnel that are qualified and authorized by their designated Airworthiness Authorities are allowed to do this test.

- (a) Do the conductivity test to find the material of the left flap bearing support-bracket (P/N 111.34.07.329) and the right flap bearing support-bracket (P/N 111.34.07.330) (Ref. Fig. 11).

- 1 Remove the dirt and grease from the areas (where you will do the test) with the absorbent paper (Material No. P02-031) made moist with the solvent (Material No. P01-010).

NOTE: It is not necessary to remove the layers of surface protection (including paint) to do the test.

- 2 Do a check of the conductivity of the reference plates:

a Make sure the conductivity measurement equipment has been calibrated (Ref. Step at beginning of Para. 3.B.).

b Put the eddy current probe in position on the reference plates (P/N 513.57.09.149 and P/N 513.57.09.150).

c Record the value shown on the test equipment.

NOTE: Make sure the temperature of the reference plates (P/N 513.57.09.149 and P/N 513.57.09.150) is approximately the same as the left flap bearing support-bracket (P/N 111.34.07.329) and the right flap bearing support-bracket (P/N 111.34.07.330).

- 3 Put the eddy current probe in position on the left flap bearing support-bracket.

- 4 Record the value shown on the test equipment.

- 5 Compare the value recorded above with the values recorded in 3.B.(5)(a)2c and determine if the flap bearing support-bracket is manufactured from AA2024-T351 or AA2124-T851.

- 6 Do Steps 3.B.(5)(a)3 thru 5 again to make sure the result is the same.

- 7 Write the type of material that the left flap bearing support-bracket is made from on the Status of Parts Form (Ref. Fig. 29).

- 8 Do Step 3.B.(5)(a)1 thru 7 again on the right flap bearing support-bracket.

- (b) If you find a flap bearing support-bracket made from AA2024-T351, continue this Service Bulletin from Step 3.B.(5)(d).

- (c) If you find a flap bearing support-bracket made from AA2124-T851, re-identify them (Ref. Para. 2.D.) and continue this Service Bulletin from Step 3.B.(6).

(d) Do an inspection for cracks (Ref. Fig. 11):

NOTE: Step 3.B.(5)(d) is only applicable to flap bearing support-brackets made from AA2024-T351.

NOTE: Only personnel that are qualified and authorized by their designated Airworthiness Authorities are allowed to do this test.

1 Use the absorbent paper (Material No. P02-031) made moist with the solvent (Material No. P01-010) and remove the dirt and grease from the inspection areas of the left flap bearing support-bracket.

NOTE: It is not necessary to remove the layers of surface protection to do the inspection.

2 Obey the manufacturer's instructions and use a boroscope to examine the inspection areas of the left flap bearing support-bracket for cracks.

3 If you find cracks:

a You must contact Pilatus Customer Support before next flight. The address is:

PILATUS AIRCRAFT LTD.,
Customer Technical Support (MCC),
P.O. Box 992
6371 Stans, Switzerland

Fax: + 41 (0) 41 619 67 73
Email: Techsupport@pilatus-aircraft.com.

b Make a report of the inspection results, refer to Step 3.B.(5)(e).

4 If you do not find cracks, make a report of the inspection results, refer Step 3.B.(5)(e).

5 Do Step 3.B.(5)(d)1 thru 4 again on the right flap bearing support-bracket.

(e) Report the Inspection Results

1 Make a copy of the Inspection Report Form(s) (Ref. Fig. 12).

2 Complete the Inspection Report Form:

- Give the date of the inspection.
- Give the aircraft details.
- Show the location(s) and dimensions of the crack(s) found (if applicable).
- Add any necessary comments.

NOTE: If there are no crack indications, the Inspection Report Form is used to tell Pilatus Aircraft Ltd. the aircraft details.

3 Send or fax the completed form(s) to:

Pilatus Aircraft Ltd.
Customer Technical Support (MCC)
P.O.Box 992
6371 Stans, Switzerland

Fax No. + 41 (0) 41 619 67 73.
Email: Techsupport@pilatus-aircraft.com.

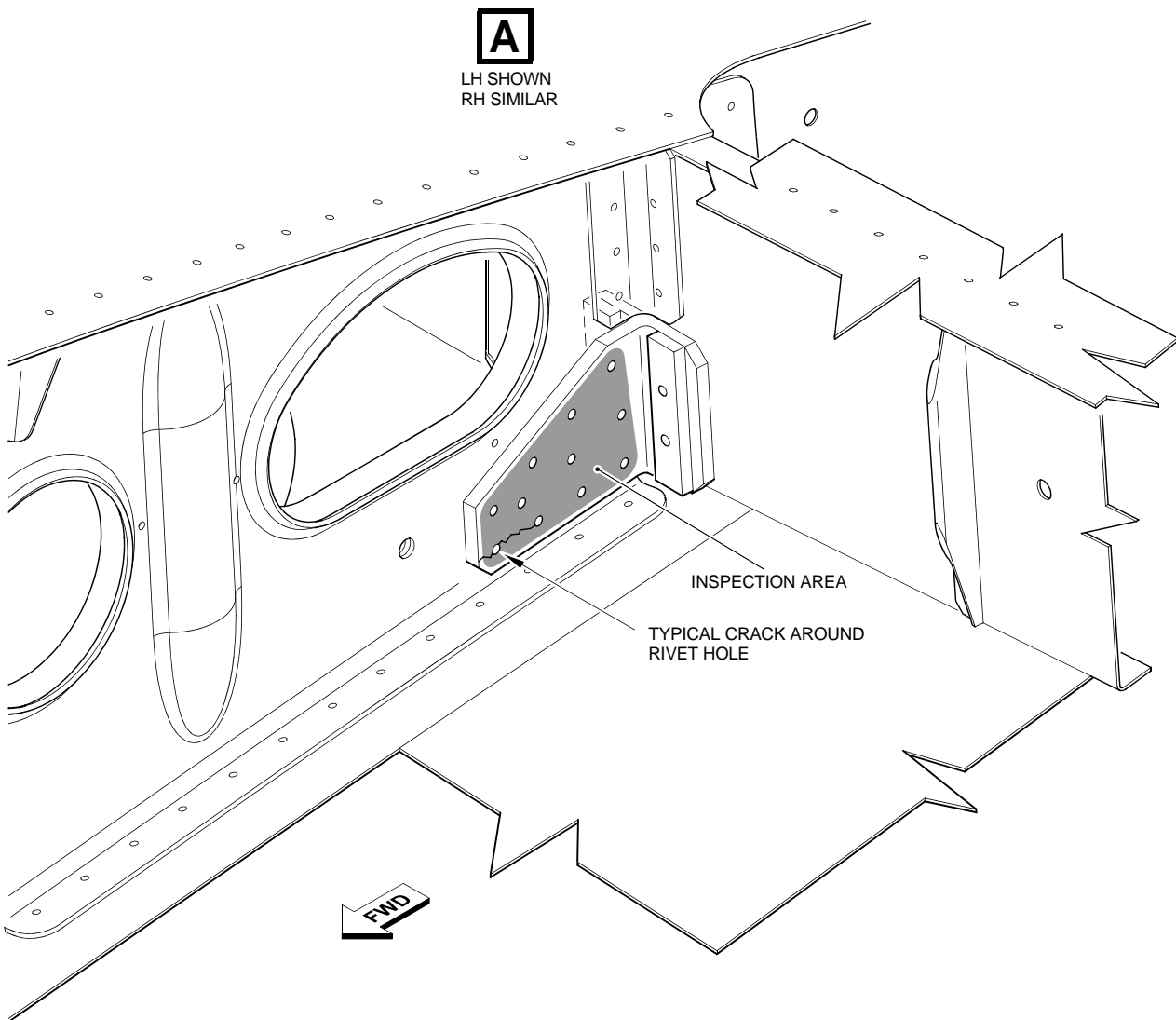
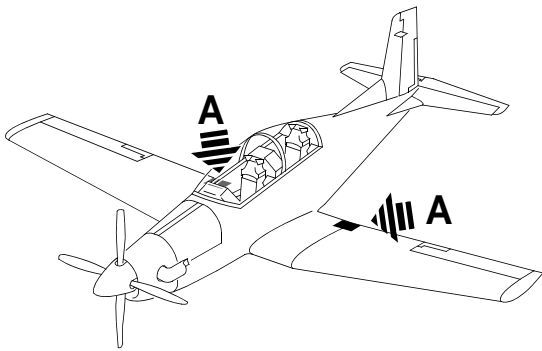

SB 2265

Left and Right Flap Bearing Support-Bracket - Inspection (If Necessary)
Figure 11

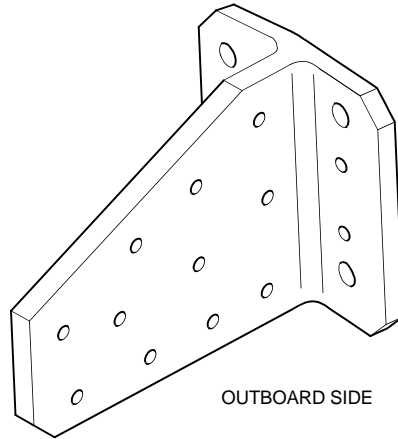

OUTBOARD SIDE

LEFT FLAP SUPPORT BRACKET

| DATE: | AIRCRAFT MSN: | FLYING HOURS: | LANDINGS: | WING S/N |
|----------------|---------------|---------------------|-----------|----------|
| CRACK 1 LENGTH | mm | ADDITIONAL COMMENTS | | |
| CRACK 2 LENGTH | mm | | | |
| CRACK 3 LENGTH | mm | | | |
| CRACK 4 LENGTH | mm | | | |

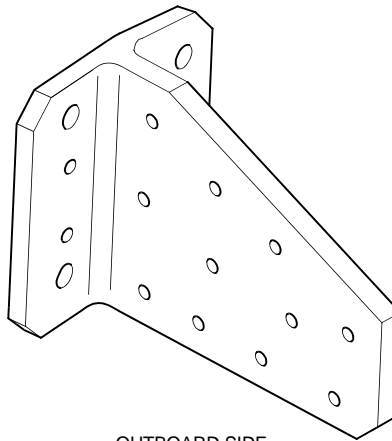

OUTBOARD SIDE

RIGHT FLAP SUPPORT BRACKET

| DATE: | AIRCRAFT MSN: | FLYING HOURS: | LANDINGS: | WING S/N |
|----------------|---------------|---------------------|-----------|----------|
| CRACK 1 LENGTH | mm | ADDITIONAL COMMENTS | | |
| CRACK 2 LENGTH | mm | | | |
| CRACK 3 LENGTH | mm | | | |
| CRACK 4 LENGTH | mm | | | |

SB 2266

Left and Right Flap Bearing Support-Bracket - Inspection Form
Figure 12

(6) Inspection of the Rear Control-Column Support-Bearing Bracket

The rear control-column support-bearing bracket can have these part numbers:

- P/N 557.31.09.142 - AA2024-T351 or AA2124-T851
- P/N 555.10.09.353 - AA2124-T851.

NOTE: The rear control-column support-bearing bracket (P/N 557.31.09.142) is part of the rear control-column support-bearing bracket assembly (P/N 557.31.09.141).

NOTE: Only personnel that are qualified and authorized by their designated Airworthiness Authorities are allowed to do this test.

(a) Do the conductivity test to find the material of the rear control-column support-bearing bracket (Ref. SRM, 57-31-00).

1 Remove the dirt and grease from the areas (where you will do the test) with the absorbent paper (Material No. P02-031) made moist with the solvent (Material No. P01-010).

NOTE: It is not necessary to remove the layers of surface protection (including paint) to do the test.

2 Do a check of the conductivity of the reference plates:

a Make sure the conductivity measurement equipment has been calibrated (Ref. Step at beginning of Para. 3.B.).

b Put the eddy current probe in position on the reference plates (P/N 513.57.09.149 and P/N 513.57.09.150).

c Record the value shown on the test equipment.

NOTE: Make sure the temperature of the reference plates (P/N 513.57.09.149 and P/N 513.57.09.150) is approximately the same as the rear control-column support-bearing bracket (P/N 557.31.09.142).

3 Put the eddy current probe in position on the rear control-column support-bearing bracket.

4 Record the value shown on the test equipment.

5 Compare the value recorded above with the values recorded in 3.B.(6)(a)2c and determine if the rear control-column support-bearing bracket is manufactured from AA2024-T351 or AA2124-T851.

6 Do Steps 3.B.(6)(a)3 thru 5 again to make sure the result is the same.

7 Write the type of material that the rear control-column support-bearing bracket (P/N 557.31.09.142) is made from on the Status of Parts Form (Ref. Fig. 29).

(b) If you find a rear control-column support-bearing bracket made from AA2024-T351, continue this Service Bulletin from Step 3.B.(6)(d).

(c) If you find a rear control-column support-bearing bracket made from AA2124-T851, re-identify it (Ref. Para. 2.D.) and continue this Service Bulletin from Step 3.B.(7).

(d) Do an Inspection for cracks (Ref. Fig. 13):

NOTE: Step 3.B.(6)(d) is only applicable to rear control-column support-bearing bracket made from AA2024-T351.

NOTE: Examine Area D (the cherrymax rivets) through the two small holes in the upper left and right corners of the rear control-column support-bearing bracket. Examine Area E (the remaining rivets) through the larger center hole.

NOTE: Only personnel that are qualified and authorized by their designated Airworthiness Authorities are allowed to do this test.

1 If necessary, use the absorbent paper (Material No. P02-031) made moist with the solvent (Material No. P01-010) and remove the dirt and grease from the inspection areas of the rear control-column support-bearing bracket (1).

NOTE: It is not necessary to remove the layers of surface protection to do the inspection.

2 Obey the manufacturer's instructions and use a boroscope to examine the inspection areas of the rear control-column support-bearing bracket (1) for cracks.

3 If you find cracks:

a You must contact Pilatus Customer Support before next flight. The address is:

PILATUS AIRCRAFT LTD.,
Customer Technical Support (MCC),
P.O. Box 992
6371 Stans, Switzerland

Fax: + 41 (0) 41 619 67 73

Email: Techsupport@pilatus-aircraft.com.

b Make a report of the inspection results, refer to Step 3.B.(6)(e).

4 If you do not find cracks, make a report of the inspection results, refer to Step 3.B.(6)(e).

(e) Reporting of Inspection Results (Ref. Fig. 14)

1 Make a copy of the Inspection Report Form (Ref. Fig. 14).

2 Complete the Inspection Report Form:

- Give the date of the inspection.
- Give the aircraft details.
- Show the location(s) and dimensions of the crack(s) found (if applicable).
- Add any necessary comments.

NOTE: If there no crack indications, the Inspection Report Form is used to tell Pilatus Aircraft Ltd. the aircraft details.

3 Send or fax the completed form(s) to:

Pilatus Aircraft Ltd.
Customer Technical Support (MCC)
P.O.Box 992
6371 Stans, Switzerland

Fax No. + 41 (0) 41 619 67 73.
Email: Techsupport@pilatus-aircraft.com.

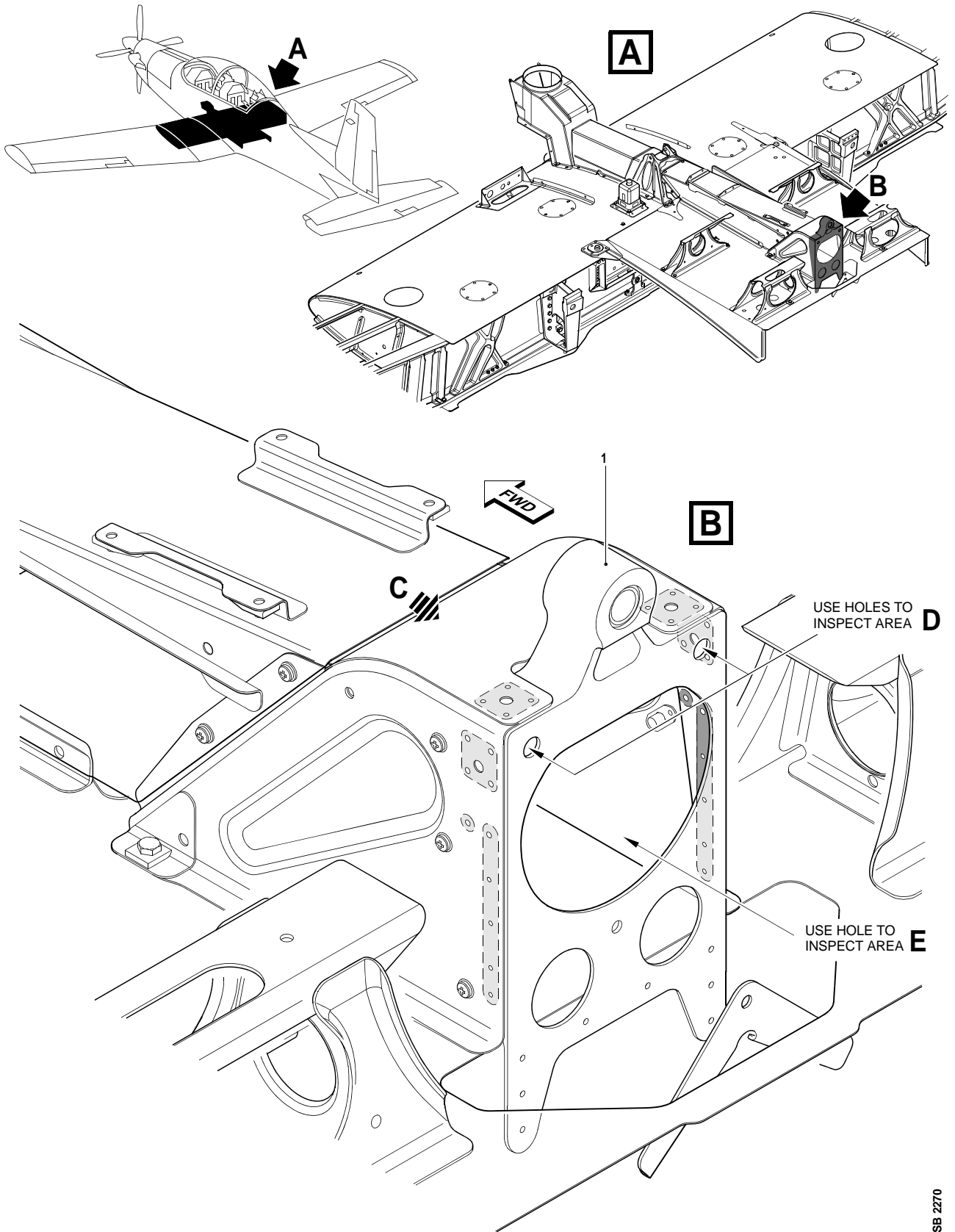

SB 2270

Rear Control-Column Support-Bearing Bracket - Inspection (If Necessary)
Figure 13, Sheet 1 of 2

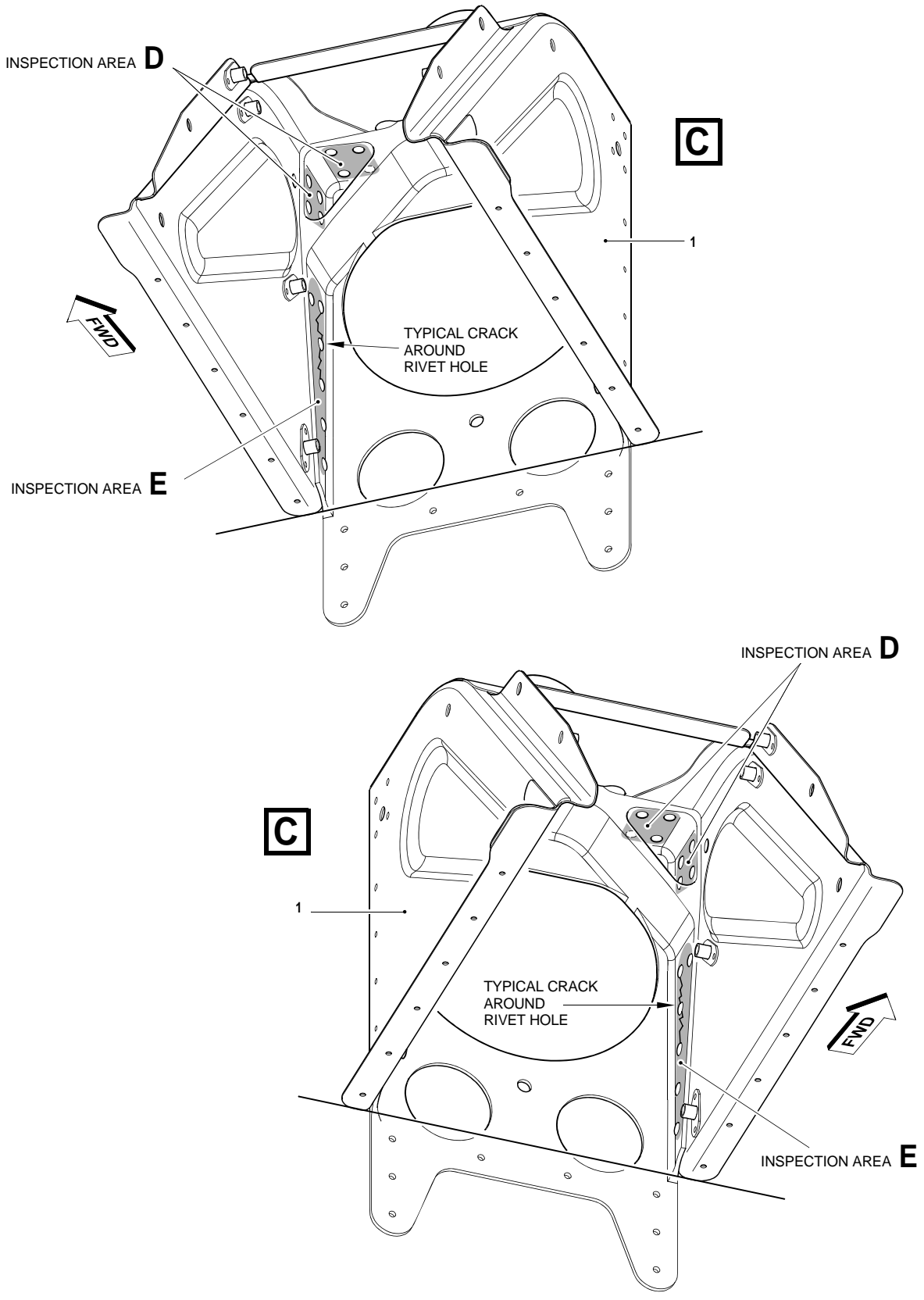

SB 2271

Rear Control-Column Support-Bearing Bracket - Inspection (If Necessary)
Figure 13, Sheet 2 of 2

LH SIDE SUPPORT BEARING BRACKET

| | | | |
|----------------|---------------|---------------------|-----------|
| DATE: | AIRCRAFT MSN: | FLYING HOURS: | LANDINGS: |
| CRACK 1 LENGTH | mm | ADDITIONAL COMMENTS | |
| CRACK 2 LENGTH | mm | | |
| CRACK 3 LENGTH | mm | | |
| CRACK 4 LENGTH | mm | | |

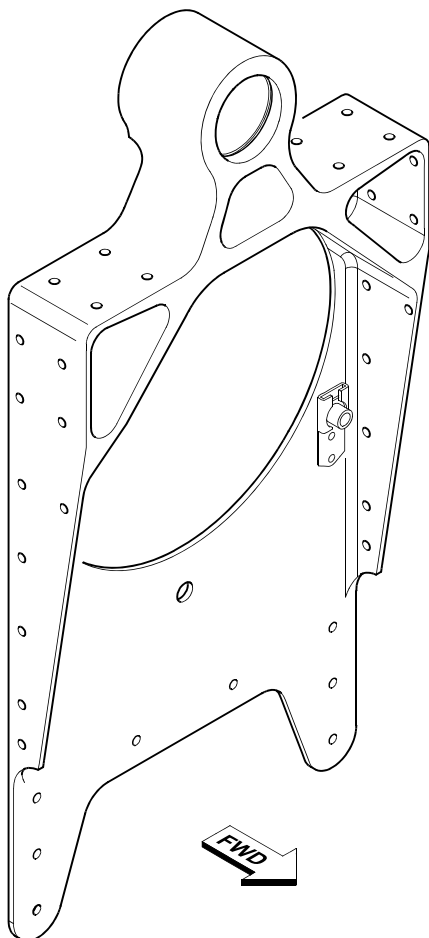
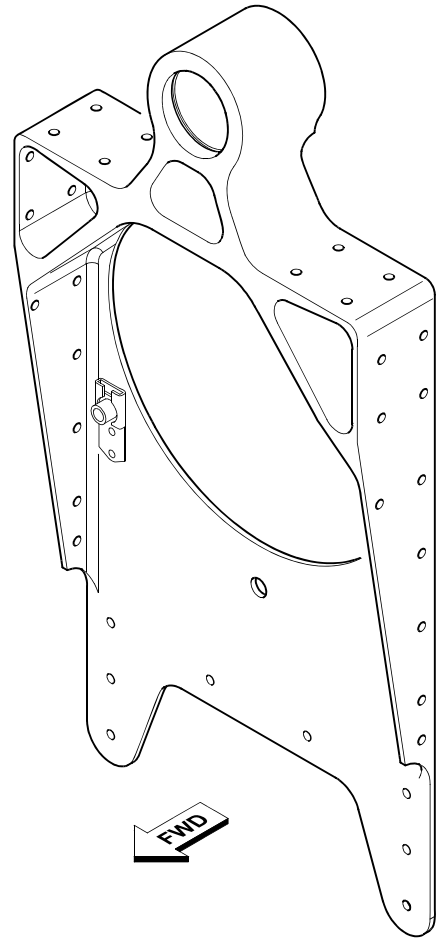

RH SIDE SUPPORT BEARING BRACKET

| | | | |
|----------------|---------------|---------------------|-----------|
| DATE: | AIRCRAFT MSN: | FLYING HOURS: | LANDINGS: |
| CRACK 1 LENGTH | mm | ADDITIONAL COMMENTS | |
| CRACK 2 LENGTH | mm | | |
| CRACK 3 LENGTH | mm | | |
| CRACK 4 LENGTH | mm | | |

SB 2304

Rear Control-Column Support-Bearing Bracket- Inspection Form
Figure 14

(7) Inspection and, if Necessary, Replacement of the Lever on the Rear Control-Column (Ref. Fig. 15)

NOTE: The lever (P/N 527.30.09.027) is part of the lever assembly (P/N 527.30.09.028).

NOTE: Only personnel that are qualified and authorized by their designated Airworthiness Authorities are allowed to do this test.

(a) Do the conductivity test to find the material of the lever (Ref. IPC, 27-10-01) on the rear control-column.

1 Remove the dirt and grease from the areas (where you will do the test) with the absorbent paper (Material No. P02-031) made moist with the solvent (Material No. P01-010).

NOTE: It is not necessary to remove the layers of surface protection (including paint) to do the test.

2 Do a check of the conductivity of the reference plates:

a Make sure the conductivity measurement equipment has been calibrated (Ref. Step at beginning of Para. 3.B.).

b Put the eddy current probe in position on the reference plates (P/N 513.57.09.149 and P/N 513.57.09.150).

c Record the value shown on the test equipment.

NOTE: Make sure the temperature of the reference plates (P/N 513.57.09.149 and P/N 513.57.09.150) is approximately the same as the lever (P/N 527.30.09.027).

3 Put the eddy current probe in position on the lever.

4 Record the value shown on the test equipment.

5 Compare the value recorded above with the values recorded in 3.B.(7)(a)2c and determine if the lever assembly is manufactured from AA2024-T351 or AA2124-T851.

6 Do Steps 3.B.(7)(a)3 thru 5 again to make sure the result is the same.

7 Write the type of material that the lever is made from on the Status of Parts Form (Ref. Fig. 29).

(b) If you find a lever made from AA2024-T351, continue this Service Bulletin from Step 3.B.(7)(d).

(c) If you find a lever made from AA2124-T851, re-identify it (Ref. Para. 2.D.) and continue this Service Bulletin from Step 3.B.(8).

(d) Replace the lever (Ref. Fig. 15):

NOTE: Step 3.B.(7)(d) is only applicable to levers made from AA2024-T351.

1 Remove the nut (4), the washers (3) and the bolt (2).

- 2 Move the forward and aft channels (5) clear of the lever assembly, (1).
- 3 Remove, and discard, the cotter pin (19).
- 4 Remove the nut (20), the washer (18), the washer (14) and the bolt (13).
- 5 Disconnect the rear control column assembly (24) from the rod assembly (23).
- 6 Remove, and discard, the cotter pin (17).
- 7 Remove the nut (16), the washer (15), the washer (12) (if installed) and the bolt (11).
- 8 Remove the rear control column assembly (10) from the aircraft.
- 9 Remove, and discard, the cotter pin (9).
- 10 Remove the nut (8), the washer (7), the special washer (6) and the special bolt (21) from the rear control-column support-bearing bracket (22).
- 11 Remove, and discard, the lever assembly (1) from the aircraft.
- 12 Put the new lever assembly (1) (P/N 527.30.09.223) in position in the aircraft.
- 13 Put a layer of the grease (Material No. P04-028) on the shank of the special bolt (21).
- 14 Install the special bolt (21), the special washer (6), the washer (7) and the nut (8).
- 15 Torque the nut (8) to between 7 and 8 Nm (60 and 70 lb in).
- 16 Safety the nut (8) with the new cotter pin (9) (P/N 940.17.02.350).
- 17 Put the control lever assembly (10) in the aircraft and align:
 - The attachment hole in the new lever assembly (1)
 - The attachment hole in the control lever assembly (10).
- 18 Put a layer of the grease (Material No. P04-028) on the shank of the bolt (11).
- 19 Install the bolt (11), the washer (12) (if removed), the washer (15) and the nut (16).
- 20 Torque the nut (16) to between 7 and 8 Nm (60 and 70 lb in).
- 21 Safety the nut (16) with the new cotter pin (17) (P/N 940.17.02.340).
- 22 Put the control rod (24) in the position and align:
 - The attachment hole in the control lever assembly (10)
 - The attachment hole in the control rod (24)
 - The attachment hole in the rear link assembly (23).

- 23 Put a layer of the grease (Material No. P04-028) on the shank of the bolt (13).
- 24 Install the bolt (13), the washer (14), the washer (18) and the nut (20).
- 25 Torque the nut (20) to between 7 and 8 Nm (60 and 70 lb in).
- 26 Safety the nut (20) with the new cotter pin (19) (P/N 940.17.02.340).
- 27 Move the forward and aft channels (5) towards the lever assembly, (1).
- 28 Put the bolt (2) through the forward channel (5), then through the new lever assembly, (1), then the aft channel (5).
- 29 Install the bolt (2), the washers (3) and the nut (4).

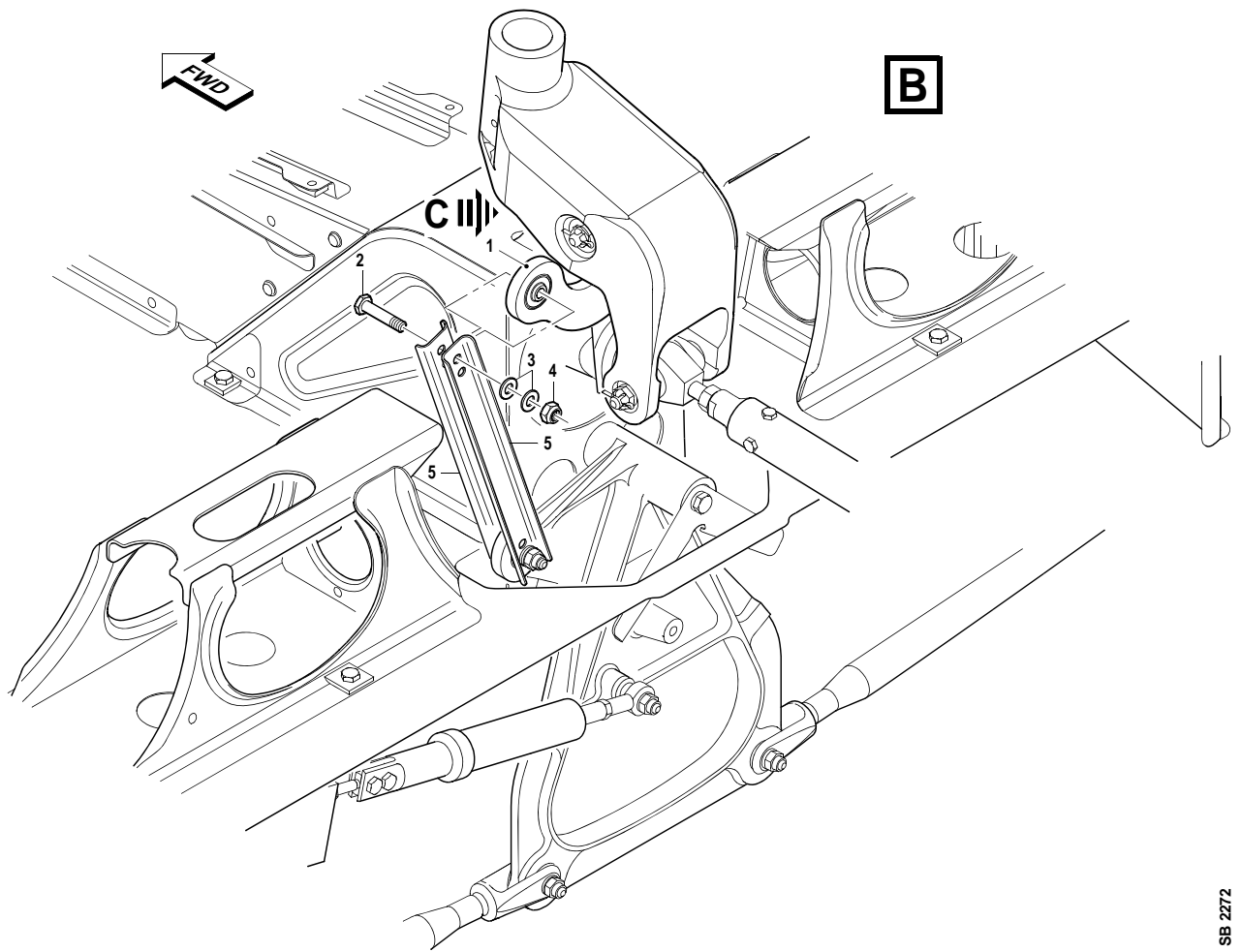
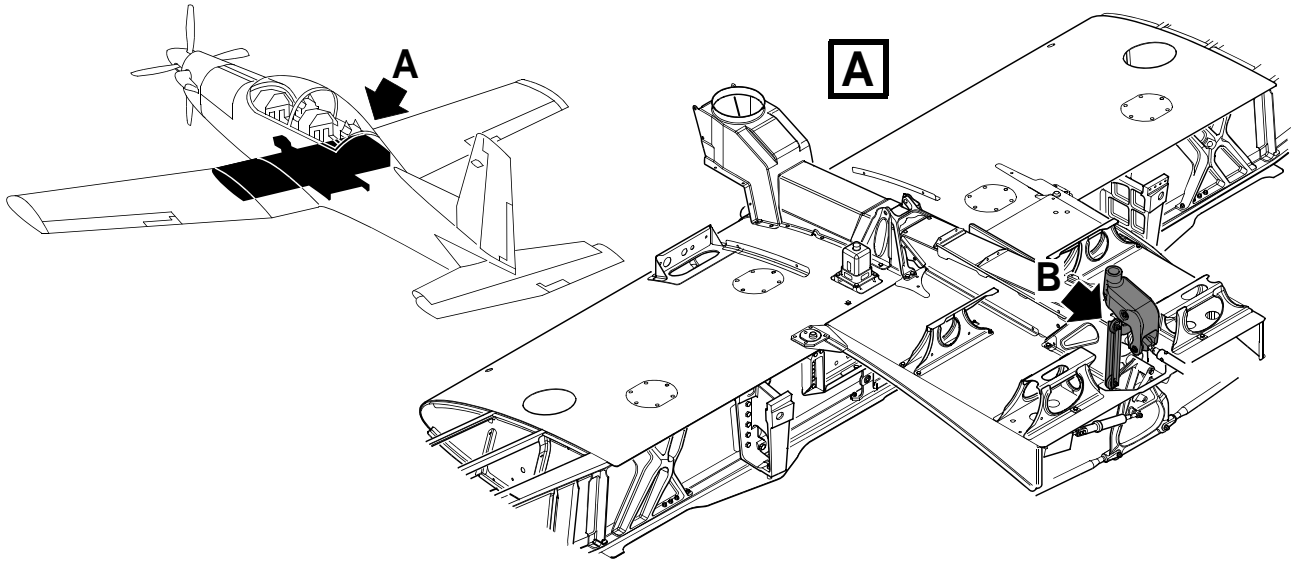

Inspection / Replacement of the Lever on the Rear Control Column
Figure 15, Sheet 1 of 2

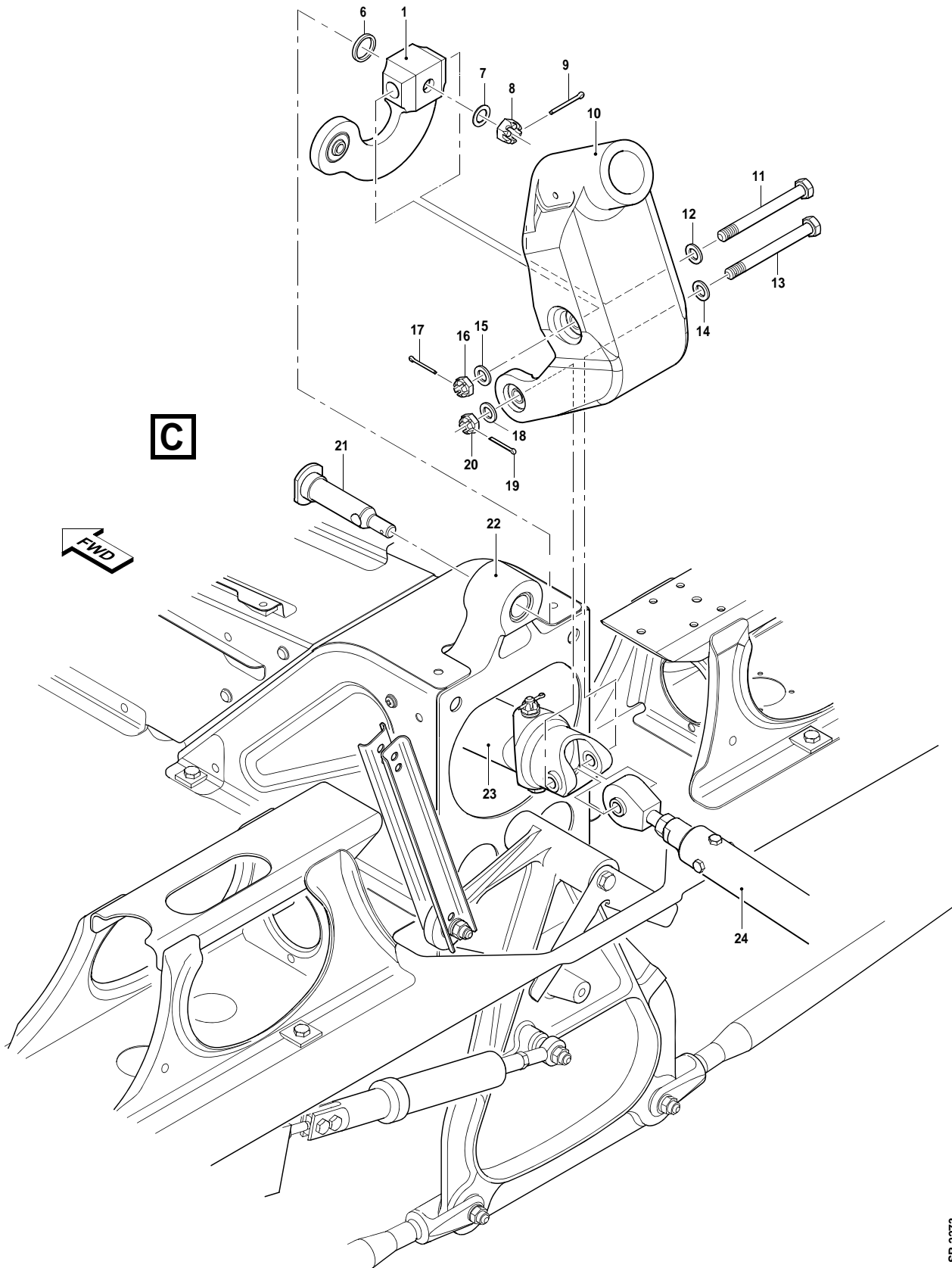

Inspection / Replacement of the Lever on the Rear Control Column
Figure 15, Sheet 2 of 2

SB 2273

(8) Inspection of the elevator center control rod

NOTE: Only personnel that are qualified and authorized by their designated Airworthiness Authorities are allowed to do this test.

NOTE: This Step is only applicable to elevator center control-rod, P/N 527.30.09.015.

(a) Do a check to identify which center control rod is installed:

- 1 If the rod has the rod end parts installed with four rivets, it's P/N 527.30.09.015, continue the Service Bulletin from Step 3.B.(8)(b).
- 2 If the rod does not have the rod end parts installed with four rivets, it's P/N 527.30.09.082, continue the Service Bulletin from Step 3.B.(9).

(b) Disconnect the elevator center control-rod (P/N 527.30.09.015) (Ref. Fig. 16):

- 1 Remove, and discard, the cotter pin (3).
- 2 Remove the nut (5), the washer (4) and the bolt (1).
- 3 Disconnect the elevator center control-rod (2).
- 4 Measure, and make a note of, the distance between:
 - The center of the hole for the attachment bolt (1)
 - The FWD end of the tube (8) on the control rod (2).
- 5 Loosen the lock nut (7) sufficiently to turn the end fitting (6).
- 6 Hold the lock nut (7) and remove the end fitting (6).

(c) Do an inspection for cracks (Ref. Fig. 16):

- 1 Put the boroscope into the elevator center control-rod (2). Do this through the hole for the end fitting (6).
- 2 Obey the manufacturer's instructions and use the boroscope to examine the eight inspection areas of the elevator center control-rod (2) for cracks.

(d) If you find cracks:

- 1 You must contact Pilatus Customer Support before next flight. The address is:

PILATUS AIRCRAFT LTD.,
Customer Technical Support (MCC),
P.O. Box 992
6371 Stans, Switzerland

Fax: + 41 (0) 41 619 67 73
Email: Techsupport@pilatus-aircraft.com.

- 2 Make a report of the inspection results, refer to Step 3.B.(8)(g).

- (e) If you do not find cracks, make a report of the inspection results, refer Step 3.B.(8)(g).
- (f) Connect the elevator center control-rod:
- 1 Install the end fitting (6).
 - 2 Adjust the end fitting (6) until the distance between:
 - The center of the hole for the attachment bolt (1)
 - The FWD end of the tube (8) on the control rod (2)is the same as noted in Step 3.B.(8)(b)4.
 - 3 Tighten the lock nut (7).
 - 4 Put the elevator center control-rod (2) in position.
 - 5 Install the bolt (1), the washer (4) and the nut (5).
- NOTE:** If you must do an inspection of the elevator rear control-rod (Ref. 3.B.(9), you can do Steps 3.B.(8)(f)6 and 3.B.(8)(f)7 when you do Step 3.B.(9)(f)6.
- 6 Do the adjustment / test of the elevator controls (Ref. AMM, 27-30-00, Page Block 501).
 - 7 Safety the nut (5) with the new cotter pin (3) (P/N 940.17.02.340).
- (g) Report the Inspection Results
- 1 Make a copy of the Inspection Report Form(s) (Ref. Fig. 17).
 - 2 Complete the Inspection Report Form:
 - Give the date of the inspection.
 - Give the aircraft details.
 - Show the location(s) and dimensions of the crack(s) found (if applicable).
 - Add any necessary comments.
- NOTE:** If there are no crack indications, the Inspection Report Form is used to tell Pilatus Aircraft Ltd. the aircraft details.
- 3 Send or fax the completed form(s) to:

Pilatus Aircraft Ltd.
Customer Technical Support (MCC)
P.O.Box 992
6371 Stans, Switzerland

Fax No. + 41 (0) 41 619 67 73.
Email: Techsupport@pilatus-aircraft.com.

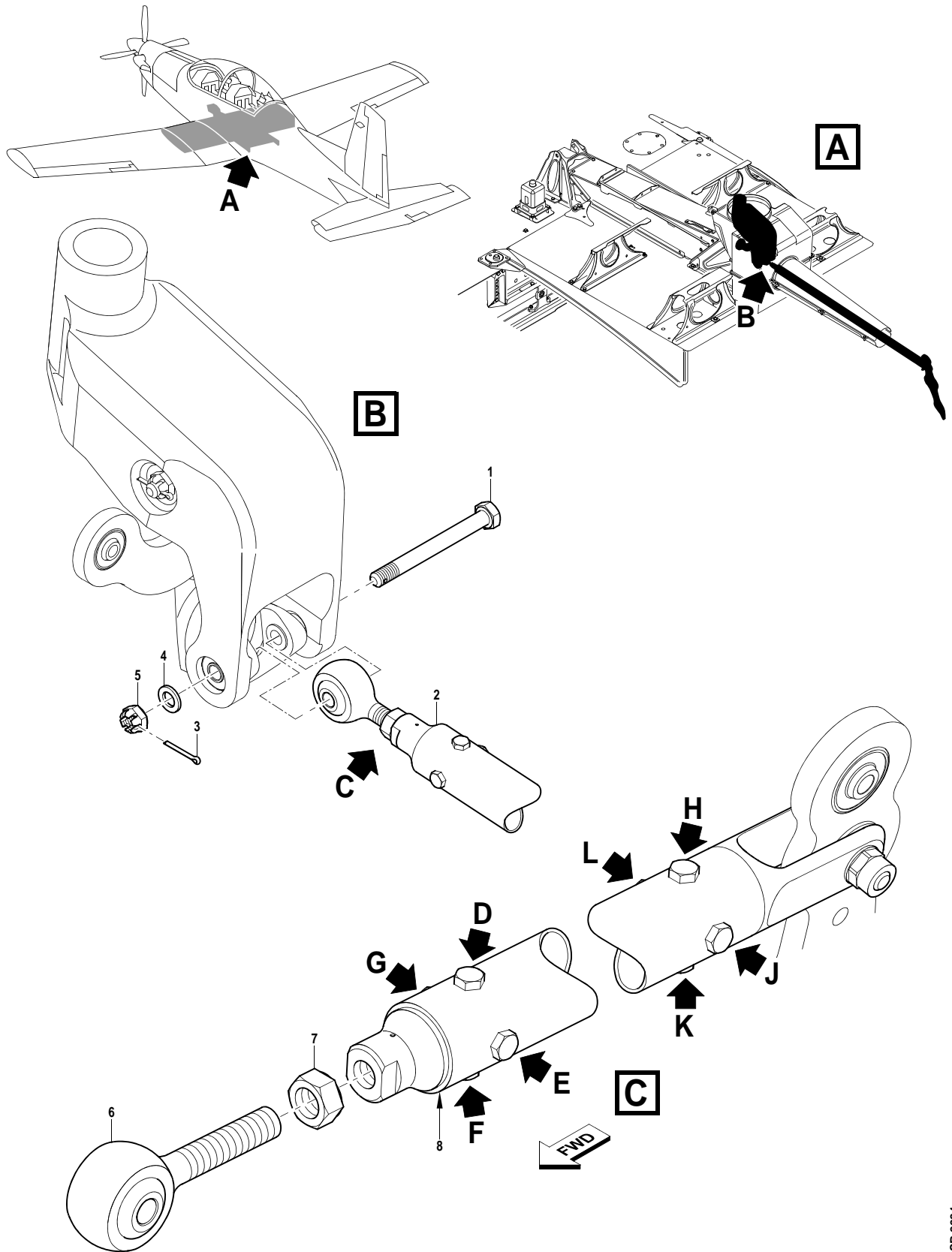

Elevator Center Control-Rod - Inspection (If Necessary)
Figure 16

D

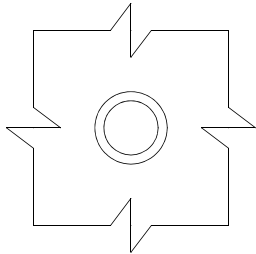

| | | | |
|----------------|---------------|---------------------|-----------|
| DATE: | AIRCRAFT MSN: | FLYING HOURS: | LANDINGS: |
| CRACK 1 LENGTH | mm | ADDITIONAL COMMENTS | |
| CRACK 2 LENGTH | mm | | |
| CRACK 3 LENGTH | mm | | |
| CRACK 4 LENGTH | mm | | |

E

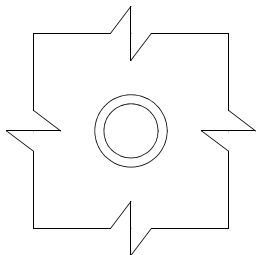

| | | | |
|----------------|---------------|---------------------|-----------|
| DATE: | AIRCRAFT MSN: | FLYING HOURS: | LANDINGS: |
| CRACK 1 LENGTH | mm | ADDITIONAL COMMENTS | |
| CRACK 2 LENGTH | mm | | |
| CRACK 3 LENGTH | mm | | |
| CRACK 4 LENGTH | mm | | |

F

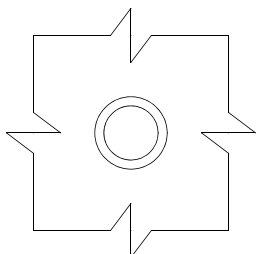

| | | | |
|----------------|---------------|---------------------|-----------|
| DATE: | AIRCRAFT MSN: | FLYING HOURS: | LANDINGS: |
| CRACK 1 LENGTH | mm | ADDITIONAL COMMENTS | |
| CRACK 2 LENGTH | mm | | |
| CRACK 3 LENGTH | mm | | |
| CRACK 4 LENGTH | mm | | |

G

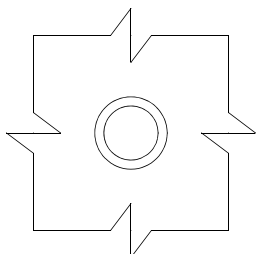

| | | | |
|----------------|---------------|---------------------|-----------|
| DATE: | AIRCRAFT MSN: | FLYING HOURS: | LANDINGS: |
| CRACK 1 LENGTH | mm | ADDITIONAL COMMENTS | |
| CRACK 2 LENGTH | mm | | |
| CRACK 3 LENGTH | mm | | |
| CRACK 4 LENGTH | mm | | |

SB 2293

Elevator Center Control-Rod - Inspection Form
Figure 17, Sheet 1 of 2

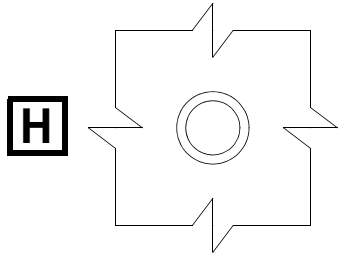

| | | | |
|----------------|---------------|---------------------|-----------|
| DATE: | AIRCRAFT MSN: | FLYING HOURS: | LANDINGS: |
| CRACK 1 LENGTH | mm | ADDITIONAL COMMENTS | |
| CRACK 2 LENGTH | mm | | |
| CRACK 3 LENGTH | mm | | |
| CRACK 4 LENGTH | mm | | |

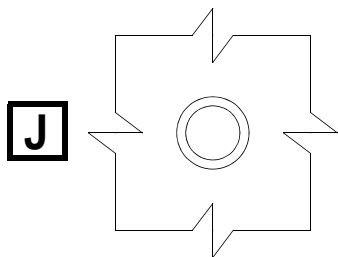

| | | | |
|----------------|---------------|---------------------|-----------|
| DATE: | AIRCRAFT MSN: | FLYING HOURS: | LANDINGS: |
| CRACK 1 LENGTH | mm | ADDITIONAL COMMENTS | |
| CRACK 2 LENGTH | mm | | |
| CRACK 3 LENGTH | mm | | |
| CRACK 4 LENGTH | mm | | |

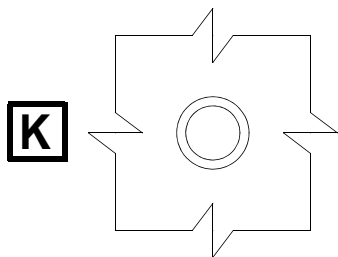

| | | | |
|----------------|---------------|---------------------|-----------|
| DATE: | AIRCRAFT MSN: | FLYING HOURS: | LANDINGS: |
| CRACK 1 LENGTH | mm | ADDITIONAL COMMENTS | |
| CRACK 2 LENGTH | mm | | |
| CRACK 3 LENGTH | mm | | |
| CRACK 4 LENGTH | mm | | |

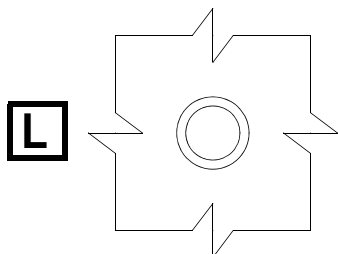

| | | | |
|----------------|---------------|---------------------|-----------|
| DATE: | AIRCRAFT MSN: | FLYING HOURS: | LANDINGS: |
| CRACK 1 LENGTH | mm | ADDITIONAL COMMENTS | |
| CRACK 2 LENGTH | mm | | |
| CRACK 3 LENGTH | mm | | |
| CRACK 4 LENGTH | mm | | |

(9) Inspection of the elevator rear control rod

NOTE: Only personnel that are qualified and authorized by their designated Airworthiness Authorities are allowed to do this test.

NOTE: This Step is only applicable to elevator rear control-rod, P/N 527.30.09.016.

(a) Do a check to identify which rear control rod is installed:

- 1 If the rod has the rod end parts installed with four rivets, it's P/N 527.30.09.016, continue the Service Bulletin from Step 3.B.(9)(b).
- 2 If the rod does not have the rod end parts installed with four rivets, it's P/N 527.30.09.083, continue the Service Bulletin from Step 3.B.(10).

(b) Disconnect the elevator rear control-rod (P/N 527.30.09.016) (Ref. Fig. 18):

- 1 Remove the nut (4), the washer (3) and the bolt (1).
- 2 Disconnect the elevator rear control-rod (2).
- 3 Measure, and make a note of, the distance between:
 - The center of the hole for the attachment bolt (1)
 - The AFT end of the tube (7) on the control rod (2).
- 4 Loosen the lock nut (5) sufficiently to turn the end fitting (6).
- 5 Hold the lock nut (5) and remove the end fitting (6).

(c) Do an inspection for cracks (Ref. Fig. 18):

- 1 Put the boroscope into the elevator rear control-rod (2) (P/N 527.30.09.016). Do this through the hole for the end fitting (6).
- 2 Obey the manufacturer's instructions and use the boroscope to examine the eight inspection areas of the elevator rear control-rod (2) (P/N 527.30.09.016) for cracks.

(d) If you find cracks:

- 1 You must contact Pilatus Customer Support before next flight. The address is:

PILATUS AIRCRAFT LTD.,
Customer Technical Support (MCC),
P.O. Box 992
6371 Stans, Switzerland

Fax: + 41 (0) 41 619 67 73
Email: Techsupport@pilatus-aircraft.com.

- 2 Make a report of the inspection results, refer to Step 3.B.(12)(g).

(e) If you do not find cracks, make a report of the inspection results, refer Step 3.B.(9)(g).

- (f) Connect the elevator rear control-rod:
- 1 Install the end fitting (6).
 - 2 Adjust the end fitting (6) until the distance between:
 - The center of the hole for the attachment bolt (1)
 - The AFT end of the tube (7) on the control rod (2)is the same as noted in Step 3.B.(9)(b)3.
 - 3 Tighten the lock nut (5).
 - 4 Put the elevator center control-rod (2) in position.
 - 5 Install the bolt (1), the washer (3) and the nut (4).
 - 6 Do the adjustment / test of the elevator controls (Ref. AMM, 27-30-00, Page Block 501).

(g) Report the Inspection Results

- 1 Make a copy of the Inspection Report Form(s) (Ref. Fig. 19).
- 2 Complete the Inspection Report Form:
 - Give the date of the inspection.
 - Give the aircraft details.
 - Show the location(s) and dimensions of the crack(s) found (if applicable).
 - Add any necessary comments.

NOTE: If there are no crack indications, the Inspection Report Form is used to tell Pilatus Aircraft Ltd. the aircraft details.

- 3 Send or fax the completed form(s) to:

Pilatus Aircraft Ltd.
Customer Technical Support (MCC)
P.O.Box 992
6371 Stans, Switzerland

Fax No. + 41 (0) 41 619 67 73.
Email: Techsupport@pilatus-aircraft.com.

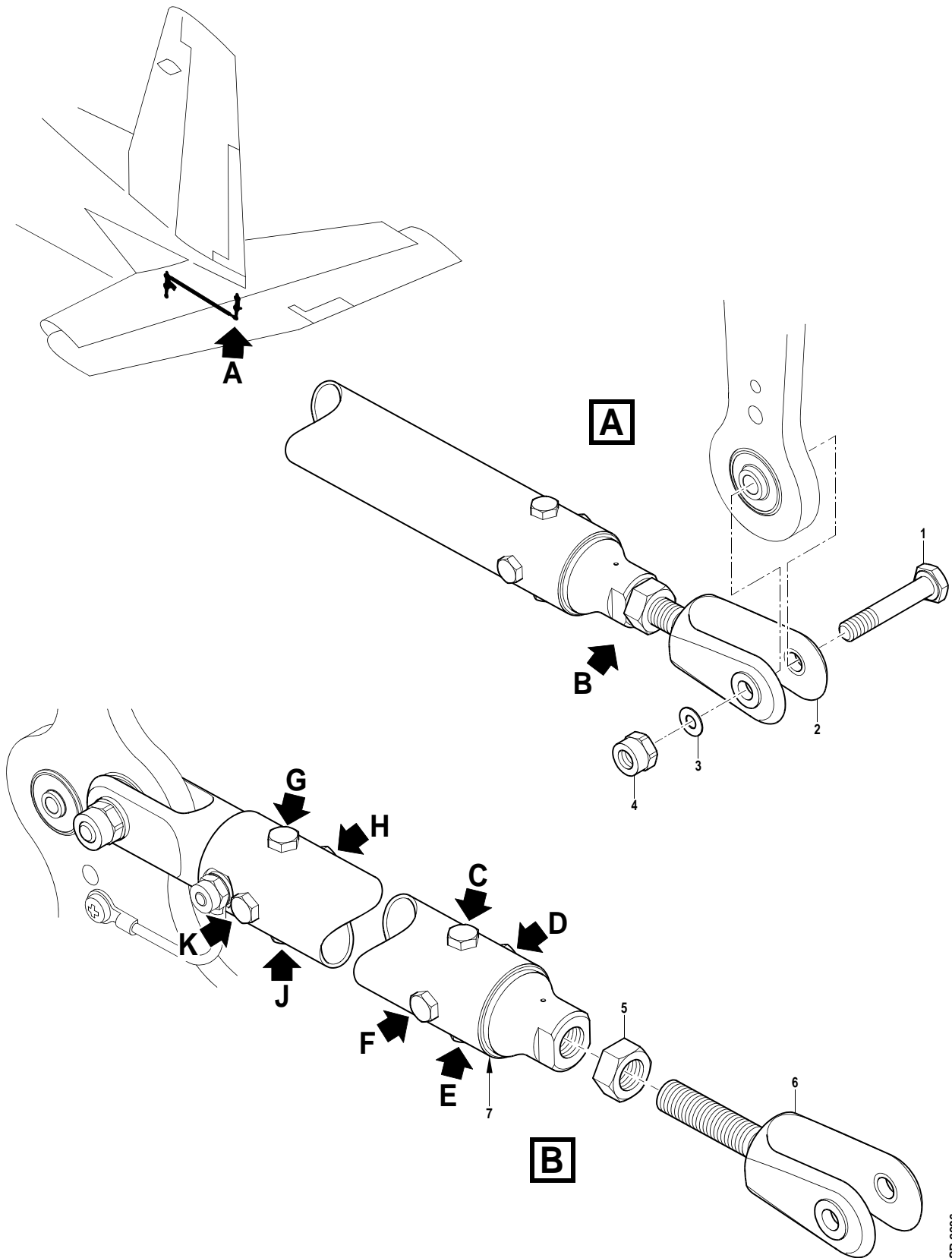

SB 2296

Elevator Rear Control-Rod - Inspection (If Necessary)
Figure 18

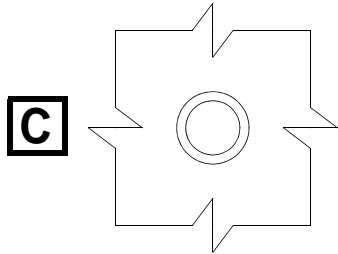

| | | | |
|----------------|---------------|---------------------|-----------|
| DATE: | AIRCRAFT MSN: | FLYING HOURS: | LANDINGS: |
| CRACK 1 LENGTH | mm | ADDITIONAL COMMENTS | |
| CRACK 2 LENGTH | mm | | |
| CRACK 3 LENGTH | mm | | |
| CRACK 4 LENGTH | mm | | |

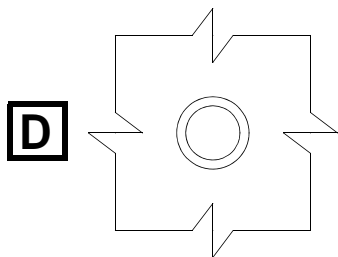

| | | | |
|----------------|---------------|---------------------|-----------|
| DATE: | AIRCRAFT MSN: | FLYING HOURS: | LANDINGS: |
| CRACK 1 LENGTH | mm | ADDITIONAL COMMENTS | |
| CRACK 2 LENGTH | mm | | |
| CRACK 3 LENGTH | mm | | |
| CRACK 4 LENGTH | mm | | |

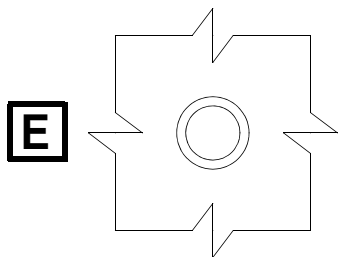

| | | | |
|----------------|---------------|---------------------|-----------|
| DATE: | AIRCRAFT MSN: | FLYING HOURS: | LANDINGS: |
| CRACK 1 LENGTH | mm | ADDITIONAL COMMENTS | |
| CRACK 2 LENGTH | mm | | |
| CRACK 3 LENGTH | mm | | |
| CRACK 4 LENGTH | mm | | |

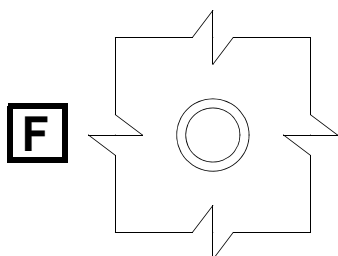

| | | | |
|----------------|---------------|---------------------|-----------|
| DATE: | AIRCRAFT MSN: | FLYING HOURS: | LANDINGS: |
| CRACK 1 LENGTH | mm | ADDITIONAL COMMENTS | |
| CRACK 2 LENGTH | mm | | |
| CRACK 3 LENGTH | mm | | |
| CRACK 4 LENGTH | mm | | |

G

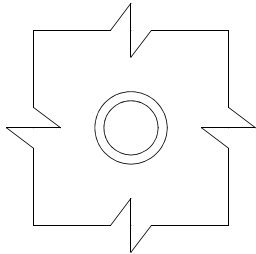

| | | | |
|----------------|---------------|---------------------|-----------|
| DATE: | AIRCRAFT MSN: | FLYING HOURS: | LANDINGS: |
| CRACK 1 LENGTH | mm | ADDITIONAL COMMENTS | |
| CRACK 2 LENGTH | mm | | |
| CRACK 3 LENGTH | mm | | |
| CRACK 4 LENGTH | mm | | |

H

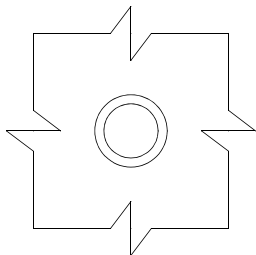

| | | | |
|----------------|---------------|---------------------|-----------|
| DATE: | AIRCRAFT MSN: | FLYING HOURS: | LANDINGS: |
| CRACK 1 LENGTH | mm | ADDITIONAL COMMENTS | |
| CRACK 2 LENGTH | mm | | |
| CRACK 3 LENGTH | mm | | |
| CRACK 4 LENGTH | mm | | |

J

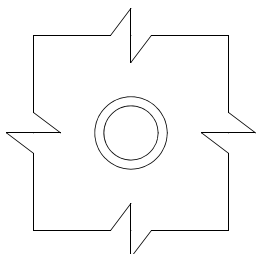

| | | | |
|----------------|---------------|---------------------|-----------|
| DATE: | AIRCRAFT MSN: | FLYING HOURS: | LANDINGS: |
| CRACK 1 LENGTH | mm | ADDITIONAL COMMENTS | |
| CRACK 2 LENGTH | mm | | |
| CRACK 3 LENGTH | mm | | |
| CRACK 4 LENGTH | mm | | |

K

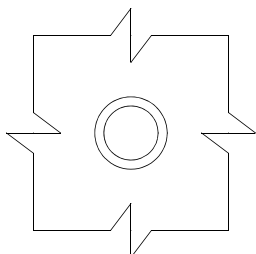

| | | | |
|----------------|---------------|---------------------|-----------|
| DATE: | AIRCRAFT MSN: | FLYING HOURS: | LANDINGS: |
| CRACK 1 LENGTH | mm | ADDITIONAL COMMENTS | |
| CRACK 2 LENGTH | mm | | |
| CRACK 3 LENGTH | mm | | |
| CRACK 4 LENGTH | mm | | |

SB 2298

Elevator Rear Control-Rod - Disconnection, Connection and Inspection
Figure 19, Sheet 2 of 2

(10) Inspection and, if Necessary, Replacement of the Bearing in the Forward Control-Column (Ref. Fig. 20)

NOTE: The bearing (P/N 527.30.09.029) is part of the bearing assembly (P/N 527.30.09.030).

NOTE: Only personnel that are qualified and authorized by their designated Airworthiness Authorities are allowed to do this test.

(a) Do the conductivity test to find the material of the bearing (Ref. Fig. 20) on the fwd control-column (Ref. IPC, 27-10-01).

1 Remove the dirt and grease from the areas (where you will do the test) with the absorbent paper (Material No. P02-031) made moist with the solvent (Material No. P01-010).

NOTE: It is not necessary to remove the layers of surface protection (including paint) to do the test.

2 Do a check of the conductivity of the reference plates:

a Make sure the conductivity measurement equipment has been calibrated (Ref. Step at beginning of Para. 3.B.).

b Put the eddy current probe in position on the reference plates (P/N 513.57.09.149 and P/N 513.57.09.150).

c Record the value shown on the test equipment.

NOTE: Make sure the temperature of the reference plates (P/N 513.57.09.149 and P/N 513.57.09.150) is approximately the same as the bearing (P/N 527.30.09.029).

3 Put the eddy current probe in position on the bearing.

4 Record the value shown on the test equipment.

5 Compare the value recorded above with the values recorded in Step 3.B.(10)(a)2c and determine if the bearing is manufactured from AA2024-T351 or AA2124-T851.

6 Do Steps 3.B.(10)(a)3 thru 5 again to make sure the result is the same.

7 Write the type of material that the bearing (P/N 527.30.09.029) is made from on the Status of Parts Form (Ref. Fig. 29).

(b) If you find a bearing made from AA2024-T351, continue this Service Bulletin from Step 3.B.(10)(d).

(c) If you find a bearing made from AA2124-T851, re-identify it (Ref. Para. 2.D.) and continue this Service Bulletin from Step 3.B.(11).

(d) Replace the bearing assembly (Ref. Fig. 20):

NOTE: Step 3.B.(10)(d) is only applicable to bearings made from AA2024-T351.

- 1 Remove, and discard, the cotter pin (11).
- 2 Remove the nut (10), the washer (9), the washer (8) (if installed) and the bolt (7).
- 3 Move the control lever assembly (6) towards the rear of the aircraft to get access to the bearing assembly (2).
- 4 Remove, and discard, the cotter pin (4).
- 5 Remove the nut (3), the washer (5), the special washer (1) and the special bolt (13) from the rear control-column support bearing assembly (12).
- 6 Remove, and discard, the bearing assembly (2) from the aircraft.
- 7 Put the new bearing assembly (2) (P/N 527.30.09.221) in position in the aircraft.
- 8 Put a layer of the grease (Material No. P04-028) on the shank of the special bolt (13).
- 9 Install the special bolt (13), the special washer (1), the washer (5) and the nut (3).
- 10 Torque the nut (3) to between 7 and 8 Nm (60 and 70 lb in).
- 11 Install the new cotter pin (4) (P/N 940.17.02.350).
- 12 Move the control lever assembly (6) towards the front of the aircraft to align:
 - The attachment hole in the new bearing assembly (2)
 - The attachment hole in the control lever assembly (6).
- 13 Put a layer of the grease (Material No. P04-028) on the shank of the bolt (7).
- 14 Install the bolt (7), the washer (8) (if removed), the washer (9) and the nut (10).
- 15 Torque the nut (10) to between 7 and 8 Nm (60 and 70 lb in).
- 16 Install the new cotter pin (11) (P/N 940.17.02.340).

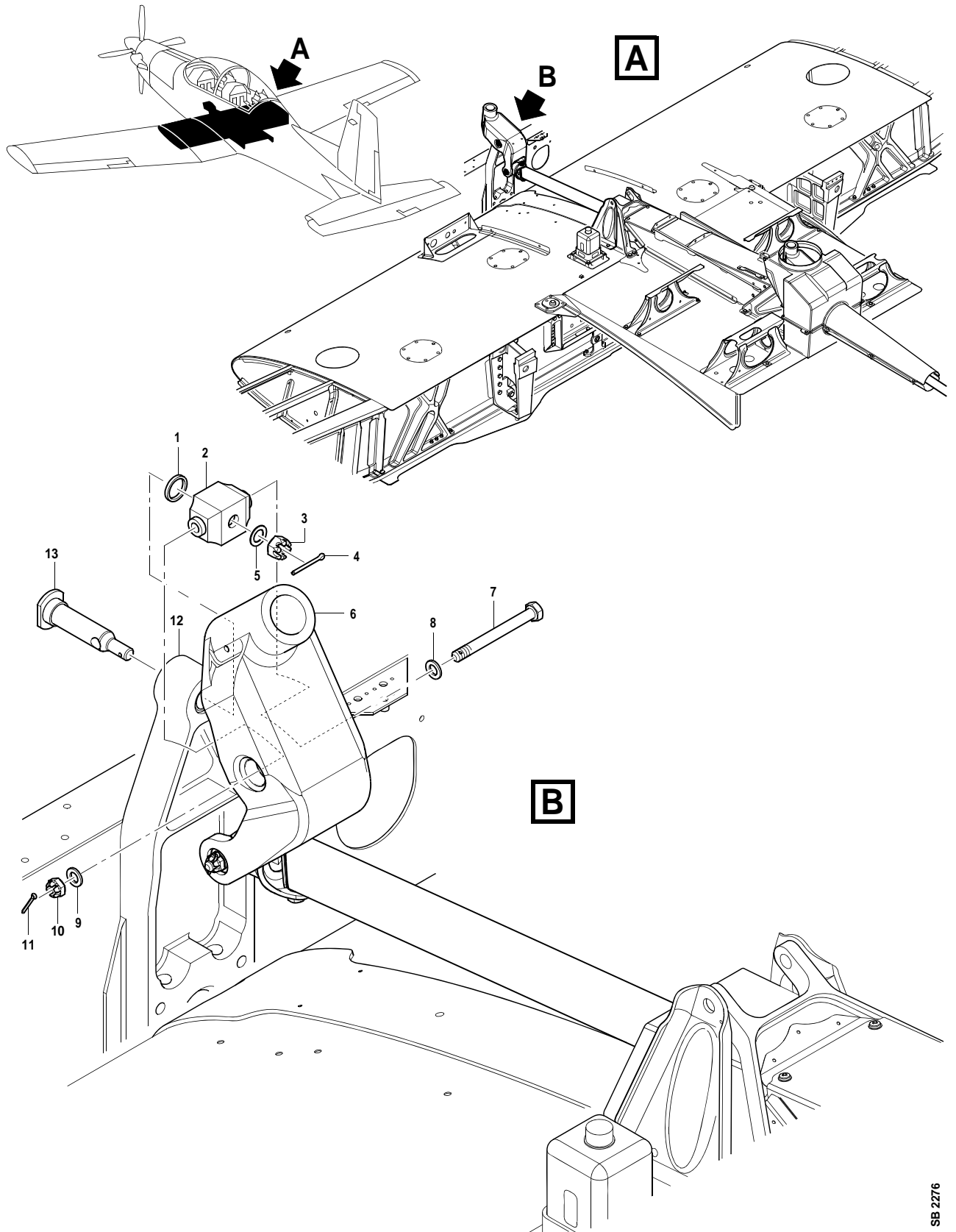

Replacement of the Bearing on the Forward Control Column
Figure 20

(11) Inspection and, if necessary, Replacement of the Shackles on the Elevator Control Cable (Ref. Fig. 21 and Fig. 22)

NOTE: Only personnel that are qualified and authorized by their designated Airworthiness Authorities are allowed to do this test.

(a) Do the conductivity test to find the material of the shackles, P/N 527.30.09.036 and P/N 116.35.07.092 (Ref. IPC, 27-30-01) on the elevator control cable (P/N 527.30.09.005).

- 1 Get access to both attachment points of the elevator control cable (P/N 527.30.09.005) (Ref. IPC, 27-30-01) (Refer to AMM, 27-20-02 for further information).
- 2 Remove the dirt and grease from the areas (where you will do the test) with the absorbent paper (Material No. P02-031) made moist with the solvent (Material No. P01-010).

NOTE: It is not necessary to remove the layers of surface protection (including paint) to do the test.

- 3 Do a check of the conductivity of the reference plates:
 - a Make sure the conductivity measurement equipment has been calibrated (Ref. Step at beginning of Para. 3.B.).
 - b Put the eddy current probe in position on the reference plates (P/N 513.57.09.149 and P/N 513.57.09.150).
 - c Record the value shown on the test equipment.

NOTE: Make sure the temperature of the reference plates (P/N 513.57.09.149 and P/N 513.57.09.150) is approximately the same as the shackles (P/N 527.30.09.036 and P/N 116.35.07.092).

- 4 Put the eddy current probe in position on the FWD shackle (P/N 527.30.09.036).
- 5 Record the value shown on the test equipment.
- 6 Compare the value recorded above with the values recorded in Step 3.B.(11)(a)3c and determine if the shackle is manufactured from AA2024-T351 or AA2124-T851.
- 7 Do Steps 3.B.(11)(a)4 thru 6 again to make sure the result is the same.
- 8 Write the type of material that the FWD shackle (P/N 527.30.09.036) is made from on the Status of Parts Form (Ref. Fig. 29).
- 9 Put the eddy current probe in position on the AFT shackle (P/N 116.35.07.092).
- 10 Record the value shown on the test equipment.

- 11 Compare the value recorded above with the values recorded in Step 3.B.(11)(a)3c and determine if the shackle is manufactured from AA2024-T351 or AA2124-T851.
 - 12 Do Steps 3.B.(11)(a)9 thru 11 again to make sure the result is the same.
 - 13 Write the type of material that the AFT shackle (P/N 116.35.07.092) is made from on the Status of Parts Form (Ref. Fig. 29).
- (b) If you find a shackle (P/N 527.30.09.036) made from AA2024-T351, continue this Service Bulletin from Step 3.B.(11)(e).
 - (c) If you find a shackle (P/N 116.35.07.092) made from AA2024-T351, continue this Service Bulletin from Step 3.B.(11)(f).
 - (d) If you find a shackle (P/N 527.30.09.036 and / or P/N 116.35.07.092) made from AA2124-T851, re-identify them (Ref. Para. 2.D.) and continue this Service Bulletin from Step 3.B.(12).
 - (e) Replace the shackle (P/N 527.30.09.036) (Ref. Fig. 21 and Fig. 22):

NOTE: Step 3.B.(11)(e) is only applicable to shackles (P/N 527.30.09.036) made from AA2024-T351.

- 1 Make sure that the elevator is in the neutral position.
- 2 Install rigging pins (P/Ns 110.85.07.050 and 513.27.72.001) at the front and rear levers (1) and (11).
- 3 At the front lever, identify the control cable (2) (P/N 527.30.09.005).
- 4 Remove and discard the locking clips from the turnbuckles (Refer to AMM, 27-20-02 for further information).
- 5 Loosen the turnbuckles to release the tension from the control cable (2) (P/N 527.30.09.005).
- 6 Remove, and discard, the cotter pin (6), the nut (5), the washer (4) and the bolt (10) that connect the shackle (9) to the control cable (2).
- 7 Remove the nut (7), the washer (8) and the bolt (3) that connect the shackle (9) to the lever (1).
- 8 Remove, and discard, the shackle (9) from the aircraft.
- 9 Use the absorbent paper (Material No. P02-031) made moist with the solvent (Material No. P01-010) and clean the attachment points on the lever (1) and the cable (2).
- 10 Put the new shackle (9) (P/N 527.30.09.229) in position between the lever (1) and the cable (2).
- 11 Put a layer of the corrosion preventative (Material No. P04-039) on the shank of the bolt (3).

- 12 Install the bolt (3), the washer (8) and the nut (7) that connect the shackle (9) to the lever (1).
- 13 Install the bolt (10), the washer (4) and the nut (5) that connect the shackle (9) to the cable (2).
- 14 Safety the nut (5) with the new cotter pin (6) (P/N 940.17.02.340).
- 15 If the shackle (P/N 116.35.07.092) is made from AA2024-T351, continue this Service Bulletin from Step 3.B.(9)(f).
- 16 If the shackle (P/N 116.35.07.092) is made from AA2124-T851, continue this Service Bulletin from Step 3.B.(9)(f)15.

(f) Replace the shackle (P/N 116.35.07.092) (Ref. Fig. 21 and Fig. 22):

NOTE: Step 3.B.(9)(f) is only applicable to shackles (P/N 116.35.07.092) made from AA2024-T351.

NOTE: Steps 3.B.(9)(f)1 thru 5 are only applicable if the shackle (P/N 527.30.09.036) was not replaced.

- 1 Make sure that the elevator is in the neutral position.
- 2 Install rigging pins (P/Ns 110.85.07.050 and 513.27.72.001) at the front and rear levers (1) and (11).
- 3 At the rear lever (11), identify the control cable (16) (P/N 527.30.09.005).
- 4 Remove and discard the locking clips from the turnbuckles (Refer to AMM, 27-20-02 for further information).
- 5 Loosen the turnbuckles to release the tension from the control cable (16) (P/N 527.30.09.005).
- 6 Remove the nut (15), the washer (14) and the bolt (20) that connect the shackle (12) to the lever (11).
- 7 Remove, and discard, the cotter pin (19), the nut (18), the washers (17) and the bolt (13) that connect the shackle (12) to the control cable (16).

NOTE: Pull the control cable (16) rearwards to make the removal of bolt (13) easier.

- 8 Remove, and discard, the shackle (12) from the aircraft.
- 9 Use the absorbent paper (Material No. P02-031) made moist with the solvent (Material No. P01-010) and clean the attachment points on the lever (11) and the cable (16).
- 10 Put the new shackle (12) (P/N 527.30.09.231) in position between the lever (11) and the control cable (16).
- 11 Install the bolt (13), the washers (17) and the nut (18) that connect the shackle (12) to the control cable (16).

- 12 Safety the nut (18) with the new cotter pin (19) (P/N 940.17.02.340).
- 13 Put a layer of the corrosion preventative (Material No. P04-039) on the shank of the bolt (20).
- 14 Install the bolt (20), the washer (14) and the nut (15) that connect the shackle (12) to the lever (11).
- 15 Do the elevator control system, adjustment / test (Ref. AMM, 27-30-00, Page Block 501).

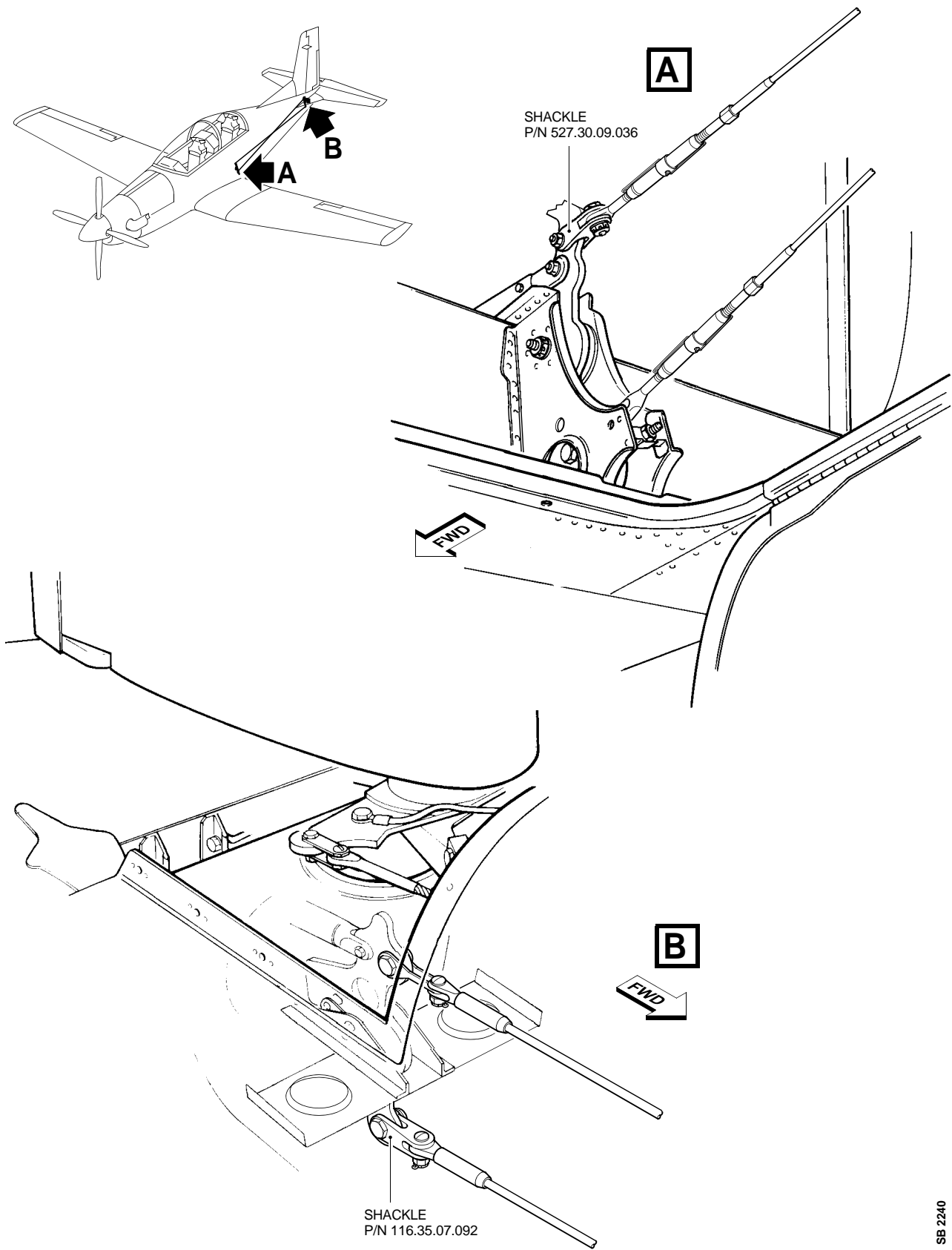

SB 2240

Inspection and, if necessary, Replacement of the Shackles on the Elevator Control Cable
Figure 21

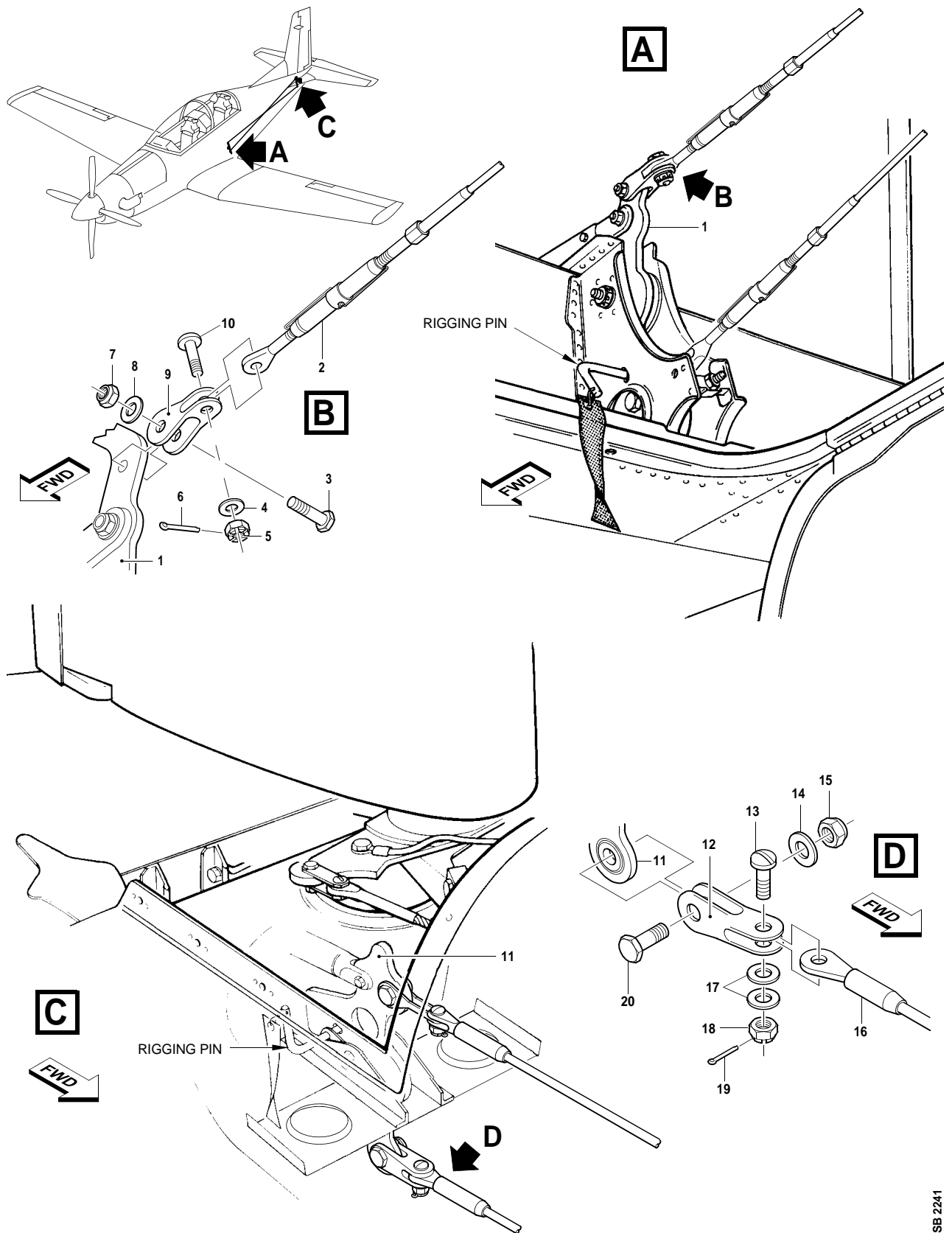

Inspection and, if necessary, Replacement of the Shackles on the Elevator Control Cable
Figure 22

(12) Inspection of the left and right aileron outer control-rods

NOTE: Only personnel that are qualified and authorized by their designated Airworthiness Authorities are allowed to do this test.

NOTE: This Step is only applicable to left and right aileron outer control-rods, P/N 527.10.09.021.

(a) Do a check to identify which outer control rod is installed:

- 1 If the rod has the rod end parts installed with four rivets, it's P/N 527.10.09.021, continue the Service Bulletin from Step 3.B.(12)(b).
- 2 If the rod does not have the rod end parts installed with four rivets, it's P/N 527.10.09.073, continue the Service Bulletin from Step 3.B.(13).

(b) Disconnect the left-aileron outer control-rod (P/N 527.10.09.021) (Ref. Fig. 23):

- 1 Remove the nut (4), the washer (3) and the bolt (1).
- 2 Disconnect the aileron outer control-rod (2).
- 3 Measure, and make a note of, the distance between:
 - The center of the hole for the attachment bolt (1)
 - The outboard end of the tube (5) on the control rod (2).
- 4 Loosen the lock nut (6) sufficiently to turn the end fitting (7).
- 5 Hold the lock nut (6) and remove the end fitting (7).

(c) Do an inspection for cracks (Ref. Fig. 23):

- 1 Put the boroscope into the left aileron outer control-rod (2). Do this through the hole for the end fitting (7).
- 2 Obey the manufacturer's instructions and use the boroscope to examine the eight inspection areas of the left-aileron outer control-rod (2) for cracks.

(d) Do Step 3.B.(12)(a) thru (c) again for the right aileron outer control-rod (P/N 527.10.09.021).

- (e) If you find cracks:
- 1 You must contact Pilatus Customer Support before next flight. The address is:

PILATUS AIRCRAFT LTD.,
Customer Technical Support (MCC),
P.O. Box 992
6371 Stans, Switzerland

Fax: + 41 (0) 41 619 67 73
Email: Techsupport@pilatus-aircraft.com.

- 2 Make a report of the inspection results, refer to Step 3.B.(12)(g).
- (f) If you do not find cracks, make a report of the inspection results, refer Step 3.B.(10)(g).

- (g) Report the Inspection Results

- 1 Make a copy of the Inspection Report Form(s) (Ref. Fig. 24).
- 2 Complete the Inspection Report Form:
 - Give the date of the inspection.
 - Give the aircraft details.
 - Show the location(s) and dimensions of the crack(s) found (if applicable).
 - Add any necessary comments.

NOTE: If there are no crack indications, the Inspection Report Form is used to tell Pilatus Aircraft Ltd. the aircraft details.

- 3 Send or fax the completed form(s) to:

Pilatus Aircraft Ltd.
Customer Technical Support (MCC)
P.O.Box 992
6371 Stans, Switzerland

Fax No. + 41 (0) 41 619 67 73.
Email: Techsupport@pilatus-aircraft.com.

- (h) Connect the left-aileron outer control-rod:
- 1 Install the end fitting (7).
 - 2 Adjust the end fitting (7) until the distance between:
 - The center of the hole for the attachment bolt (1)
 - The outboard end of the tube (5) on the control rod (2)is the same as noted in Step 3.B.(12)(b)3.
 - 3 Tighten the lock nut (6).

- 4 Put the left-aileron outer control-rod (2) in position.
- 5 Install the bolt (1), the washer (3) and the nut (4).
- (i) Do Step 3.B.(12)(h) again for the right aileron outer control-rod (P/N 527.10.09.021).
- (j) Do the adjustment / test of the aileron controls (Ref. AMM, 27-10-00, Page Block 501).

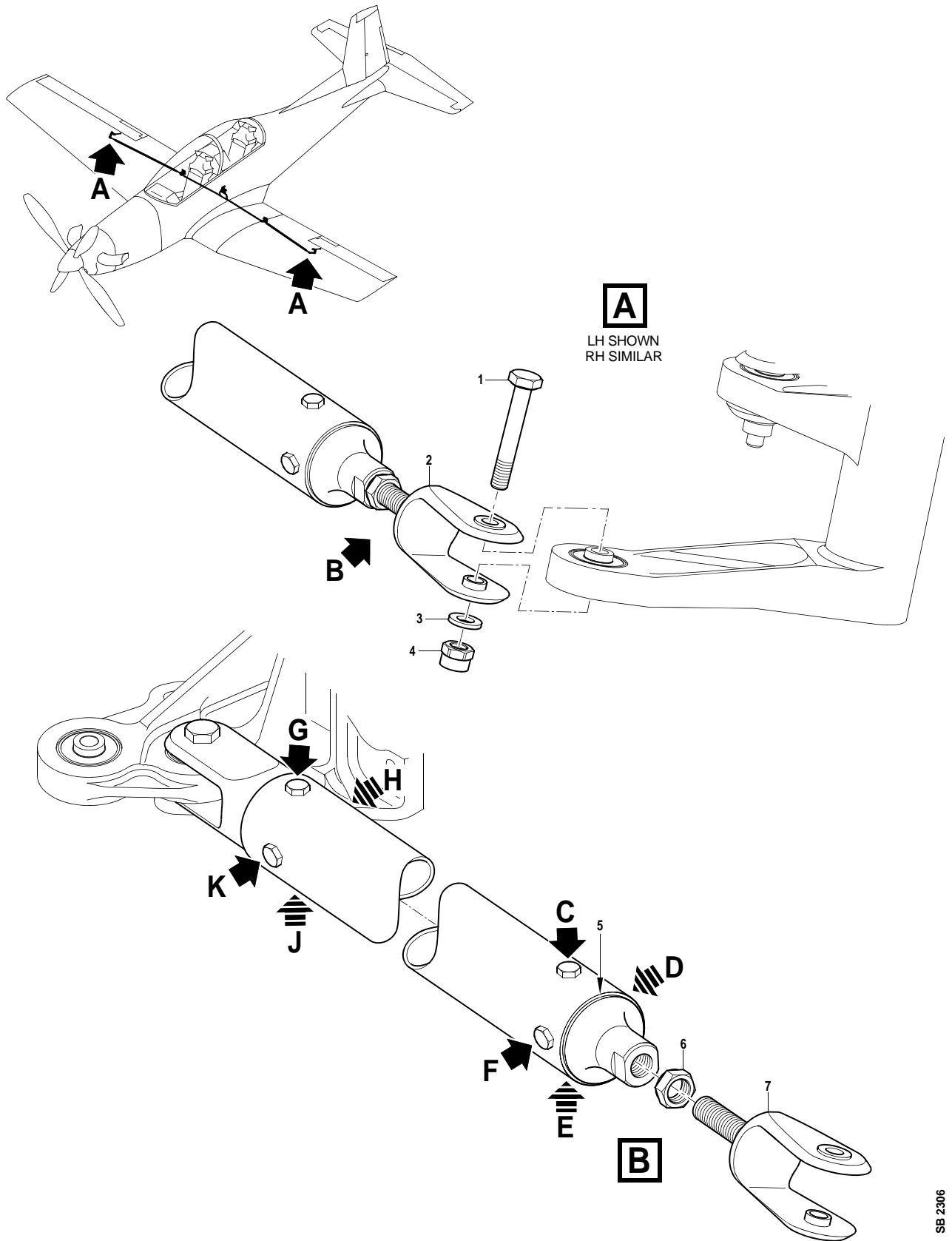

Aileron Outer Control-Rod - Inspection (If Necessary)
Figure 23

C

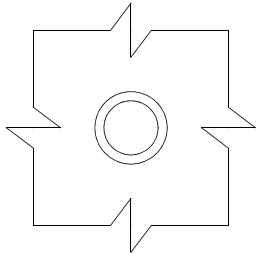

| | | | |
|----------------|---------------|---------------------|-----------|
| DATE: | AIRCRAFT MSN: | FLYING HOURS: | LANDINGS: |
| CRACK 1 LENGTH | mm | ADDITIONAL COMMENTS | |
| CRACK 2 LENGTH | mm | | |
| CRACK 3 LENGTH | mm | | |
| CRACK 4 LENGTH | mm | | |

D

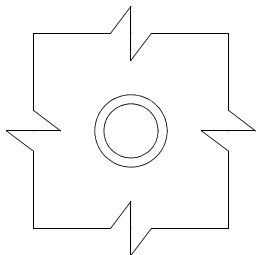

| | | | |
|----------------|---------------|---------------------|-----------|
| DATE: | AIRCRAFT MSN: | FLYING HOURS: | LANDINGS: |
| CRACK 1 LENGTH | mm | ADDITIONAL COMMENTS | |
| CRACK 2 LENGTH | mm | | |
| CRACK 3 LENGTH | mm | | |
| CRACK 4 LENGTH | mm | | |

E

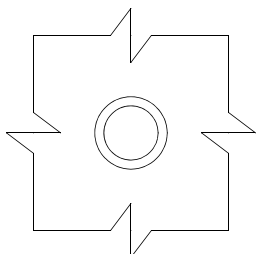

| | | | |
|----------------|---------------|---------------------|-----------|
| DATE: | AIRCRAFT MSN: | FLYING HOURS: | LANDINGS: |
| CRACK 1 LENGTH | mm | ADDITIONAL COMMENTS | |
| CRACK 2 LENGTH | mm | | |
| CRACK 3 LENGTH | mm | | |
| CRACK 4 LENGTH | mm | | |

F

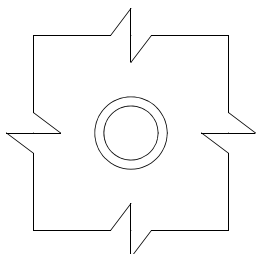

| | | | |
|----------------|---------------|---------------------|-----------|
| DATE: | AIRCRAFT MSN: | FLYING HOURS: | LANDINGS: |
| CRACK 1 LENGTH | mm | ADDITIONAL COMMENTS | |
| CRACK 2 LENGTH | mm | | |
| CRACK 3 LENGTH | mm | | |
| CRACK 4 LENGTH | mm | | |

SB 2307

Aileron Outer Control-Rod - Inspection Form
Figure 24, Sheet 1 of 2

G

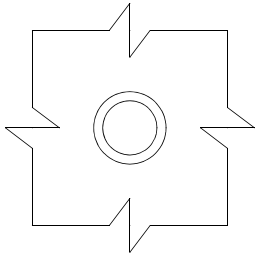

| | | | |
|----------------|---------------|---------------------|-----------|
| DATE: | AIRCRAFT MSN: | FLYING HOURS: | LANDINGS: |
| CRACK 1 LENGTH | mm | ADDITIONAL COMMENTS | |
| CRACK 2 LENGTH | mm | | |
| CRACK 3 LENGTH | mm | | |
| CRACK 4 LENGTH | mm | | |

H

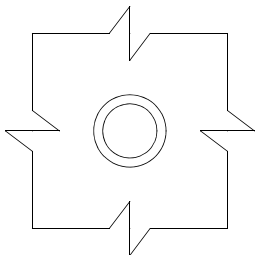

| | | | |
|----------------|---------------|---------------------|-----------|
| DATE: | AIRCRAFT MSN: | FLYING HOURS: | LANDINGS: |
| CRACK 1 LENGTH | mm | ADDITIONAL COMMENTS | |
| CRACK 2 LENGTH | mm | | |
| CRACK 3 LENGTH | mm | | |
| CRACK 4 LENGTH | mm | | |

J

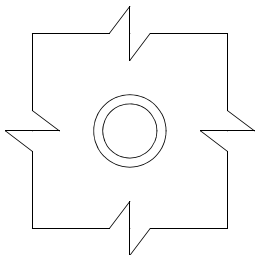

| | | | |
|----------------|---------------|---------------------|-----------|
| DATE: | AIRCRAFT MSN: | FLYING HOURS: | LANDINGS: |
| CRACK 1 LENGTH | mm | ADDITIONAL COMMENTS | |
| CRACK 2 LENGTH | mm | | |
| CRACK 3 LENGTH | mm | | |
| CRACK 4 LENGTH | mm | | |

K

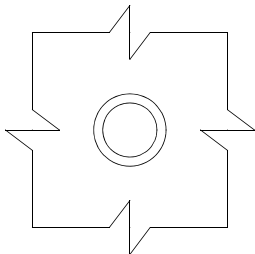

| | | | |
|----------------|---------------|---------------------|-----------|
| DATE: | AIRCRAFT MSN: | FLYING HOURS: | LANDINGS: |
| CRACK 1 LENGTH | mm | ADDITIONAL COMMENTS | |
| CRACK 2 LENGTH | mm | | |
| CRACK 3 LENGTH | mm | | |
| CRACK 4 LENGTH | mm | | |

(13) Inspection of the Front and Rear Rudder-Pedal Outboard-Bearings and, If Necessary, the Front and Rear Rudder-Pedal Outboard-Bearing Support-Plates

NOTE: Only personnel that are qualified and authorized by their designated Airworthiness Authorities are allowed to do this test.

NOTE: The front and rear rudder-pedal outboard-bearings are referred to as “the outboard bearings”.

NOTE: The front and rear rudder-pedal outboard-bearing support-plates are referred to as “the support plates”.

NOTE: All of the outboard bearings P/N 553.20.09.062 and P/N 553.20.09.231 are made from AA2024-T351.

(a) Do a check to identify which outboard bearings are installed:

1 If the outboard bearings looks the same as the one shown in sheet 1 of Fig. 25, it's part number is 553.20.09.062 or 553.20.09.231 and it is made from AA2024-T351, continue the Service Bulletin from Step 3.B.(13)(e).

2 If the outboard bearings looks the same as the one shown in sheet 2 of Fig. 25, it's P/N 553.20.09.235 and can be made from AA2024-T351 or AA2124-T851, continue the Service Bulletin from Step 3.B.(13)(b).

(b) Do the conductivity test to find the material of the outboard bearing (P/N 553.20.09.235) and the support plates (P/N 553.20.09.229).

NOTE: The outboard bearings (P/N 553.20.09.235) are attached to the support plate (P/N 553.20.09.229) (Ref. SRM, 53-20-00).

1 Remove the dirt and grease from the areas (where you will do the test) with the absorbent paper (Material No. P02-031) made moist with the solvent (Material No. P01-010).

NOTE: It is not necessary to remove the layers of surface protection (including paint) to do the test.

2 Do a check of the conductivity of the reference plates:

a Make sure the conductivity measurement equipment has been calibrated (Ref. Step at beginning of Para. 3.B.).

b Put the eddy current probe in position on the reference plates (P/N 513.57.09.149 and P/N 513.57.09.150).

c Record the value shown on the test equipment.

NOTE: The temperature of the outboard bearings (P/N 553.20.09.235) and the support plates (P/N 553.20.09.229) must be approximately the same as the reference plates (P/N 513.57.09.149 and P/N 513.57.09.150) (Ref. Step at beginning of Para. 3.B.).

- 3 Put the eddy current probe in position on one of the outboard bearings (P/N 553.20.09.235).
 - 4 Record the value shown on the test equipment.
 - 5 Compare the value recorded above with the values recorded in Step 3.B.(13)(b)2c and determine if the outboard bearing is manufactured from AA2024-T351 or AA2124-T851.
 - 6 Do Steps 3.B(13)(b)3 thru 5 again to make sure the result is the same.
 - 7 If necessary, do Step 3.B.(13)(b)3 thru 6 again on the remaining three outboard bearings (P/N 553.20.09.235).
 - 8 Write the type of material that the outboard bearings (P/N 553.20.09.235) are made from on the Status of Parts Form (Ref. Fig. 29).
 - 9 Put the eddy current probe in position on one of the support plates (P/N 553.20.09.229).
 - 10 Record the value shown on the test equipment.
 - 11 Compare the value recorded above with the values recorded in Step 3.B.(13)(b)2c and determine if the support plate is manufactured from AA2024-T351 or AA2124-T851.
 - 12 Do Steps 3.B(13)(b)9 thru 11 again to make sure the result is the same.
 - 13 If necessary, do Step 3.B.(13)(b)9 thru 12 again on the remaining three support plates (P/N 553.20.09.229).
 - 14 Write the type of material that the support plates (P/N 553.20.09.229) are made from on the Status of Parts Form (Ref. Fig. 29).
- (c) If you have outboard bearings P/N 553.20.09.062 or P/N 553.20.09.231 installed or if you find an outboard bearing (P/N 553.20.09.235) made from AA2024-T351, continue this Service Bulletin from Step 3.B.(13)(f).
- (d) If you have a support plate (P/N 553.20.09.229) made from AA2024-T351, continue this Service Bulletin from Step 3.B.(13)(i).
- (e) If the outboard bearings (P/N 553.20.09.235) and the support plates (P/N 553.20.09.229) are made from AA2124-T851, re-identify them (Ref. Para. 2.D.) and continue this Service Bulletin from Step 3.C.

- (f) Do an inspection for cracks of the outboard bearings (Ref. Fig. 25):

NOTE: Step 3.B.(13)(f) is applicable to:

- Outboard bearings (P/N 553.20.09.062 and P/N 553.20.09.231)
- Outboard bearings (P/N 553.20.09.235) made from AA2024-T351.

NOTE: Only personnel that are qualified and authorized by their designated Airworthiness Authorities are allowed to do this test.

NOTE: The outboard bearings (P/N 553.20.09.062) are attached to the support plate (P/N 553.20.09.063) (Ref. SRM, 53-20-00).

NOTE: The outboard bearings (P/N 553.20.09.231) are attached to the support plate (P/N 553.20.09.232) (Ref. SRM, 53-20-00).

NOTE: The outboard bearings (P/N 553.20.09.235) are attached to the support plate (P/N 553.20.09.229) (Ref. SRM, 53-20-00).

1 If necessary, remove the insulation material from the outboard bearings (P/N 553.20.09.062, P/N 553.20.09.231 or P/N 553.20.09.235) (Ref. SRM, 53-10-00, Page Block 201).

2 Use the absorbent paper (Material No. P02-031) made moist with the solvent (Material No. P01-010) and remove the dirt and grease from the inspection areas of the outboard bearings (P/N 553.20.09.062, P/N 553.20.09.231 or P/N 553.20.09.235).

NOTE: It is not necessary to remove the layers of surface protection to do the inspection.

3 Obey the manufacturer's instructions and use a boroscope to examine the inspection areas of the outboard bearings (P/N 553.20.09.062, P/N 553.20.09.231 or P/N 553.20.09.235) for cracks.

4 If you find cracks:

a You must contact Pilatus Customer Support before next flight. The address is:

PILATUS AIRCRAFT LTD.,
Customer Technical Support (MCC),
P.O. Box 992
6371 Stans, Switzerland

Fax: + 41 (0) 41 619 67 73
Email: Techsupport@pilatus-aircraft.com.

b Make a report of the inspection results, refer to Step 3.B(13)(h).

- (g) If you do not find cracks, make a report of the inspection results, refer Step 3.B.(13)(h).

(h) Report the Inspection Results

- 1 Make a copy of the Inspection Report Form(s) (Ref. Fig. 26).
- 2 Complete the Inspection Report Form:
 - Give the date of the inspection.
 - Give the aircraft details.
 - Show the location(s) and dimensions of the crack(s) found (if applicable).
 - Add any necessary comments.

NOTE: If there are no crack indications, the Inspection Report Form is used to tell Pilatus Aircraft Ltd. the aircraft details.

- 3 Send or fax the completed form(s) to:

Pilatus Aircraft Ltd.
Customer Technical Support (MCC)
P.O.Box 992
6371 Stans, Switzerland

Fax No. + 41 (0) 41 619 67 73.
Email: Techsupport@pilatus-aircraft.com.

(i) Do an inspection for cracks of the support plates (Ref. Fig. 27):

NOTE: Step 3.B.(13)(i) is applicable to support plates (P/N 553.20.09.229) made from AA2024-T351.

NOTE: Only personnel that are qualified and authorized by their designated Airworthiness Authorities are allowed to do this test.

- 1 If necessary, remove the insulation material (Ref. SRM, 53-10-00, Page Block 201) from the support plates (P/N 553.20.09.229).
- 2 Use the absorbent paper (Material No. P02-031) made moist with the solvent (Material No. P01-010) and remove the dirt and grease from the inspection areas of the support plates (P/N 553.20.09.229).

NOTE: It is not necessary to remove the layers of surface protection to do the inspection.

- 3 Obey the manufacturer's instructions and use a boroscope to examine the inspection areas of the support plates (P/N 553.20.09.229) for cracks.

4 If you find cracks:

- a You must contact Pilatus Customer Support before next flight. The address is:

PILATUS AIRCRAFT LTD.,
Customer Technical Support (MCC),
P.O. Box 992
6371 Stans, Switzerland

Fax: + 41 (0) 41 619 67 73
Email: Techsupport@pilatus-aircraft.com.

- b Make a report of the inspection results, refer to Step 3.B(13)(k).

- (j) If you do not find cracks, make a report of the inspection results, refer Step 3.B.(13)(k).

- (k) Report the Inspection Results

1 Make a copy of the Inspection Report Form(s) (Ref. Fig. 28).

2 Complete the Inspection Report Form:

- Give the date of the inspection.
- Give the aircraft details.
- Show the location(s) and dimensions of the crack(s) found (if applicable).
- Add any necessary comments.

NOTE: If there are no crack indications, the Inspection Report Form is used to tell Pilatus Aircraft Ltd. the aircraft details.

3 Send or fax the completed form(s) to:

Pilatus Aircraft Ltd.
Customer Technical Support (MCC)
P.O.Box 992
6371 Stans, Switzerland

Fax No. + 41 (0) 41 619 67 73.
Email: Techsupport@pilatus-aircraft.com.

- (l) If removed, install the insulation material (Ref. SRM, 53-10-00, Page Block 201) on:

- The outboard bearings (P/N 553.20.09.062, P/N 553.20.09.231 or P/N 553.20.09.235)
- The support plates (P/N 553.20.09.229).

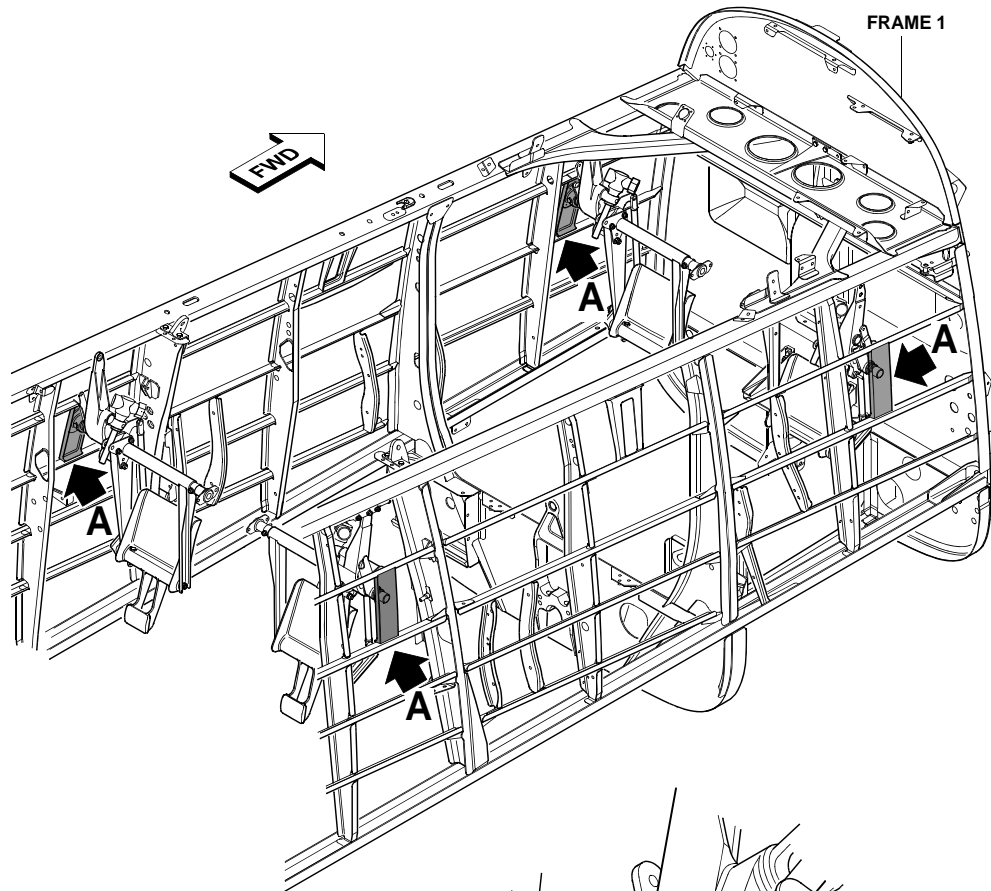

FRAME 1

FWD

NOTE:
TYPICAL OLDER TYPE
OUTBOARD RUDDER
SUPPORT BEARING SHOWN.
QUANTITY OF RIVETS CAN
BE DIFFERENT. REFER
TO INSPECTION FORMS.

INSPECTION AREA

TYPICAL CRACK AROUND
RIVET HOLE



FWD LH SHOWN

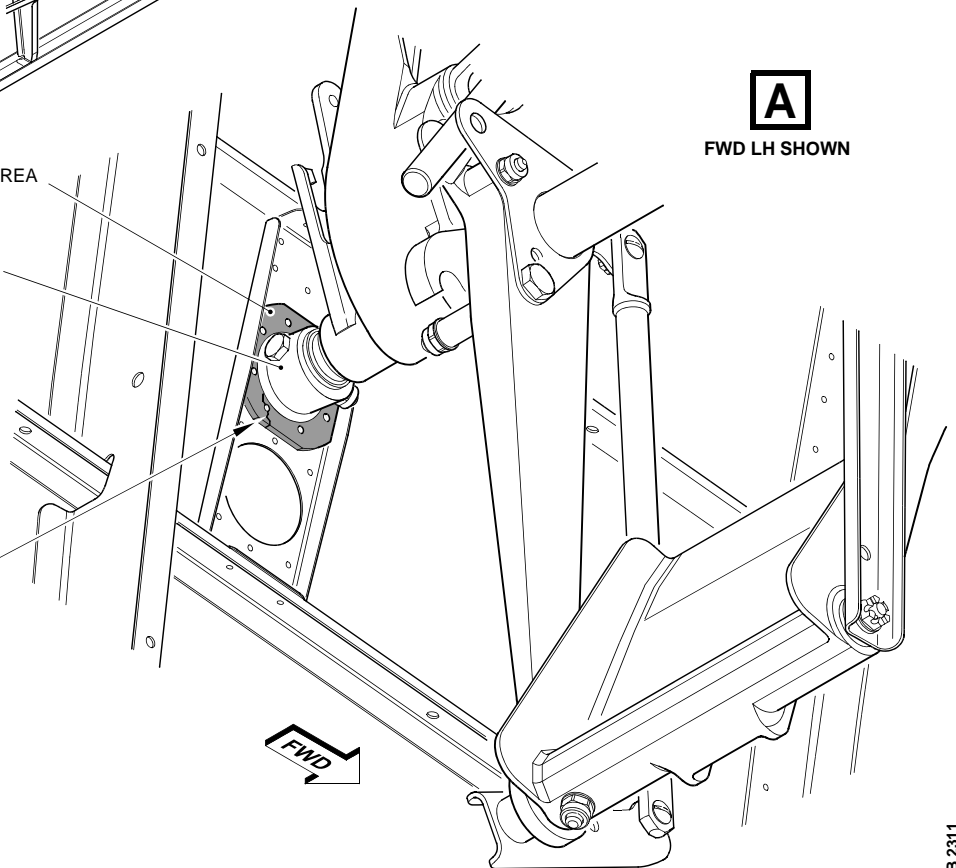

FWD

SB 2311

Front and Rear Rudder-Pedal Outboard-Bearings (P/N 553.20.09.062 / 231) - Inspection (If Necessary)
Figure 25, Sheet 1 of 2

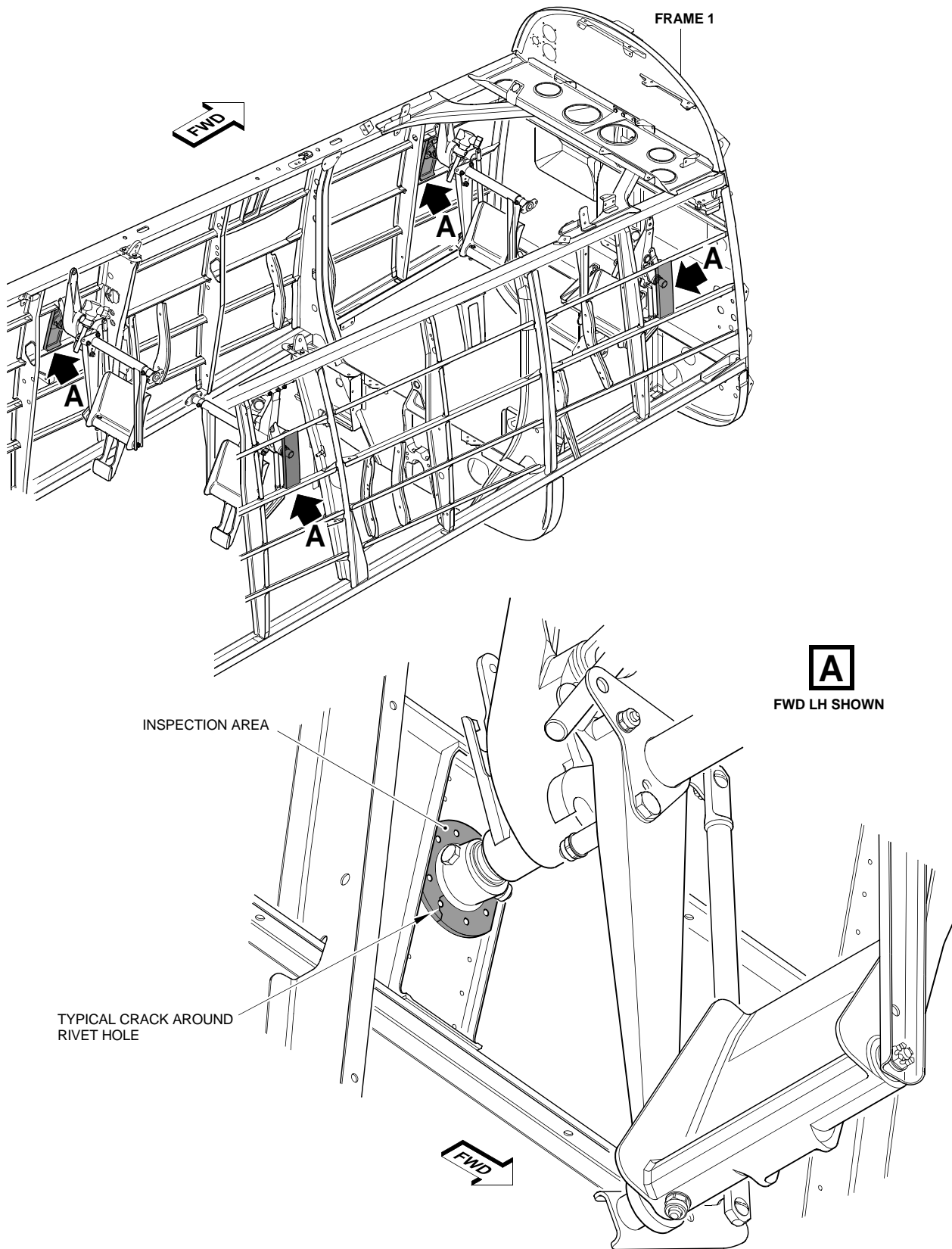

Front and Rear Rudder-Pedal Outboard-Bearings (P/N 553.20.09.235) - Inspection (If Necessary)
Figure 25, Sheet 2 of 2

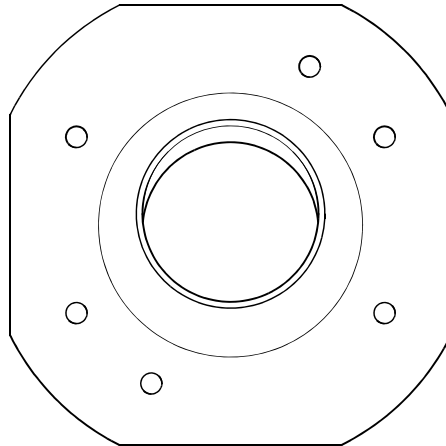

FWD LH SUPPORT BRACKET

| | | | |
|----------------|---------------|---------------------|-----------|
| DATE: | AIRCRAFT MSN: | FLYING HOURS: | LANDINGS: |
| CRACK 1 LENGTH | mm | ADDITIONAL COMMENTS | |
| CRACK 2 LENGTH | mm | | |
| CRACK 3 LENGTH | mm | | |
| CRACK 4 LENGTH | mm | | |

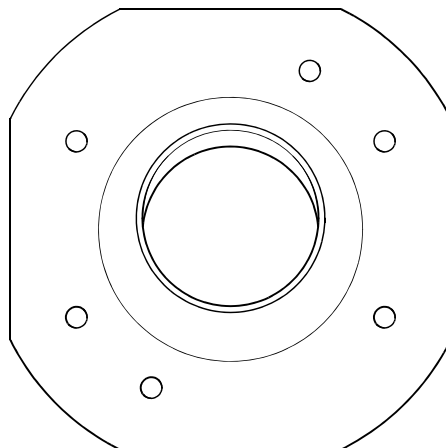

FWD RH SUPPORT BRACKET

| | | | |
|----------------|---------------|---------------------|-----------|
| DATE: | AIRCRAFT MSN: | FLYING HOURS: | LANDINGS: |
| CRACK 1 LENGTH | mm | ADDITIONAL COMMENTS | |
| CRACK 2 LENGTH | mm | | |
| CRACK 3 LENGTH | mm | | |
| CRACK 4 LENGTH | mm | | |

SB 2289

Front and Rear Rudder-Pedal Outboard-Bearings (P/N 553.20.09.062) - Inspection Form
Figure 26, Sheet 1 of 6

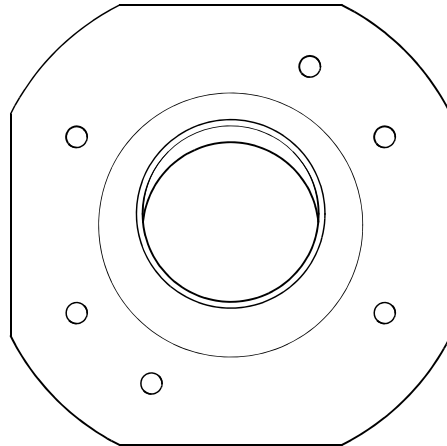

REAR LH SUPPORT BRACKET

| | | | | | | | |
|----------------|----|---------------------|--|---------------|--|-----------|--|
| DATE: | | AIRCRAFT MSN: | | FLYING HOURS: | | LANDINGS: | |
| CRACK 1 LENGTH | mm | ADDITIONAL COMMENTS | | | | | |
| CRACK 2 LENGTH | mm | | | | | | |
| CRACK 3 LENGTH | mm | | | | | | |
| CRACK 4 LENGTH | mm | | | | | | |

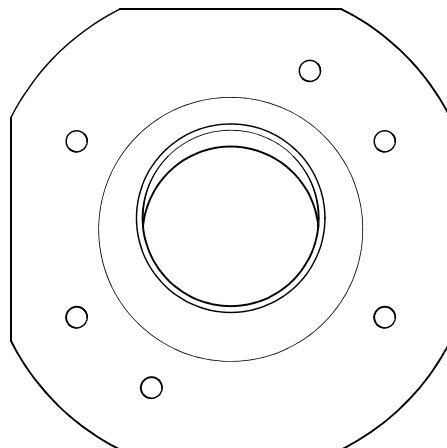

REAR RH SUPPORT BRACKET

| | | | | | | | |
|----------------|----|---------------------|--|---------------|--|-----------|--|
| DATE: | | AIRCRAFT MSN: | | FLYING HOURS: | | LANDINGS: | |
| CRACK 1 LENGTH | mm | ADDITIONAL COMMENTS | | | | | |
| CRACK 2 LENGTH | mm | | | | | | |
| CRACK 3 LENGTH | mm | | | | | | |
| CRACK 4 LENGTH | mm | | | | | | |

SB 2290

Front and Rear Rudder-Pedal Outboard-Bearings (P/N 553.20.09.062) - Inspection Form
Figure 26, Sheet 2 of 6

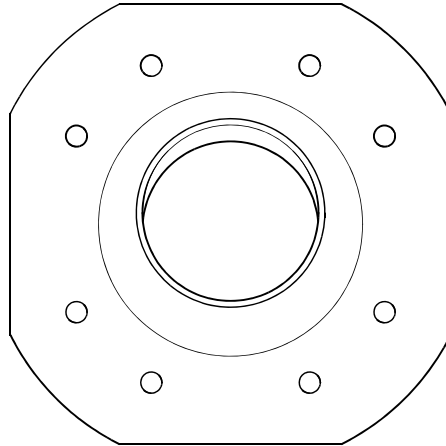

FWD LH SUPPORT BRACKET

| DATE: | AIRCRAFT MSN: | FLYING HOURS: | LANDINGS: |
|----------------|---------------|---------------------|-----------|
| CRACK 1 LENGTH | mm | ADDITIONAL COMMENTS | |
| CRACK 2 LENGTH | mm | | |
| CRACK 3 LENGTH | mm | | |
| CRACK 4 LENGTH | mm | | |

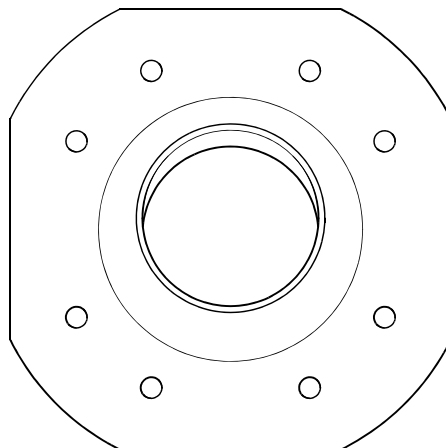

FWD RH SUPPORT BRACKET

| DATE: | AIRCRAFT MSN: | FLYING HOURS: | LANDINGS: |
|----------------|---------------|---------------------|-----------|
| CRACK 1 LENGTH | mm | ADDITIONAL COMMENTS | |
| CRACK 2 LENGTH | mm | | |
| CRACK 3 LENGTH | mm | | |
| CRACK 4 LENGTH | mm | | |

SB 2287

Front and Rear Rudder-Pedal Outboard-Bearings (P/N 553.20.09.231) - Inspection Form
Figure 26, Sheet 3 of 6

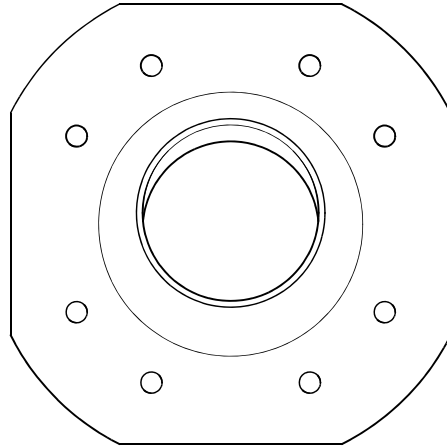

REAR LH SUPPORT BRACKET

| | | | |
|----------------|---------------|---------------------|-----------|
| DATE: | AIRCRAFT MSN: | FLYING HOURS: | LANDINGS: |
| CRACK 1 LENGTH | mm | ADDITIONAL COMMENTS | |
| CRACK 2 LENGTH | mm | | |
| CRACK 3 LENGTH | mm | | |
| CRACK 4 LENGTH | mm | | |

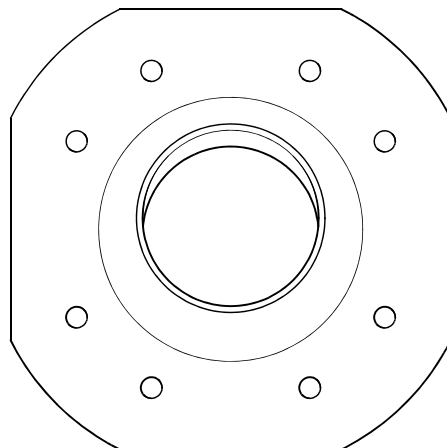

REAR RH SUPPORT BRACKET

| | | | |
|----------------|---------------|---------------------|-----------|
| DATE: | AIRCRAFT MSN: | FLYING HOURS: | LANDINGS: |
| CRACK 1 LENGTH | mm | ADDITIONAL COMMENTS | |
| CRACK 2 LENGTH | mm | | |
| CRACK 3 LENGTH | mm | | |
| CRACK 4 LENGTH | mm | | |

SB 2288

Front and Rear Rudder-Pedal Outboard-Bearings (P/N 553.20.09.231) - Inspection Form
Figure 26, Sheet 4 of 6

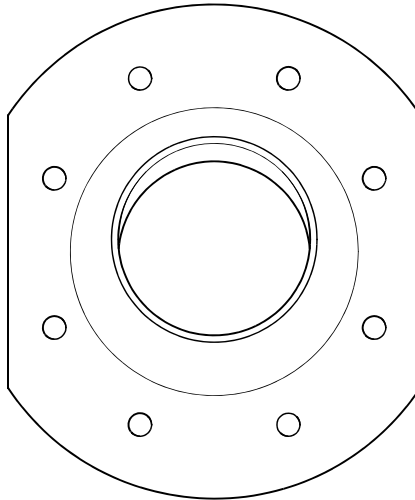

FWD LH SUPPORT BRACKET

| | | | |
|----------------|---------------|---------------------|-----------|
| DATE: | AIRCRAFT MSN: | FLYING HOURS: | LANDINGS: |
| CRACK 1 LENGTH | mm | ADDITIONAL COMMENTS | |
| CRACK 2 LENGTH | mm | | |
| CRACK 3 LENGTH | mm | | |
| CRACK 4 LENGTH | mm | | |

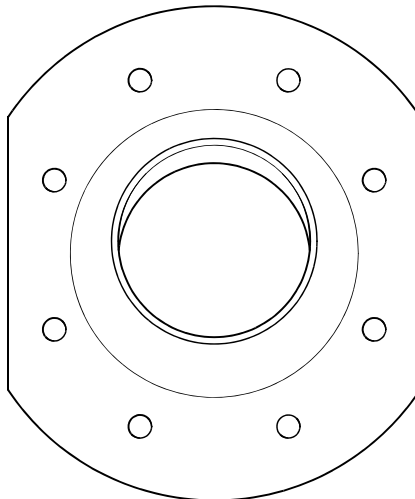

FWD RH SUPPORT BRACKET

| | | | |
|----------------|---------------|---------------------|-----------|
| DATE: | AIRCRAFT MSN: | FLYING HOURS: | LANDINGS: |
| CRACK 1 LENGTH | mm | ADDITIONAL COMMENTS | |
| CRACK 2 LENGTH | mm | | |
| CRACK 3 LENGTH | mm | | |
| CRACK 4 LENGTH | mm | | |

Front and Rear Rudder-Pedal Outboard-Bearings (P/N 553.20.09.235) - Inspection Form
Figure 26, Sheet 5 of 6

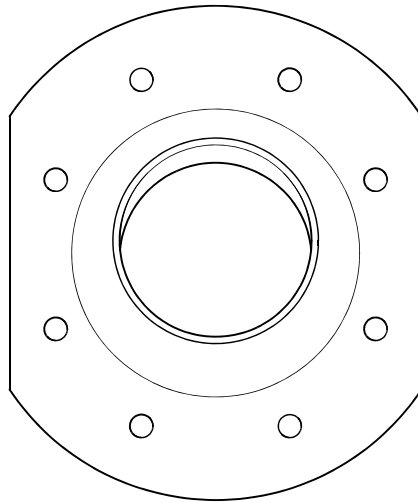

REAR LH SUPPORT BRACKET

| | | | | |
|----------------|----|---------------------|---------------|-----------|
| DATE: | | AIRCRAFT MSN: | FLYING HOURS: | LANDINGS: |
| CRACK 1 LENGTH | mm | ADDITIONAL COMMENTS | | |
| CRACK 2 LENGTH | mm | | | |
| CRACK 3 LENGTH | mm | | | |
| CRACK 4 LENGTH | mm | | | |

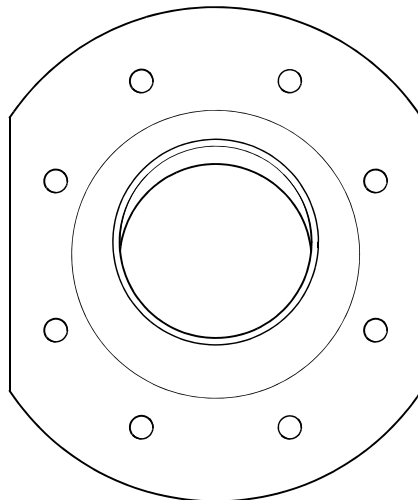

REAR RH SUPPORT BRACKET

| | | | | |
|----------------|----|---------------------|---------------|-----------|
| DATE: | | AIRCRAFT MSN: | FLYING HOURS: | LANDINGS: |
| CRACK 1 LENGTH | mm | ADDITIONAL COMMENTS | | |
| CRACK 2 LENGTH | mm | | | |
| CRACK 3 LENGTH | mm | | | |
| CRACK 4 LENGTH | mm | | | |

SB 2292

Front and Rear Rudder-Pedal Outboard-Bearings (P/N 553.20.09.235) - Inspection Form
Figure 26, Sheet 6 of 6

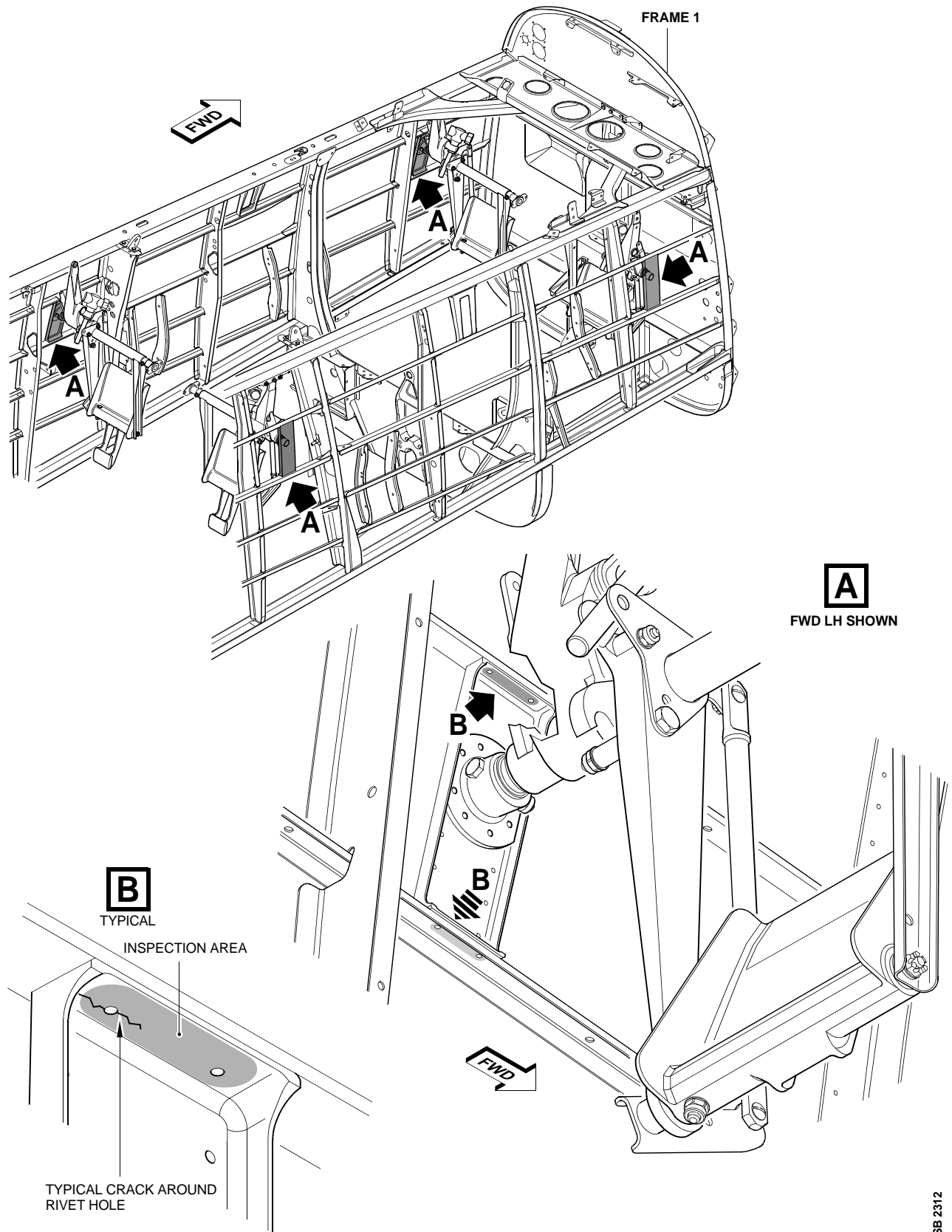

Front and Rear Rudder-Pedal Outboard-Bearing-Support Plates (P/N 553.20.09.229) - Inspection
Figure 27

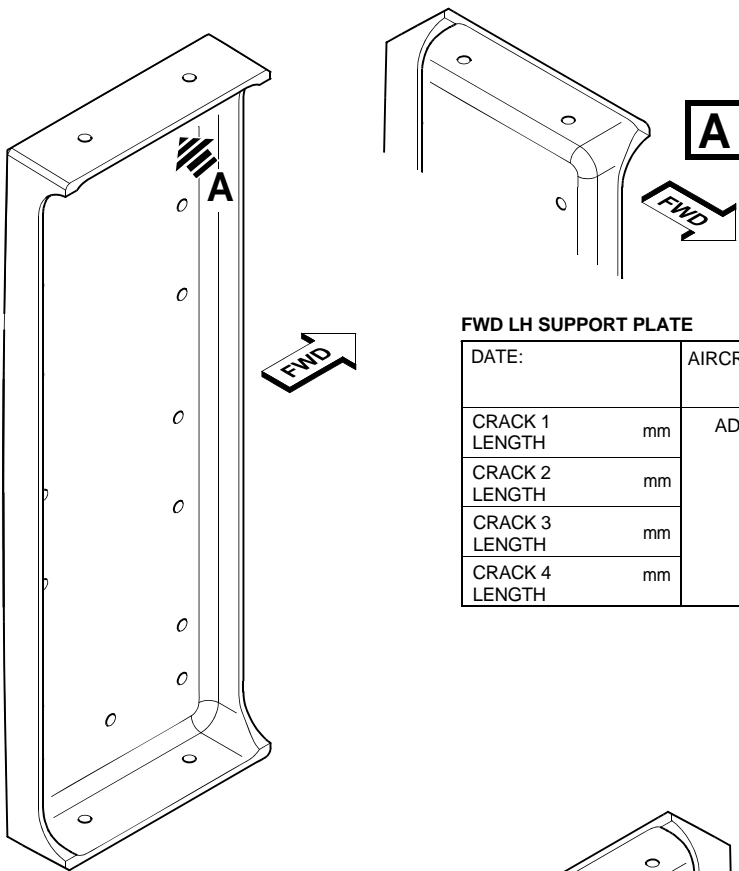

FWD LH SUPPORT PLATE

| DATE: | AIRCRAFT MSN: | FLYING HOURS: | LANDINGS: |
|----------------|---------------|---------------------|-----------|
| CRACK 1 LENGTH | mm | ADDITIONAL COMMENTS | |
| CRACK 2 LENGTH | mm | | |
| CRACK 3 LENGTH | mm | | |
| CRACK 4 LENGTH | mm | | |

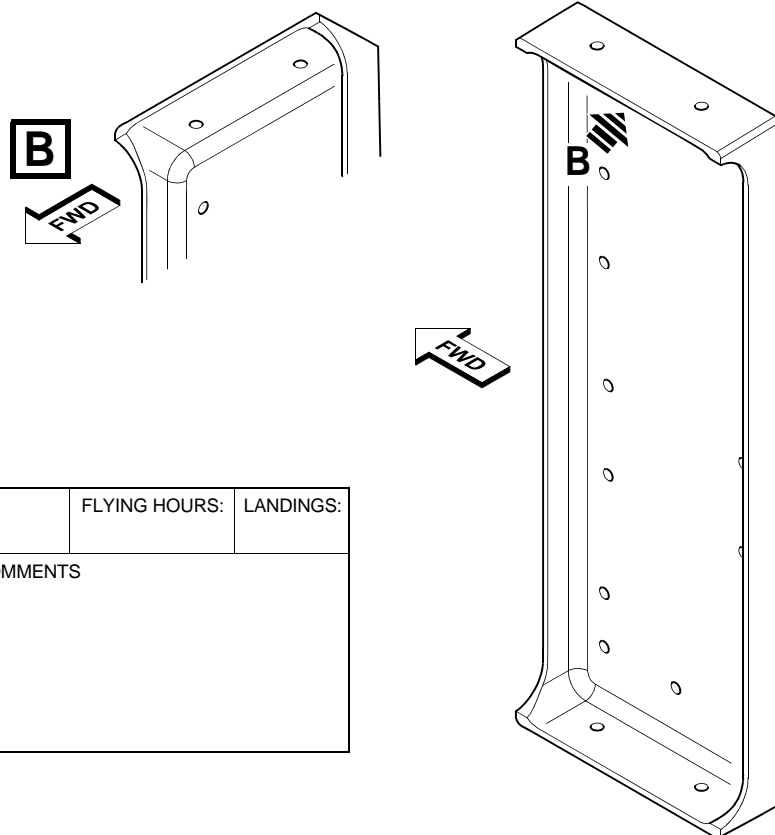

FWD RH SUPPORT PLATE

| DATE: | AIRCRAFT MSN: | FLYING HOURS: | LANDINGS: |
|----------------|---------------|---------------------|-----------|
| CRACK 1 LENGTH | mm | ADDITIONAL COMMENTS | |
| CRACK 2 LENGTH | mm | | |
| CRACK 3 LENGTH | mm | | |
| CRACK 4 LENGTH | mm | | |

SB 2313

Front and Rear Rudder-Pedal Outboard-Bearing-Support Plates (P/N 553.20.09.229) - Inspection Form
Figure 28, Sheet 1 of 2

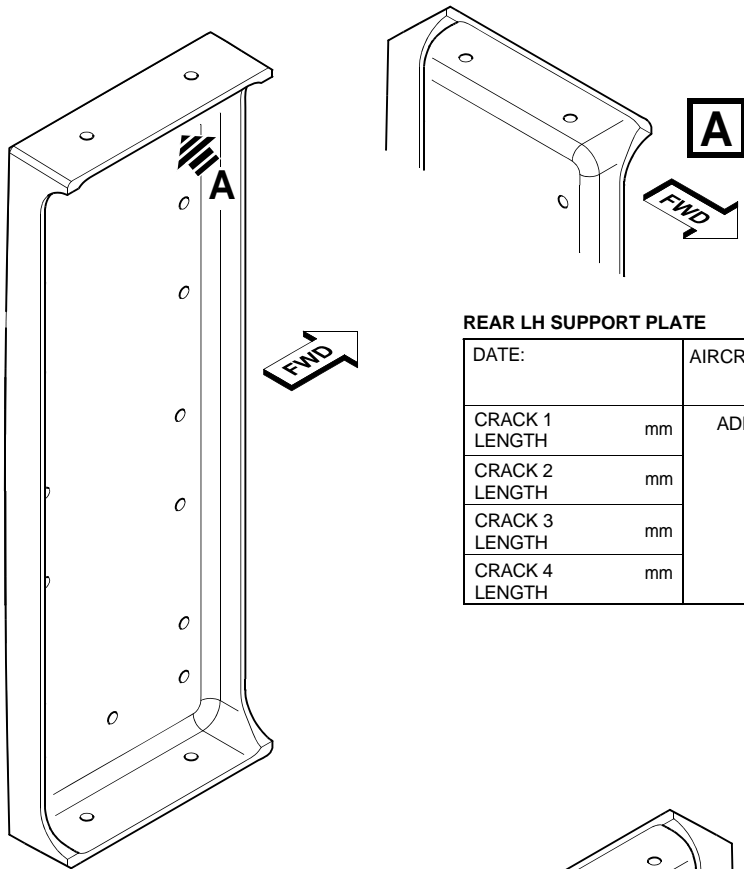

REAR LH SUPPORT PLATE

| DATE: | AIRCRAFT MSN: | FLYING HOURS: | LANDINGS: |
|----------------|---------------|---------------------|-----------|
| CRACK 1 LENGTH | mm | ADDITIONAL COMMENTS | |
| CRACK 2 LENGTH | mm | | |
| CRACK 3 LENGTH | mm | | |
| CRACK 4 LENGTH | mm | | |

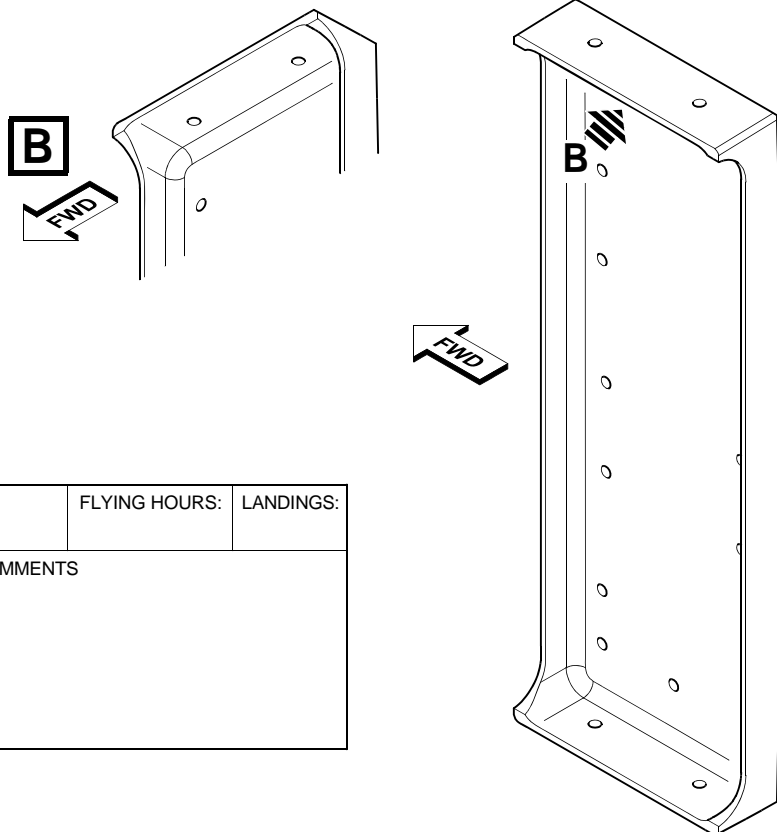

REAR RH SUPPORT PLATE

| DATE: | AIRCRAFT MSN: | FLYING HOURS: | LANDINGS: |
|----------------|---------------|---------------------|-----------|
| CRACK 1 LENGTH | mm | ADDITIONAL COMMENTS | |
| CRACK 2 LENGTH | mm | | |
| CRACK 3 LENGTH | mm | | |
| CRACK 4 LENGTH | mm | | |

SB 2314

Front and Rear Rudder-Pedal Outboard-Bearing-Support Plates (P/N 553.20.09.229) - Inspection Form
Figure 28, Sheet 2 of 2

INTENTIONALLY BLANK

| Item | Name | Part Number before accomplishment of this Service Bulletin | Material, after accomplishment of this Service Bulletin | Part Number, after accomplishment of this Service Bulletin |
|------|---|---|---|--|
| 1 | AILERON NOSE RIB 1, LH | 557.51.09.013 | | |
| 2 | AILERON NOSE RIB 1, RH | 557.51.09.014 | | |
| 3 | ELEVATOR CENTER-ATTACHMENT BEARING-BRACKET | 555.10.09.060 * or 555.10.09.143 * | | |
| 4 | RUDDER LOWER-HINGE BEARING-BRACKET | 555.30.09.039 | | |
| 5 | FRAME 3 PICK-UP BRACKET, LH | 553.10.09.075 | | |
| 6 | FRAME 3 PICK-UP BRACKET, RH | 553.10.09.076 | | |
| 7 | FLAP BEARING SUPPORT BRACKET, LH | 111.34.07.329 | | |
| 8 | FLAP BEARING SUPPORT BRACKET, RH | 111.34.07.330 | | |
| 9 | REAR CONTROL-COLUMN SUPPORT-BEARING BRACKET | 557.31.09.142 * or 557.31.09.353 * | | |
| 10 | LEVER | 527.30.09.027 | | |
| 11 | BEARING | 527.30.09.029 | | |
| 12 | SHACKLE | 527.30.09.036 | | |
| 13 | SHACKLE | 116.35.07.092 | | |
| 14 | LEFT AILERON OUTER CONTROL-ROD | 527.10.09.021 * or 527.10.09.073 * | | |
| 15 | RIGHT AILERON OUTER CONTROL-ROD | 527.10.09.021 * or 527.10.09.073 * | | |
| 16 | ELEVATOR CENTER CONTROL-ROD | 527.30.09.015 * or 527.30.09.082 * | | |
| 17 | ELEVATOR REAR CONTROL-ROD | 527.30.09.016 * or 527.30.09.083 * | | |
| 18 | FRONT LEFT RUDDER-PEDAL OUTBOARD BEARINGS | 553.20.09.062 * or 553.20.09.231 * or 553.20.09.235 * | | |

Aircraft Tail No.

 Status of Parts Form
 Figure 29, Sheet 1 of 2

| Item | Name | Part Number before accomplishment of this Service Bulletin | Material, after accomplishment of this Service Bulletin | Part Number, after accomplishment of this Service Bulletin |
|------|---|---|---|--|
| 19 | FRONT RIGHT RUDDER-PEDAL OUTBOARD BEARINGS | 553.20.09.062 * or 553.20.09.231 * or 553.20.09.235 * | | |
| 20 | REAR LEFT RUDDER-PEDAL OUTBOARD BEARINGS | 553.20.09.062 * or 553.20.09.231 * or 553.20.09.235 * | | |
| 21 | REAR RIGHT RUDDER-PEDAL OUTBOARD BEARINGS | 553.20.09.062 * or 553.20.09.231 * or 553.20.09.235 * | | |
| 22 | FRONT LEFT RUDDER-PEDAL OUTBOARD-BEARING SUPPORT-PLATE | 553.20.09.063 * or 553.20.09.232 * or 553.20.09.229 * | | |
| 23 | FRONT RIGHT RUDDER-PEDAL OUTBOARD-BEARING SUPPORT-PLATE | 553.20.09.063 * or 553.20.09.232 * or 553.20.09.229 * | | |
| 24 | REAR LEFT RUDDER-PEDAL OUTBOARD-BEARING SUPPORT-PLATE | 553.20.09.063 * or 553.20.09.232 * or 553.20.09.229 * | | |
| 25 | REAR RIGHT RUDDER-PEDAL OUTBOARD-BEARING SUPPORT-PLATE | 553.20.09.063 * or 553.20.09.232 * or 553.20.09.229 * | | |

Note: * - Delete part numbers that do not apply.

Aircraft Tail No.

 Status of Parts Form
 Figure 29, Sheet 2 of 2

C. Close-Up

- (1) Remove all the equipment, tools and materials from the work area. Make sure that the work area is clean.
- (2) If removed, install the balance weights (Ref. AMM, 08-10-01, Page Block 401).
- (3) Install the flight control covers in the rear cockpit (Ref. Fig. 2):
 - (a) Put the bottom cover (6) in position.
 - (b) Put the lower shroud (5) in position.
 - (c) Put the upper shroud (2) in position.
 - (d) Install the screws (3) and the washers (4) in the upper shroud (2) and the lower shroud (5).
 - (e) Put the top cover (1) in position.
 - (f) Install the screws (8) and the washers (7) in the top cover (1) and the bottom cover (6).
 - (g) Install the screws (9) and the washers (10) in the top cover (1).
 - (h) Connect the electrical connector, then install the screw, the washer and the P clip (Ref. AMM, 27-05-02, Page Block 401 for more information).
 - (i) Put the leather collar in position and install the worm-drive clamp (Ref. AMM, 27-05-02, Page Block 401 for more information).
- (4) Install the left and right floor panels from the rear cockpit that you removed to get access to the left and right frame 3 pick-up brackets (Ref. IPC, 25-10-01 for more information).
- (5) Install the flight control covers in the front cockpit (Ref. Fig. 1):
 - (a) Put the shroud (1) in position.
 - (b) Install the screws (6) and the washers (5).
 - (c) Put the forward cover (2) in position.
 - (d) Install the screws (3) and the washers (4).
 - (e) Connect the electrical connector, then install the screw, the washer and the P clip (Ref. AMM, 27-05-02, Page Block 401 for more information).
 - (f) Put the leather collar in position and install the worm-drive clamp (Ref. AMM, 27-05-02, Page Block 401 for more information).
- (6) Install the left and right side panels from the front and rear cockpits that you removed to get access to the left and right rudder pedals outboard support-bearings (Ref. AMM, 25-30-02, Page Block 401).
- (7) Install the left and right side panels from the front cockpit that you removed to get access to the left and right frame 3 pick-up brackets (Ref. AMM, 25-30-02, Page Block 401).

- (8) Connect the battery mating connector.
- (9) If necessary, safety the battery mating connector with the lockwire (Material No. P02-001).
- (10) Connect the battery hot plug P202.
- (11) In the front cockpit, remove the safety clip and close the circuit breaker:

BAT SWITCH (BATTERY BUS CB panel).
- (12) Install the front and rear ejection seats (Ref. AMM, 25-10-01, Page Block 401).
- (13) Remove the ballast from the tail mooring point (Ref. AMM, 07-10-00, Page Block 201).
- (14) Remove the tail jack and the adapter (Ref. AMM, 07-10-00, Page Block 201).
- (15) Engage the flight control lock.
- (16) Remove the warning signs (DO NOT OPERATE THE FLIGHT CONTROLS) from the front and rear cockpits.

NOTE: For the location of the access items, refer to AMM, 06-20-00, Page Block 1 or 12-00-00, Page Block 1.
- (17) Close the access panel F8.
- (18) Install the access panels F12, F13, F14, LB5, RB5, LT9 and RT9.

D. Documentation

- (1) Make an entry in the Aircraft Logbook that this Service Bulletin has been incorporated.
- (2) Use the Service Bulletin Evaluation Sheet and report your results and the serial number(s) of the aircraft to Pilatus.
- (3) Put the Status of Parts Form (Ref. Fig 29) in the Aircraft Logbook.

NOTE: If the parts are made from AA2024-T351 but have no cracks, you will need to do repetitive inspections (Ref. AMM, Chapter 05). You will need this Form (Ref. Fig. 29) to tell you which parts require the inspection.

4. Accomplishment Instructions - Equipment Held as Spare or in Stock

NOTE: This procedure is applicable to all of the parts listed below, held as spare or in stock:

| PART NUMBER | DESCRIPTION |
|---|---|
| 557.51.09.013 or 557.51.09.101 | AILERON NOSE RIB 1, LH or AILERON NOSE RIB 1 ASSY, LH |
| 557.51.09.014 or 557.51.09.102 | AILERON NOSE RIB 1, RH or AILERON NOSE RIB 1 ASSY, RH |
| 555.10.09.060 or 555.10.09.059 | ELEVATOR CENTER-ATTACHMENT BEARING-BRACKET or ELEVATOR CENTER-ATTACHMENT BEARING-BRACKET ASSY |
| 555.30.09.039 or 555.30.09.040 | RUDDER LOWER-HINGE BEARING-BRACKET or RUDDER LOWER-HINGE BEARING-BRACKET ASSY |
| 553.10.09.075 | FRAME 3 PICK-UP BRACKET, LH |
| 553.10.09.076 | FRAME 3 PICK-UP BRACKET, RH |
| 111.34.07.329 | FLAP BEARING SUPPORT BRACKET, LH |
| 111.34.07.330 | FLAP BEARING SUPPORT BRACKET, RH |
| 557.31.09.142 | REAR CONTROL-COLUMN SUPPORT-BEARING BRACKET |
| 527.30.09.027 | LEVER |
| 527.30.09.029 | BEARING |
| 527.30.09.036 | SHACKLE |
| 116.35.07.092 | SHACKLE |
| 527.10.09.021 | LEFT AND RIGHT AILERON OUTER CONTROL-ROD |
| 527.30.09.015 | ELEVATOR CENTER CONTROL-ROD |
| 527.30.09.016 | ELEVATOR REAR CONTROL-ROD |
| 553.20.09.062 or 553.20.09.231 or 553.20.09.235 | SEE NOTE SEE NOTE FRONT AND REAR RUDDER-PEDALS OUTBOARD-BEARINGS |

| PART NUMBER | DESCRIPTION |
|---------------|--|
| 553.20.09.229 | FRONT AND REAR RUDDER-PEDALS OUTBOARD-BEARING SUPPORT-PLATES |

NOTE: All Rudder-Pedal Outboard-Bearings, P/N 553.20.09.062 and P/N 553.20.09.231 are made from AA2024-T351. Send these parts to Pilatus Customer Support. Pilatus will send a replacement part made from AA2124-T851.

A. Preparation

- (1) Obey the manufacturer's operating instructions and calibrate the conductivity measurement equipment.
- (2) Put the eddy current probe in position on the reference plates (P/N 513.57.09.149 and P/N 513.57.09.150).
- (3) Record the value shown on the test equipment.
- (4) Make a note of the temperature of the reference plates (P/N 513.57.09.149 and P/N 513.57.09.150).

NOTE: The temperature of the reference plates (P/N 513.57.09.149 and P/N 513.57.09.150) must be approximately the same as the part to be checked.

B. Do the conductivity test to find the material

WARNING: BE CAREFUL WHEN YOU USE THE CONSUMABLE MATERIALS. OBEY THE MANUFACTURER'S HEALTH AND SAFETY INSTRUCTIONS.

NOTE: Only personnel that are qualified and authorized by their delegated Airworthiness Authorities are allowed to do this test.

- (1) If necessary, remove the grease from the areas of the part to be tested with the absorbent paper (Material No. P02-031) made moist with the solvent (Material No. P01-010).

NOTE: It is not necessary to remove the layers of surface protection (including paint) to do the test.

- (2) Put the eddy current probe in position on the part to be tested.
- (3) Record the value shown on the test equipment.
- (4) Compare the value recorded above with the values recorded in Section 4.A.(3) and determine if the part is made from AA2024-T351 or AA2124-T851.
- (5) Do Steps 4.B(1) thru (4) again to make sure the result is the same.
- (6) If the part is made from AA2024-T351, send it to Pilatus Customer Support. Pilatus will send a replacement part made from AA2124-T851.

- (7) If the part is made from AA2124-T851:
- Re-identify the part (Ref. Para. 2.D.) with a permanent marker pen (or equivalent)
 - Return the part to stores.

C. Documentation

- (1) Make an entry on the serviceable label (attached to the part) that this Service Bulletin has been accomplished.
- (2) Use the Service Bulletin Evaluation Sheet and report your results to Pilatus.

INTENTIONALLY BLANK

| SERVICE BULLETIN EVALUATION SHEET FOR SB No. 51-001 | | | |
|---|---|--------------------------|---------------------|
| Title | Aircraft Structure - General Do a Check of the Material Specification Used During Manufacture and, If Necessary, Do a Check for Cracks or Replace the Part | | |
| Customer | | | |
| Service Center | | | |
| EMBODIMENT REPORTING | | | |
| This SB has been embodied: | | <input type="checkbox"/> | On the entire fleet |
| | | <input type="checkbox"/> | Only partially |
| Provide embodiment details per aircraft (use additional copies of this table, if necessary) | | | |
| MSN | Flying Hours | MSN | Flying Hours |
| | | | |
| | | | |
| | | | |
| | | | |
| Additional embodiment comments/findings | | | |
| | | | |
| EDITORIAL COMMENTS (procedure, kit quality, suggested improvements, etc.) | | | |
| | | | |
| Name | Signature | Date | |
| | | | |
| Please complete and forward this form to: Pilatus Aircraft LTD, Customer Technical Support (MCC), P.O. BOX 992, 6371 Stans, Switzerland Fax: +41 (0)41 619 6773 Email: Techsupport@pilatus-aircraft.com | | | |

SERVICE BULLETIN EVALUATION SHEET

INTENTIONALLY BLANK