



PILATUS AIRCRAFT LTD. CH-6371 STANS, SWITZERLAND

SERVICE BULLETIN

SERVICE BULLETIN NO: 28-006

REF NO: IMCL

MODIFICATION NO: 010301

ATA CHAPTER: 28

FUEL - DISTRIBUTION ENGINE DRIVEN PUMP - TORQUE CHECK OF RELIEF-VALVE-BODY SCREWS

1. Planning Information

A. Effectivity

All PC-9 aircraft from MSN 001 and MSN 002, MSN 101 thru MSN 171, MSN 173 thru MSN 178, MSN 180 thru MSN 247 and MSN 501 thru MSN 567, with Engine Driven Pump (EDP) Vendor Part Number RG9570R1, PILATUS Part Number 968.84.51.106 installed. If the EDP has Vendor Part Number RG9570R1/M, this Service Bulletin is not necessary.

B. Concurrent Requirements

None.

C. Reason

(1) Problem

Fuel leakage through the gasket of the EDP relief valve.

(2) Cause

It is possible the torque of the screws that attach the EDP relief-valve cover to the relief valve housing is not correct. It is also possible that the gasket between the EDP relief-valve housing and the EDP housing has been pushed out.

(3) Solution

Do a check of the torque value of the EDP relief-valve-cover screws, inspect the EDP and replace if necessary.

D. Description

This Service Bulletin gives the data and instructions to do:

- A check of the EDP relief valve for fuel leakage and gasket material pushed out
- A check of the torque of the screws that attach the EDP relief-valve-cover to the relief valve housing.

E. Compliance

Mandatory.

Must be incorporated within the next 20 hours time-in-service (TIS) or 30 days after the effective date of this Service Bulletin whichever comes first.

DATE: Aug 10/01
REV No.

SERVICE BULLETIN No. 28-006
PAGE 1 of 5

PILATUS
PC9
SERVICE BULLETIN

F. Approval

The technical aspects of this Service Bulletin are approved by the Federal Office for Civil Aviation (FOCA) of Switzerland as an Airworthiness Directive.

NOTE: PILATUS advises Operators/Owners to check with their local Airworthiness Authorities for any changes, local regulations or sanctions that can affect the embodiment of this Service Bulletin.

G. Manpower

	Total	Total
Preparation	0.25	0.25
Torque Check (without EDP removal)	0.75	
Torque Check (with EDP removed)		1.50
Close up	0.25	0.25
TOTAL MAN-HOURS	1.25	2.00

NOTE: Man-hours figures do not include the time required to cure sealants and adhesives.

H. Weight and Balance

(1) Weight Change

Not affected.

(2) Moment Change

Not affected.

I. Electrical Load Data

Not changed.

J. Software

Not changed.

K. References

Aircraft Maintenance Manual (AMM), 12-00-00 and 28-20-10.

L. Publications Affected

Illustrated Parts Catalog (IPC), 28-20-01.

M. Interchangeability of Parts

Do not install an EDP PILATUS Part Number 968.84.51.106.

PILATUS
PC9
SERVICE BULLETIN

2. Material Information

A. Material - Price and Availability

Operators should send orders for Service Bulletin modification kits, to:

PILATUS AIRCRAFT LTD,
 CUSTOMER LIAISON MANAGER,
 CH 6371 STANS, Tel: +41 41 619 65 09 (Government)
 SWITZERLAND Fax: +41 41 610 33 51

NOTE: Operators are requested to advise Pilatus Aircraft Ltd. of the Manufacturer's Serial Number (MSN), the flying hours and landings of aircraft which are allocated for this Service Bulletin using the Service Bulletin Evaluation Form.

B. Material Necessary for Each Aircraft

(1) Material to be Procured

If it is necessary to replace the EDP, send an order for a new EDP:

New Part No.	Description	Old Part No.	Qty	Disp. Code	Fig	Item
968.84.51.108	Fuel Pump	968.84.51.106	1	R	1	-

Disposition Codes: D - Discard / R - Return to Pilatus

(2) Additional Material to be Procured

These items are necessary only if you remove the EDP:

New Part No.	Description	Old Part No.	Qty	Disp. Code	Fig	Item
946.91.27.212	Packing, Preformed	946.91.27.212	2	D	-	-
968.20.11.687	Gasket	968.20.11.687	1	D	-	-

Disposition Codes: D - Discard / R - Return to Pilatus

(3) Operator Supplied Materials

Part No.	Description	Qty	Remarks
919.01.11.104	Lockwire 0.032 in. (0,8 mm) dia.	A/R	Relief-Valve-Cover Screws (Material Item P02-001)
919.01.11.103	Lockwire 0.025 in. (0,6 mm) dia.	A/R	EDP Housing Bolts (Material Item P02-007)

PILATUS
PC9
SERVICE BULLETIN

3. Accomplishment Instructions - Aircraft

A. Preparation

- (1) Open engine cowling ENG 3L and ENG 3R (Ref. AMM, 12-00-00, Page Block 1).

B. Inspection and Torque Check of the EDP Relief Valve (Ref. Fig. 1)

- (1) Visually inspect the joints between the EDP housing, relief valve housing and the relief valve cover for:

- Fuel leakage
- Gasket material pushed out

- (2) If the EDP shows signs of fuel leakage or the gasket between the EDP housing and the relief valve housing has been pushed out, replace the EDP (Ref. AMM, 28-20-10, Page Block 401).

- (3) Use a torque screwdriver to do a check of the torque value of the relief-valve-cover screws. Do the check clockwise only. The minimum torque must be 23 lbf in. (2,6 Nm).

NOTE: It is not necessary to remove the lockwire from the screws to do the check of the torque.

- (4) If the torque found at Step (3) is more than 23 lbf in. (2,6 Nm), it is not necessary to loosen the screws and torque them again.

- (5) If the relief-valve-cover screws are loose, or the torque found at Step (3) is less than 23 lbf in. (2,6 Nm), do as follows:

- (a) Cut, remove and discard the lockwire that safeties the relief-valve-cover screws.

- (b) Torque the screws gradually to between 23 and 25 lbf in. (2,6 and 2,83 Nm). Do this in the sequence shown in Figure 1, Detail B.

- (c) Safety the screws with lockwire (Material Item P02-001).

- (6) If you cannot get access to do the torque check with the EDP installed:

- Remove the EDP (Ref. AMM, 28-20-10, Page Block 401)
- Do Steps (1) thru (5)
- Install the EDP if serviceable (Ref. AMM, 28-20-10, Page Block 401).

C. Close up

- (1) Close engine cowling ENG 3L and ENG 3R (Ref. AMM, 06-20-00 or AMM, 12-00-00, Page Block 1).

- (2) Remove all tools and materials. Make sure the work areas are clean.

D. Documentation

- (1) Make an entry in the Aircraft Logbook that this Service Bulletin has been incorporated.

PILATUS
PC9
SERVICE BULLETIN

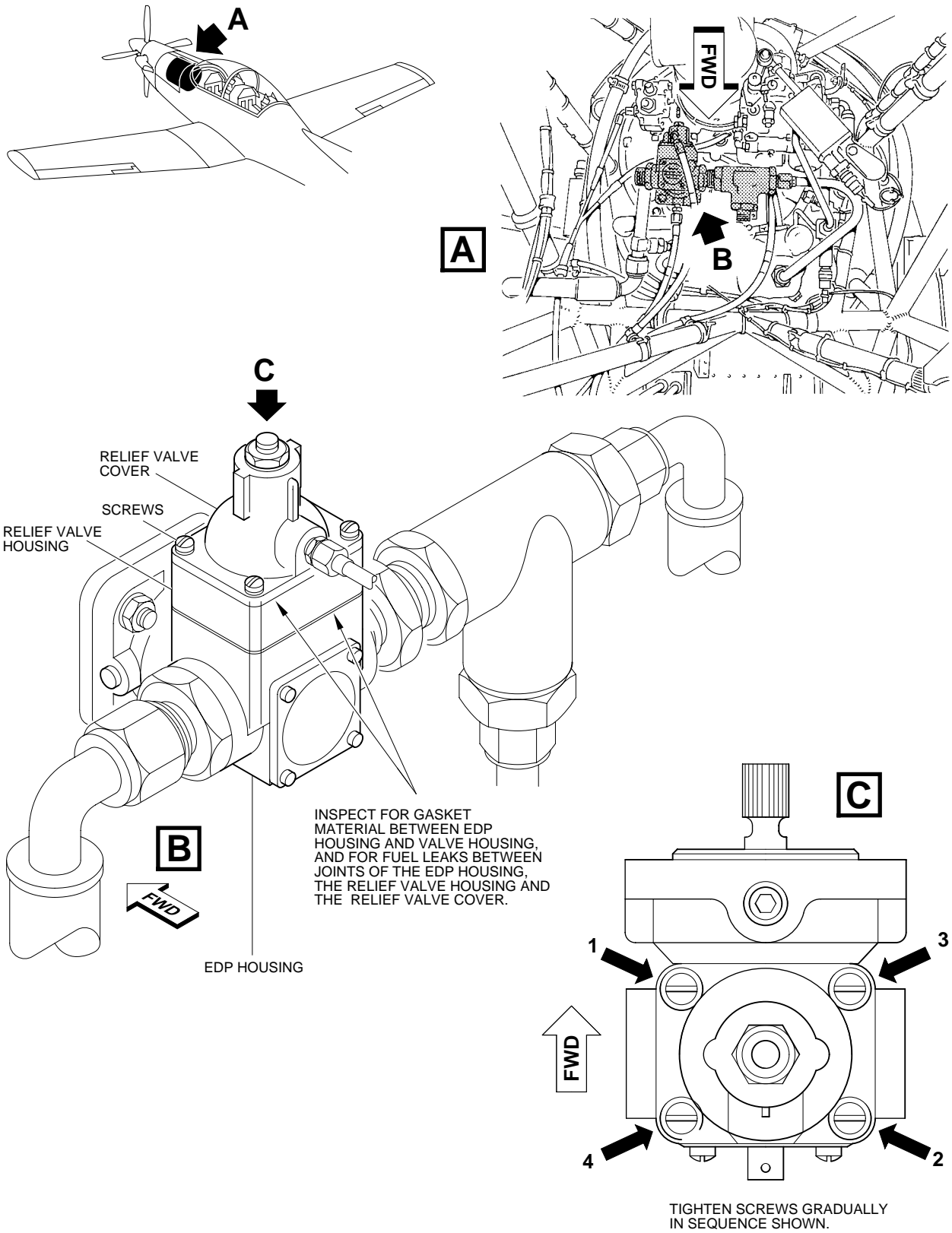

SB1100

Torque Check and Fuel Leak Inspection of the EDP
Figure 1