

Service Bulletin No: 53-010

Ref No: 70

Modification No: EC-09-0594

ATA Chapter: 53

**FUSELAGE - GENERAL
INSPECTION FOR GALVANIC CORROSION ON THE UPPER LEFT LONGERON AND REPLACEMENT
OF THE CHAFING PLATES****1. Planning Information****A. Effectivity**

PC-9(M) aircraft MSN 605 and MSN 617 thru MSN 670.

B. Concurrent Requirements

None.

C. Reason**(1) Problem**

Corrosion has been reported on the upper left longeron underneath the chafing plates for the canopy door latches.

(2) Cause

The cause of the corrosion can be due to a number of reasons, for example:

- The use of liquid shim
- Excessive latch chafing that damages and causes removal of the sealant and nucleation of further galvanic corrosion
- Poor application of sealant or finishes such as Alodine to the blended aluminium
- The use of chemical paint stripper.

(3) Solution

Do an inspection of the longeron in the specified areas and, if necessary, remove the corrosion. Apply to Pilatus for a repair scheme if the removal of corrosion decreases the metal thickness to less than the specified limits. Install new, more robust, chafing plates.

D. Description

This Service Bulletin gives the instructions and data necessary to:

- (1) Remove the chafing plates.
- (2) Do the inspection for corrosion on the longeron.
- (3) Install the new chafing plates.

E. Compliance

Mandatory.

Required within the next 120 days after the effective date of this Service Bulletin, unless already accomplished.

F. Approval

The technical content of this Service Bulletin is approved under FOCA approved procedures.

Pilatus advises Operators/Owners to check with their local Airworthiness Authorities for any changes, local regulations or sanctions that may affect the embodiment of this Service Bulletin.

G. Manpower

	Total (Corrosion not found)	Total (Corrosion found)
Preparation	0.75	0.75
Inspection/Corrosion removal	4.00	6.00
Surface finish removal/application	2.00	2.00
Installation	4.00	4.00
Close up	1.00	1.00
TOTAL MAN-HOURS	11.75	13.75

NOTE: Man-hours figures do not include the time required to cure sealants, paints and adhesives.

H. Weight and Balance**(1) Weight Change**

+175 gm (+0.386 lbs).

(2) Moment Change

Negligible.

I. Electrical Load Data

Not affected.

J. Software

Not changed.

K. References

Aircraft Maintenance Manual (AMM), 25-10-00, 25-30-02, 30-31-00, 52-10-00.

Structural Repair Manual (SRM), 51-10-01, 51-10-02.

L. Publications Affected

Illustrated Parts Catalogue (IPC), 52-10-01.

M. Interchangeability of Parts

Not applicable.

2. Material Information
A. Material - Price and Availability

Operators who require more information should contact:

PILATUS AIRCRAFT LTD,
 CUSTOMER LIAISON MANAGER,
 CH 6371 STANS, Tel: +41 41 619 62 26 (Government)
 SWITZERLAND Fax: +41 41 619 61 70

Modification Kit Number	Price	Availability
500.50.09.214	Contact address above	Contact address above

B. Material Necessary for Each Aircraft
(1) Material to be Procured

(a) Modification Kit No. 500.50.09.214 has these parts:

NEW PART NO.	DESCRIPTION	OLD PART NO.	QTY	DISP. CODE	FIG. NO.	ITEM NO.
553.20.09.326	CHAFING PLATE	553.20.09.206	3	D	1	1
553.20.09.327	CHAFING PLATE	553.20.09.207	1	D	1	8
935.63.11.065	SCREW	935.63.11.065	24	D	1	2
938.07.68.303	NUT	938.07.68.303	24	D	1	7
938.77.11.111	WASHER	938.77.11.111	24	D	1	6

Disposition Codes: D - Discard / N - New / R- Return to Pilatus

(2) Operator Supplied Materials (Ref. AMM, 20-31-00)

MATERIAL NO.	DESCRIPTION	QTY	REMARKS
P01-008	WHITE SPIRIT	A/R	Or equivalent
P02-009	ABRASIVE CLOTH, GRADE 120	A/R	Or equivalent
P02-011	ABRASIVE CLOTH, GRADE 240	A/R	Or equivalent
P02-014	ABRASIVE CLOTH, GRADE 400	A/R	Or equivalent
P02-016	SCOTCH BRITE	A/R	Or equivalent
P02-031	ABSORBENT PAPER	A/R	Or equivalent
P07-006	COCKPIT PAINT	A/R	Or equivalent
P07-007	EPOXY PRIMER	A/R	Or equivalent
P07-021	ALODINE 1132	A/R	Or equivalent
P08-018	SEALANT PR 1422B-2	A/R	Or equivalent

MATERIAL NO.	DESCRIPTION	QTY	REMARKS
P08-020	SEALANT PR 1422A-2	A/R	Or equivalent
P10-005	CPC-LIGHT	A/R	Or equivalent

C. Material Necessary for Each Spare

Not applicable.

D. Re-identified Parts

Not applicable.

E. Tooling - Cost and Availability

Not applicable.

3. Accomplishment Instructions

WARNING: MAKE SURE THAT THE TWO EJECTION SEATS HAVE THE SAFETY PINS INSTALLED IN THE SAFE FOR SERVICING LOCATIONS BEFORE YOU GO INTO THE COCKPIT. (REF. AMM, 25-10-00, PAGE BLOCK 201)

WARNING: BE CAREFUL WHEN YOU USE THE CONSUMABLE MATERIALS. OBEY THE MANUFACTURERS HEALTH AND SAFETY INSTRUCTIONS.

A. Preparation

- (1) Make sure the front and rear ejection seats are safe for servicing (Ref. AMM, 25-10-00, Page Block 201).
- (2) Remove the side panels from the left sides of the front and rear cockpits to get access to the work area (Ref. AMM, 25-30-02, Page Block 401).

B. Inspection (Ref. Fig. 1)**(1) Removal of the Chafing Plates**

- (a) Put some of the absorbent paper (Material No. P02-031) below where the chafing plate (8) and the chafing plates (1) are installed in the front and rear cockpits.

NOTE: This is to catch the unwanted material.

- (b) Remove and discard the nuts (7), the washers (6) and the screws (2).

NOTE: Make a note of the locations of the locking plate assemblies (5) and shim packs (4) when you remove them.

- (c) Remove the locking plate assemblies (5) and the shim packs (4).

CAUTION: BE CAREFUL WHEN YOU REMOVE THE CHAFING PLATE (8) AND THE CHAFING PLATES (1). DO NOT TO DAMAGE THE LONGERON (3).

- (d) Remove and discard the chafing plate (8) and the chafing plates (1).

(2) Do the Inspection for Corrosion on the Longeron

- (a) If installed, remove all the sealant from the longeron (3) as follows:

- 1 Remove as much of the sealant as possible with a non-metallic scraper.
- 2 Remove the remainder of the sealant with the absorbent paper (Material No. P02-031) made moist with the solvent (Material No. P01-008).

- (b) If installed, remove all the liquid shim material from the longeron (3) as follows:

- 1 Remove as much of the liquid shim as possible with a non-metallic scraper.
- 2 Remove the remainder of the liquid shim with the abrasive cloth (Material No. P02-009, P02-011 and P02-014) and the Scotch Brite (Material No. P02-016).

- 3 Clean the area with the absorbent paper (Material No. P02-031) made moist with the solvent (Material No. P01-008).

CAUTION: IF YOU MUST REMOVE THE SURFACE FINISH, DO NOT USE CHEMICAL PAINT STRIPPING METHODS TO REMOVE THE LAYERS OF PAINT FROM THE SURFACES OF THE LONGERON (3).

- (c) Use a X 10 magnifier and look for signs of corrosion in the areas of the chafing plates (1 and 8) on the upper and lower surfaces of the longeron (3) (Ref. SRM, 51-10-01).
- (d) If you find corrosion in Para. 3.B.(2)(c), obey the evaluation and assessment instructions (Ref. SRM, 51-10-02).
- (e) Remove the corrosion (Ref. SRM, 51-10-02) from the longeron (3).
- (f) After you have removed the corrosion in Para. 3.B.(2)(e), measure and record the thickness of the metal in the bare metal areas of the longeron (3). Make an entry in the Aircraft Logbook to record these values.

NOTE 1: You can use the feedback form (Ref. Fig. 2) to record the values.

NOTE 2: If you remove corrosion or you can see bare metal areas of the longeron (3), apply Alodine (Material No. P07-021) (Ref. Para. 3.B.(3)(c)) as soon as possible. If you do not apply the Alodine (Material No. P07-021) as soon as possible, the longeron (3) can become corroded again.

- (g) If the thickness of the remaining metal is less than:
- 1,8 mm (0.071 in.) at the FWD chafing plate (1) in the front cockpit
 - 2,3 mm (0.091 in.) at the AFT chafing plate (1) in the front cockpit
 - 2,1 mm (0.083 in.) at the FWD chafing plate (8) in the rear cockpit
 - 1,8 mm (0.071 in.) at the AFT chafing plate (1) in the rear cockpit,

use the feedback form (Ref. Fig. 2) to record the values and apply to Pilatus for a repair scheme. The address is:

Pilatus Aircraft LTD,
Customer Technical Support (MCC),
P.O. Box 992,
6371 Stans, Switzerland
Fax: ++41 (0)41 619 67 73
Email: Techsupport@pilatus-aircraft.com

- (h) If you do not find corrosion in Para. 3.B.(2)(c), measure and record the thickness of the metal in the bare metal areas of the longeron (3). Metal thickness which is less than 2.5 mm (0.098 in.) shows that a blend repair has been done in the area. Make an entry in the Aircraft Logbook to record the thickness if you find that a blend repair has been done.

NOTE: The correct thickness of the metal is 2.7 ± 0.2 mm (0.106 ± 0.008 in.). You can use the feedback form (Ref. Fig. 2) to record the values.

- (i) If the recorded metal thickness in Para. 3.B.(2)(h) is less than:
- 1,8 mm (0.071 in.) at the FWD chafing plate (1) in the front cockpit
 - 2,3 mm (0.091 in.) at the AFT chafing plate (1) in the front cockpit
 - 2,1 mm (0.083 in.) at the FWD chafing plate (8) in the rear cockpit
 - 1,8 mm (0.071 in.) at the AFT chafing plate (1) in the rear cockpit,

use the feedback form (Ref. Fig. 2) to record the values and apply to Pilatus for a repair scheme. The address is:

Pilatus Aircraft LTD,
Customer Technical Support (MCC),
P.O. Box 992,
6371 Stans, Switzerland
Fax: ++41 (0)41 619 67 73
Email: Techsupport@pilatus-aircraft.com

(3) Installation of the New Chafing Plates

- (a) If you removed corrosion from the longeron (3), make sure the areas of bare metal are a regular shape and all the paint, primer and Alodine are removed from the area.

NOTE: If you removed corrosion and did not apply the Alodine (Material No. P07-021) immediately, make sure that the longeron (3) has not become corroded again.

- (b) Remove the absorbent paper (Material No. P02-031) and all the unwanted material from the front and rear cockpits.
- (c) Read and obey the manufacturers instructions and apply a layer of the Alodine 1132 (Material No. P07-021) to the bare areas of the longeron (3). Let the Alodine 1132 (Material No. P07-021) become dry.
- (d) Read and obey the manufacturers instructions and mix sufficient primer (Material No. P07-007) for the areas to be treated.
- (e) Apply layers of the primer (Material No. P07-007) to the areas of the longeron (3) which have been treated with Alodine 1132 (Material No. P07-021). Let the primer (Material No. P07-007) become dry.
- (f) Read and obey the manufacturers instructions and mix sufficient paint (Material No. P07-006) for the areas to be treated.
- (g) Apply layers of the paint (Material No. P07-006) to the areas of the longeron (3) which have been treated with primer (Material No. P07-007). Let the paint (Material No. P07-006) become dry.
- (h) Read and obey the manufacturers instructions and mix sufficient sealant (Material No. P08-020) for the mating areas to be covered.
- (i) Apply a layer of the sealant (Material No. P08-020) to the mating areas of the chafing plates (1) and the chafing plate (8).

- (j) If applicable, make sure that you fully fill the blend repair areas of the longeron (3) with the sealant (Material No. P08-020). Do not leave spaces where moisture can collect.
 - (k) Put the new chafing plates (1) (P/N 553.20.09.326) and (8) (P/N 553.20.09.327) in position on the longeron (3).
 - (l) Put the locking plate assemblies (5) and shim packs (4) in their recorded locations on the longeron (3) (Ref. Para 3.B.(1)).
 - (m) Install the new screws (2) (P/N 935.63.11.065), the new washers (6) (P/N 938.77.11.111) and the new nuts (7) (P/N 938.07.68.303).
 - (n) Remove the unwanted sealant (Material No. P08-020).
 - (o) Read and obey the manufacturers instructions and mix sufficient sealant (Material No. P08-018) to make the beads around the applicable areas.
 - (p) Read and obey the manufacturers instructions and apply a bead of the sealant (Material No. P08-018) to:
 - The chafing plates (1)
 - The chafing plate (8)
- As shown in Detail C and Section D-D and E-E.
- (q) Apply a layer of the CPC-Light (Material No. P10-005) to the lower surface of the longeron (3) in the areas of the chafing plates (1) and the chafing plate (8).

C. Close up

- (1) Do this test to make sure the canopy closes correctly (Ref. Fig. 1):
 - (a) Make sure that all four hooks engage on the lugs in the fuselage.
 - (b) Make sure when the internal handle is released, the hooks stay engaged.
 - (c) If a hook does not stay engaged:
 - 1 Remove the screws (2), the washers (6) and the nuts (7), then remove the locking plate assembly (5) and the shim (4).
 - 2 Adjust the number of shims (4).
 - 3 Put the locking plate assembly (5) and the shims (4) in the correct position and install the screws (2), the washers (6) and the nuts (7).
 - (d) Do Para. 3.C.(1) (a) thru (c) again until all the hooks stay engaged on the lugs in the fuselage.
- (2) Check the operation of the canopy lock microswitch (Ref. 52-10-00, Page Block 501).
- (3) Remove all tools and materials and make sure the work area is clean.

- (4) Install the side panels on the left sides of the front and rear cockpits (Ref. AMM, 25-30-02, Page Block 401).

D. Documentation

- (1) Make an entry in the Aircraft Logbook that this Service Bulletin has been incorporated.
- (2) Use the Service Bulletin Evaluation Sheet and report your results and the serial number(s) of the aircraft to Pilatus.

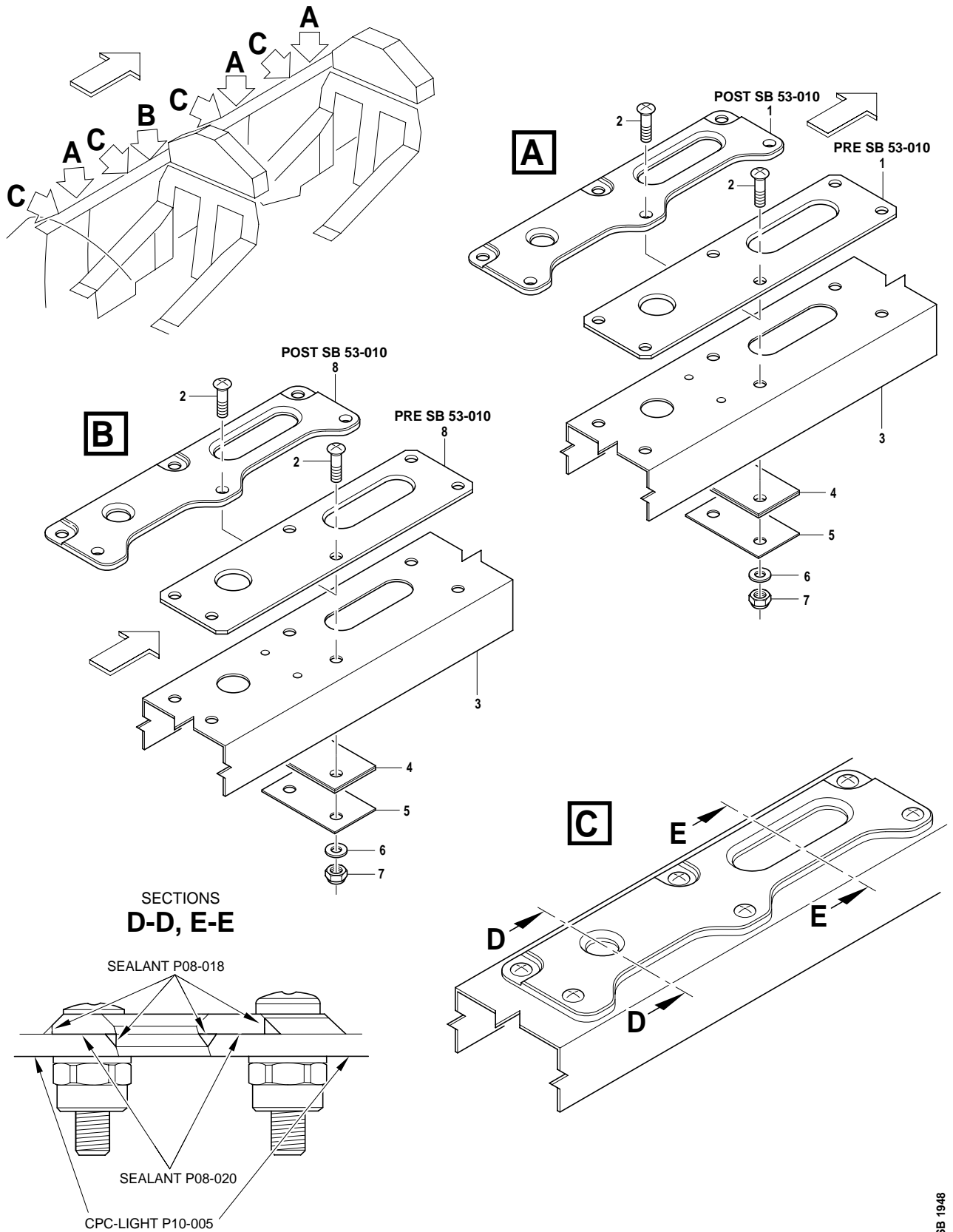

Canopy-lock Chafing Plates - Removal and Installation
Figure 1

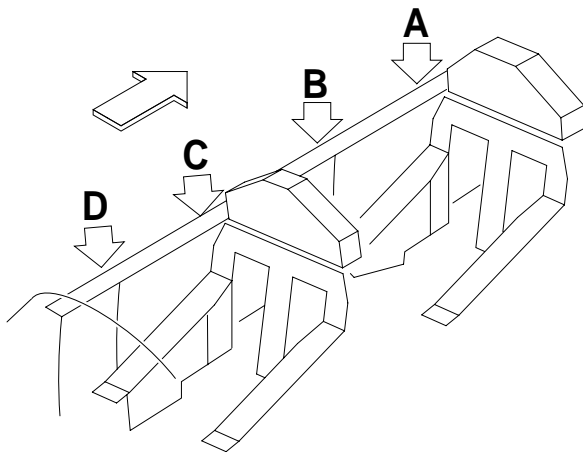

THE SCALE FOR VIEWS A THRU D
OF FIGURE 2 IS 1:1
EACH BLOCK OF THE GRID
IS 10 mm X 10 mm

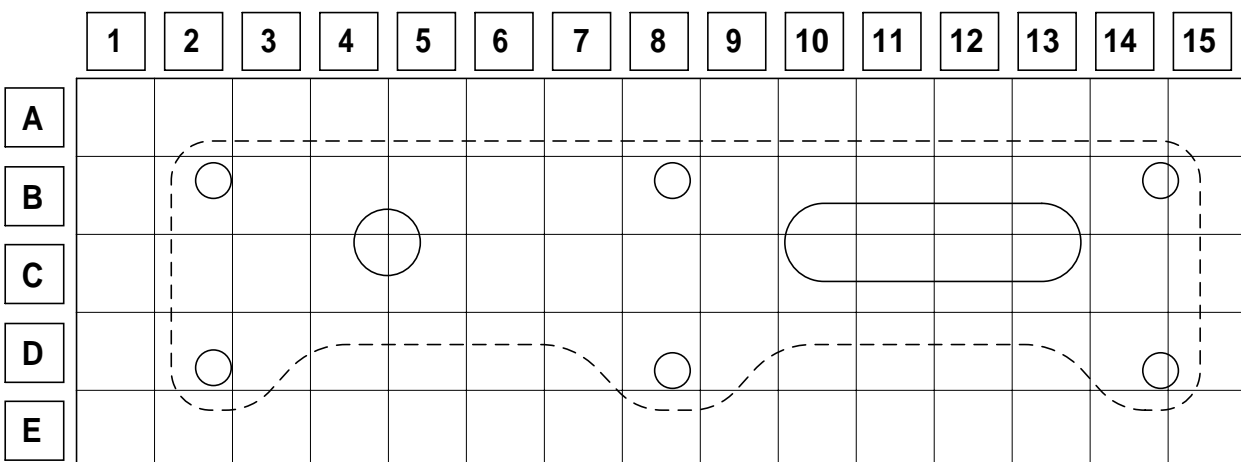
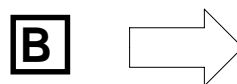
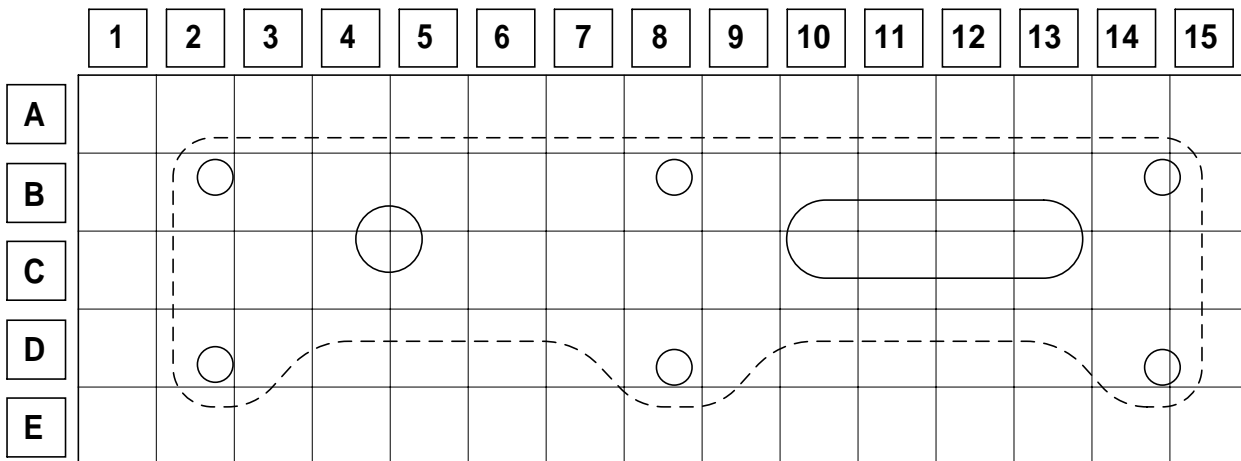
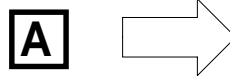

SB 1960

Feedback Form (Front Cockpit)
Figure 2, Sheet 1 of 2

C

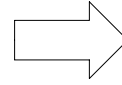

	1	2	3	4	5	6	7	8	9	10	11	12	13	14	15
A															
B		○		○				○		○				○	
C				○						○					
D		○							○						○
E															

D

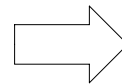

	1	2	3	4	5	6	7	8	9	10	11	12	13	14	15
A															
B		○		○				○		○				○	
C				○						○					
D		○							○						○
E															

MSN No: _____

TAIL No: _____

DATE: _____

FLYING HOURS _____

LANDINGS _____

Feedback Form (Rear Cockpit)
Figure 2, Sheet 2 of 2

INTENTIONALLY BLANK

SERVICE BULLETIN EVALUATION SHEET FOR SB No. 53-010			
Title	Fuselage - General Inspection for Galvanic Corrosion on the Upper Left Longeron and Replacement of the Chafing Plates		
Customer			
Service Center			
EMBODIMENT REPORTING			
This SB has been embodied:		<input type="checkbox"/>	On the entire fleet
		<input type="checkbox"/>	Only partially
Provide embodiment details per aircraft (use additional copies of this table, if necessary)			
MSN	Flying Hours	MSN	Flying Hours
Additional embodiment comments/findings			
EDITORIAL COMMENTS (procedure, kit quality, suggested improvements, etc.)			
Name	Signature	Date	
Please complete and forward this form to: Pilatus Aircraft LTD, Customer Technical Support (MCC), P.O. BOX 992, 6371 Stans, Switzerland Fax: +41 (0)41 619 6773 Email: Techsupport@pilatus-aircraft.com			

SERVICE BULLETIN EVALUATION SHEET

INTENTIONALLY BLANK