

# SERVICE BULLETIN

SERVICE BULLETIN NO: 30-001

REF NO: 61

MODIFICATION NO: INSPECTION

ATA CHAPTER: 30

## ICE AND RAIN PROTECTION - PITOT-STATIC AND AOA ANTI-ICE SYSTEM STATIC-PORT HEATER WIRES - INSPECTION

### 1. Planning Information

#### A. Effectivity

All PC-9(M) aircraft, up to and including MSN 670.

#### B. Concurrent Requirements

None

#### C. Reason

##### (1) Problem

An operator has reported a failure of the static-port heating.

##### (2) Cause

Chafing of electrical wires against a support strut for the condenser fan.

##### (3) Solution

Do an inspection of the wires to make sure they are not damaged and do not chafe against the support strut.

#### D. Description

This Service Bulletin gives the data and instructions necessary to:

- Do an inspection of the static-port heater wires adjacent to the condenser-fan support-strut.
- If necessary, apply protective tape to prevent damage.
- If necessary, replace damaged wires.

#### E. Compliance

Mandatory.

Within 30 days of the issue date of this Service Bulletin.

**≡PILATUS≡**  
**MODULAR TRAINER**  
**SERVICE BULLETIN**

**F. Approval**

The technical content of this document is approved under FOCA accepted procedures.

PILATUS advises Operators/Owners to check with their local Airworthiness Authorities for any changes, local regulations or sanctions that may affect the embodiment of this Service Bulletin.

**G. Manpower**

	Total
Preparation	0.10
Inspection	0.25
Test	0.25
Close up	0.10
<b>TOTAL MAN-HOURS</b>	<b>0.70</b>

**H. Weight and Balance**

**(1) Weight Change**

Not affected.

**(2) Moment Change**

Not affected.

**I. Electrical Load Data**

Not changed.

**J. Software**

Not changed.

**K. References**

Aircraft Maintenance Manual (AMM) 06-20-00, 20-31-00, 24-00-00, 25-10-00, 30-30-00.

**L. Publications Affected**

Not applicable.

**M. Interchangeability of Parts**

Not applicable.

**≡PILATUS≡**  
**MODULAR TRAINER**  
**SERVICE BULLETIN**

**2. Material - Price and Availability**

A Modification Kit is not necessary for this Service Bulletin.

**A. Material Necessary for Each Aircraft**

**(1) Material to be Purchased**

Not applicable.

**(2) Operator Supplied Materials (Ref. AMM 20-31-00).**

Material No.	Description	Qty	Remarks
P09-008	Cable Ties	A/R	If required
P09-020	Glass-fiber Tape	A/R	If required

**B. Material Necessary for Each Spare**

Not applicable.

**C. Re-identified Parts**

Not applicable.

**D. Tooling - Cost and Availability**

Not applicable.

**≡PILATUS≡**  
**MODULAR TRAINER**  
**SERVICE BULLETIN**

**3. Accomplishment Instructions**

**WARNING:** MAKE SURE THAT BOTH EJECTION SEATS HAVE THE SAFETY PINS INSTALLED IN THE SAFE FOR SERVICING LOCATIONS BEFORE YOU GO IN THE COCKPIT (REF. AMM 25-10-00, PAGE BLOCK 201).

**A. Preparation**

- (1) In the front cockpit, open and install safety clips to the circuit breakers:

PROBES 1 (GENERATOR BUS CB panel)  
PROBES 2 (GENERATOR BUS CB panel)

- (2) Remove the access panel F12 (Ref. AMM 06-20-00, Page Block 1).

**B. Inspection (Ref. Fig. 1)**

- (1) Examine the wires connected to TB701-01 to see if they can touch the support-strut for the condenser blower motor:

(a) If the wires do not touch the strut, and you cannot move them to make them touch, no further action is necessary. Continue the procedure at Para. C. Test.

(b) If the wires touch the strut, or if you can move them to make them touch:

(i) Use a bright light source and X10 magnifier to examine the wires for chafing or burning.

(ii) If you find signs of melting, burning or the insulation is worn so that you can see the metal wire inside, you must replace the wire(s). Obey the safety precautions given in AMM 24-00-00, Page Block 201.

(iii) Apply glass-fiber tape (Material No. P09-020) around the support-strut where the wires can touch.

(iv) If possible, attach the wires to the support-strut with cable ties (Material No. P09-008) to prevent movement. Do not do this if it puts strain on the wires.

**C. Test**

- (1) In the front cockpit, remove the safety clips and close the circuit breakers:

PROBES 1 (GENERATOR BUS CB panel)  
PROBES 2 (GENERATOR BUS CB panel)

- (2) Do the Adjustment/Test of the Pitot-Static and AOA Anti-Ice System (Ref. AMM 30-30-00, Page Block 501).

**D. Close Up**

- (1) Remove all tools and materials. Make sure the work areas are clean.

- (2) Install the access panel F12 (Ref. AMM 06-20-00, Page Block 1).

**PILATUS**  
**MODULAR TRAINER**  
**SERVICE BULLETIN**

**E. Reporting Action**

Operators are requested to report the result of the inspection to Pilatus Aircraft Ltd. Please include:

- If it was found possible for the wires to touch the support-strut (or not)
- If any damage was found (or not)
- If it was found necessary to replace wires.

**F. Documentation**

Make an entry in the Aircraft Logbook that this Service Bulletin has been incorporated.

**4. Accomplishment Instructions - Spares**

Not applicable.

**PILATUS**  
**MODULAR TRAINER**  
**SERVICE BULLETIN**

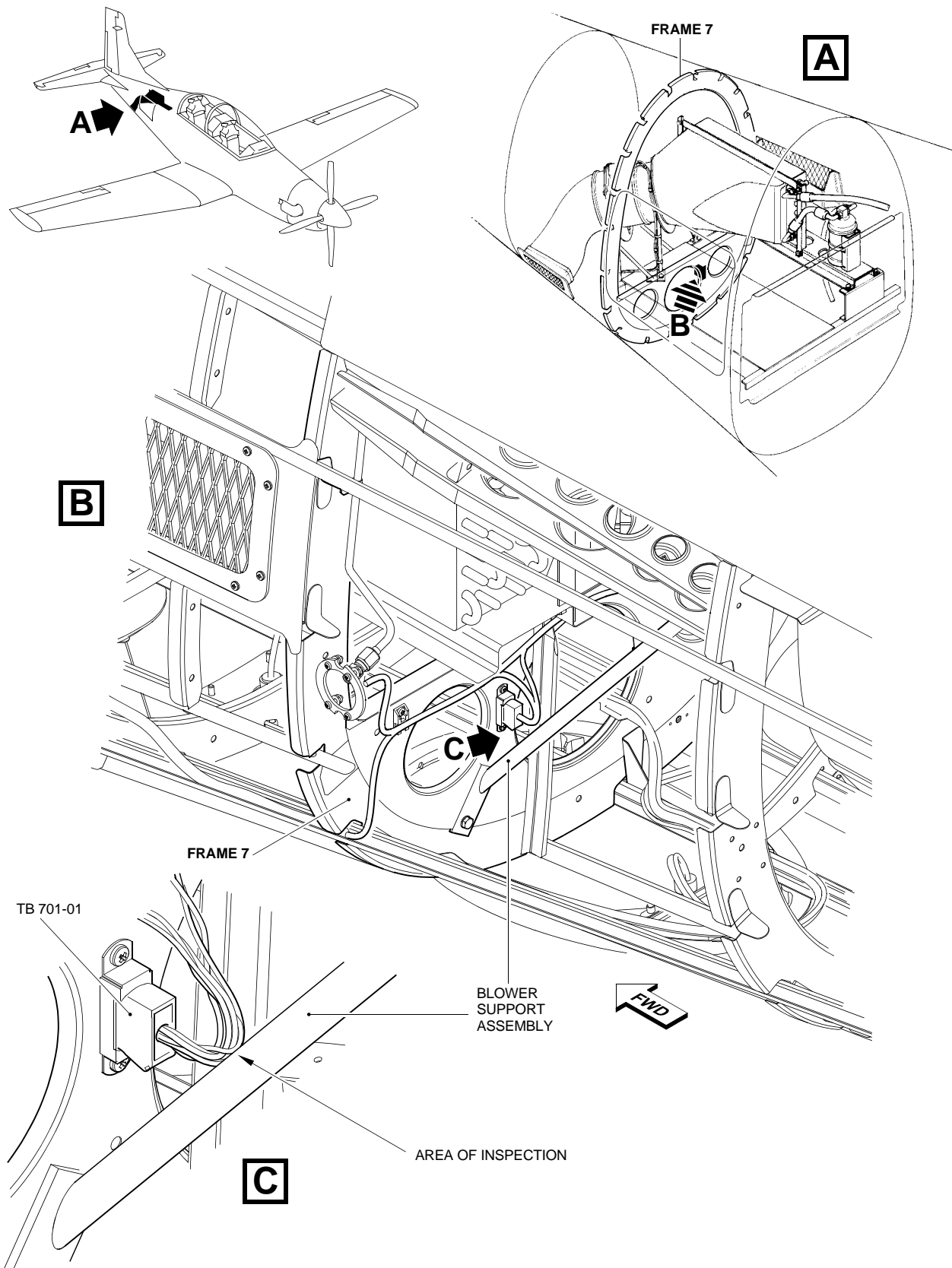

Inspection  
Figure 1