

SERVICE BULLETIN

SERVICE BULLETIN NO: 32-025

REF NO: 126

MODIFICATION NO: EC-08-0400

ATA CHAPTER: 32

LANDING GEAR - MAIN GEAR REPLACEMENT OF THE MAIN-GEAR SUPPORT STRUT

1. Planning Information

A. Effectivity

All PC-7 aircraft.

B. Concurrent Requirements

None.

C. Reason

(1) Problem

Cracks have occurred in the main-gear support struts on some aircraft. All the main-gear support struts that had cracks were made from material AA2024-T351. This material has a lower resistance to stress corrosion cracking.

(2) Cause

The cause of the cracks is stress corrosion.

(3) Solution

Replace the main-gear support strut with a new item made from the material with an increased resistance to stress corrosion cracking.

D. Description

This Service Bulletin gives the data and instructions necessary to replace the main-gear support strut.

Revision 1 incorporates these changes:

- Title changed
- Modification Kit changed to add Support Strut P/N 114.48.07.127 and to add a Note about not required rivets
- Microswitch striker deleted from Figs 1 and 2. Procedure amended to delete the installation of the striker and change the item numbering.
- Approval statement changed and minor editorial and formatting changes.

E. Compliance

Highly Recommended.

≡PILATUS≡
PC-7
SERVICE BULLETIN

F. Approval

The technical content of this Service Bulletin is approved under FOCA accepted procedures.

PILATUS advises Operators/Owners to check with their local Airworthiness Authorities for any changes, local regulations or sanctions that may affect the embodiment of this Service Bulletin.

G. Manpower

	Total
Preparation	1.0
Inspection	8.0
Close up	3.0
TOTAL MAN-HOURS	12.0

NOTE: Man-hours figures do not include the time required to cure sealants and adhesives.

H. Weight and Balance

(1) Weight Change

Not affected.

(2) Moment Change

Not affected.

I. Electrical Load Data

Not affected.

J. Software

Not affected.

K. References

Aircraft Maintenance Manual (AMM) 20-31-00, 32-10-02, 32-30-00.

Structural Repair Manual (SRM), 51-00-04.

L. Publications Affected

Illustrated Parts Catalogue (IPC) 32-10-02.

M. Interchangeability of Parts

Pre and Post SB 32-025 parts are not interchangeable.

PILATUS PC-7 SERVICE BULLETIN

2. Material Information

A. Material - Price and Availability

Operators should send orders for Service Bulletin modification kits, to:

PILATUS AIRCRAFT LTD,
CUSTOMER LIAISON MANAGER,
CH 6371 STANS, Tel: +41 41 619 62 26 (Government)
SWITZERLAND Fax: +41 41 619 61 70

NOTE: Operators are requested to advise Pilatus Aircraft Ltd, using the Service Bulletin Evaluation Sheet, of the Manufacturer's Serial Number (MSN) and the flying hours of aircraft which are allocated for this Service Bulletin.

Modification Kit Number	Price*	Availability
500.50.09.062	Contact address above	Contact address above

Tool Kit Number	Price*	Availability
513.32.09.118	Contact address above	Contact address above

B. Material Necessary for Each Aircraft

(1) Material to be Purchased

Part Numbers, given in this Service Bulletin, are correct at the time of approval. PILATUS AIRCRAFT LTD. reserves the right to change the part numbers as necessary.

Part numbers of items, delivered with the Modification and Tool Kits, are correct when the kit is dispatched which could lead to differences between those quoted in this Service Bulletin and the Modification and Tool Kits.

Operators must order the following kits from PILATUS if the main-gear support strut is replaced on their aircraft

Modification Kit No. 500.50.09.062 modifies one main gear folding strut assembly. It has these parts:

NEW PART NO.	DESCRIPTION	OLD PART NO.	QTY	DISP. CODE	FIG	ITEM
532.10.09.128	SUPPORT STRUT	532.10.09.039 or 114.48.07.127	1	N	1	4
532.10.09.133	LOCKWASHER	N/A	1	N	1	13
932.35.14.227	BOLT NAS6605-27	932.19.60.261	1	N	1	5
DISPOSITION CODES: N - NEW						

PILATUS
PC-7
SERVICE BULLETIN

NEW PART NO.	DESCRIPTION	OLD PART NO.	QTY	DISP. CODE	FIG	ITEM
938.75.11.311	WASHER	938.78.11.206	1	N	1	6
114.48.07.133	BUSH	114.48.07.133	1	N	1	7
938.07.68.305	NUT	938.07.68.305	1	N	1	11
939.17.81.255	RIVET, SOLID MS20470AD5-8	N/A	2	NOTE: These rivets are not required for PC-7 aircraft.		
DISPOSITION CODES: N - NEW						

Tool Kit No. 513.32.09.118 can be used on more than one aircraft. It has these parts:

NEW PART NO.	DESCRIPTION	QTY	FIG	ITEM
513.32.09.119	DRILLING JIG	1	2	-
513.32.09.120	HOLDER	1	2	-
513.32.09.122	STEP DRILL	1	2	-
513.32.09.123	CLAMPING BOLT	2	2	-
513.32.09.124	HOLE ALIGNMENT TOOL	1	2	-
901.80.02.030	HAND REAMER	1	2	-

(2) Operator Supplied Materials (Ref. AMM 20-31-00):

MATERIAL No.	DESCRIPTION	QTY	REMARKS
P04-012	CORROSION PREVENTATIVE	A/R	PIL P/N 910.31.20.040
P07-021	ALODINE 1132	A/R	PIL P/N 908.40.32.252
P08-057	SEALANT	A/R	PIL P/N 907.10.11.244
P10-013	CPC-highT/Exterior	A/R	PIL P/N 908.18.12.086

C. Material Necessary for Each Spare

Not applicable.

D. Re-identified Parts

Not applicable.

≡PILATUS≡
PC-7
SERVICE BULLETIN

3. Accomplishment Instructions

A. Main Gear Folding Strut Removal

- (1) Remove the main-gear folding-strut assembly (Ref. AMM 32-10-02, Page Block 401).

B. Remove the Main-Gear Support Strut (Ref. Fig. 1)

- (1) Remove and discard the lockwire from the bolt (5).
- (2) Remove and discard the bolt (5), the washer (6) and the bush (7) that attach the main-gear support strut (4) to the upper folding strut (8).
- (3) Loosen, but do not remove, the bolts (1) and (12).
- (4) Remove the nut (11), the washers (10) and the bolt (9).
- (5) Move the folding strut lever (2) away from the main-gear support strut (4).

CAUTION: DO NOT USE TOO MUCH HEAT TO REMOVE THE MAIN-GEAR SUPPORT STRUT (4). DO NOT EXCEED 120°C (224°F) FOR MORE THAN 15 MINUTES.

- (6) Remove the main-gear support strut (4). If the main-gear support strut (4) is difficult to remove, apply heat to the area.
- (7) Discard the main-gear support strut (4).

C. Install the New Main-Gear Support Strut (Ref. Fig. 1)

WARNING: BE CAREFUL WHEN YOU USE THE CONSUMABLE MATERIALS. OBEY THE MANUFACTURERS HEALTH AND SAFETY INSTRUCTIONS.

- (1) Apply a layer of corrosion preventative compound (Mat. No. P04-012) to the bush (7) (114.48.07.133) and put it in position in the upper folding strut (8).
- (2) Temporarily install, but do not fully tighten, the bolt (5) (P/N 932.35.14.227), the lock washer (13) (P/N 532.10.09.133) and the washer (6) (P/N 938.75.11.311) to attach the main-gear support strut (4) (P/N 532.10.09.128) to the upper folding strut (8).
- (3) Engage the folding strut lever (2) in the main-gear support strut (4).
- (4) Make the Holes in the Main-Gear Support Strut the Correct Size (Ref. Figs. 1 and 2)
 - (a) Put the drilling jig (P/N 513.32.09.119) into one of the holes in the folding strut lever (2). Make sure the step on the drilling jig (P/N 513.32.09.119) engages in the hole of the folding strut lever (2).
 - (b) Put the holder (P/N 513.32.09.120) in position on the drilling jig (P/N 513.32.09.119) and install the two clamping bolts (P/N 513.32.09.123). Do not tighten the two clamping bolts (P/N 513.32.09.123).
 - (c) Use the hole alignment tool (P/N 513.32.09.124) to align the holes in the folding strut lever (2) and the main-gear support strut (4) (P/N 532.10.09.128).

PILATUS
PC-7
SERVICE BULLETIN

- (d) When the holes in the folding strut lever (2) and the main-gear support strut (4) (P/N 532.10.09.128) align:
- Install the bolt (9), the washers (10) and the nut (11)
 - Tighten the bolts (1) and (12)
 - Tighten the two clamping bolts (P/N 513.32.09.123)
 - Tighten the bolt (5).
- (e) Use the step drill (P/N 513.32.09.122) to increase the diameter of the other hole in the main-gear support strut (4) (P/N 532.10.09.128) to 7.6 mm.
- (f) Remove the two clamping bolts (P/N 513.32.09.123) and the holder (P/N 513.32.09.120) and put the drilling jig (P/N 513.32.09.119) in the other hole in the folding strut lever (2). Make sure the step on the drilling jig (P/N 513.32.09.119) engages in the hole of the folding strut lever (2).
- (g) Put the holder (P/N 513.32.09.120) in position on the drilling jig (P/N 513.32.09.119) and install the two clamping bolts (P/N 513.32.09.123).
- (h) Use the step drill (P/N 513.32.09.122) to increase the diameter of the other hole in the main-gear support strut (P/N 532.10.09.128) to 7.6 mm.
- (i) Remove the two clamping bolts (P/N 513.32.09.123), the holder (P/N 513.32.09.120) and the drilling jig (P/N 513.32.09.119).
- (j) Remove the bolt (5), the lock washer (13) and the washer (6).
- (k) Loosen, but do not remove, the bolts (1) and (12).
- (l) Remove the nut (11), the washers (10) and the bolt (9). Discard the nut (11).
- (m) Move the folding strut lever (2) away from the main-gear support strut (4).
- (n) Remove the main-gear support strut (4) (P/N 532.10.09.128).
- (o) Use the reamer (P/N 901.80.02.030) and increase the diameter of the holes in the main-gear support strut (4) (P/N 532.10.09.128) to 7.938 + 0.015 - 0.0 mm (0.3125 + 0.0006 - 0.0 in.).
- NOTE:** Pilatus recommends you use a pillar drill or similar tool. Make sure the reamer in the pillar drill is perpendicular to the main-gear support strut (4) (P/N 532.10.09.128) and aligned to the center of the hole.
- (5) Deburr the holes in the main-gear support strut (4) (P/N 532.10.09.128).
- (6) Apply a layer of Alodine 1132 (Mat. No. P07-021) to the bare metal surfaces of the holes.
- (7) Apply a layer of corrosion preventative compound (Mat. No. P04-012) to the bolt (5) (P/N 932.35.14.227), the lock washer (13) (P/N 532.10.09.133) and the washer (6) (P/N 938.75.11.311).
- (8) Loosely install the bolt (5) (P/N 932.35.14.227), the lock washer (13) (P/N 532.10.09.133) and the washer (6) (P/N 938.75.11.311) to attach the main-gear support strut (4) (P/N 532.10.09.128) to the upper folding strut (8).
- (9) Temporarily install the bolt (3).

≡PILATUS≡
PC-7
SERVICE BULLETIN

- (10) Torque the bolt (5) (P/N 932.35.14.227) to between 7,0 and 9,5 Nm (60 and 85 lb. in.).
- (11) Safety the bolt (5) (P/N 932.35.14.227) with the lock washer (13) (P/N 532.10.09.133).
- (12) Apply a layer of corrosion preventative (Material No. P10-013) to the head of the bolt (5) (P/N 932.35.14.227), the lock washer (13) (P/N 532.10.09.133) and the washer (6) (P/N 938.75.11.311).
- (13) Install the bolt (9), the washers (10) and the new nut (11) (P/N 938.07.68.305).
- (14) Tighten the nuts on the bolts (1) and (12) and the new nut (11) (P/N 938.07.68.305) to between 3,4 and 4,5 Nm (30 and 40 lb. in.).
- (15) Remove the bolt (3).
- (16) Install the main-gear folding-strut assembly (Ref. AMM, 32-10-02, Page block 401).

D. Close up

- (1) Do the landing-gear Functional Test, Check 9 - MLG Down Microswitches S17 (LH) (Ref. AMM 32-30-00, Page Block 501).
- (2) Do the landing-gear Functional Test, Check 11 - MLG Down Microswitches S18 (RH) (Ref. AMM 32-30-00, Page Block 501).
- (3) Do a landing gear operational test (Ref. AMM 32-30-00, Page Block 501).
- (4) Make sure the work area is clean and clear of tools and other items.

E. Documentation

- (1) Make an entry in the Aircraft Logbook that this Service Bulletin has been incorporated.
- (2) Use the Service Bulletin Evaluation Sheet to report your results and the serial number of the modified aircraft to PILATUS.



PILATUS

PC-7

SERVICE BULLETIN

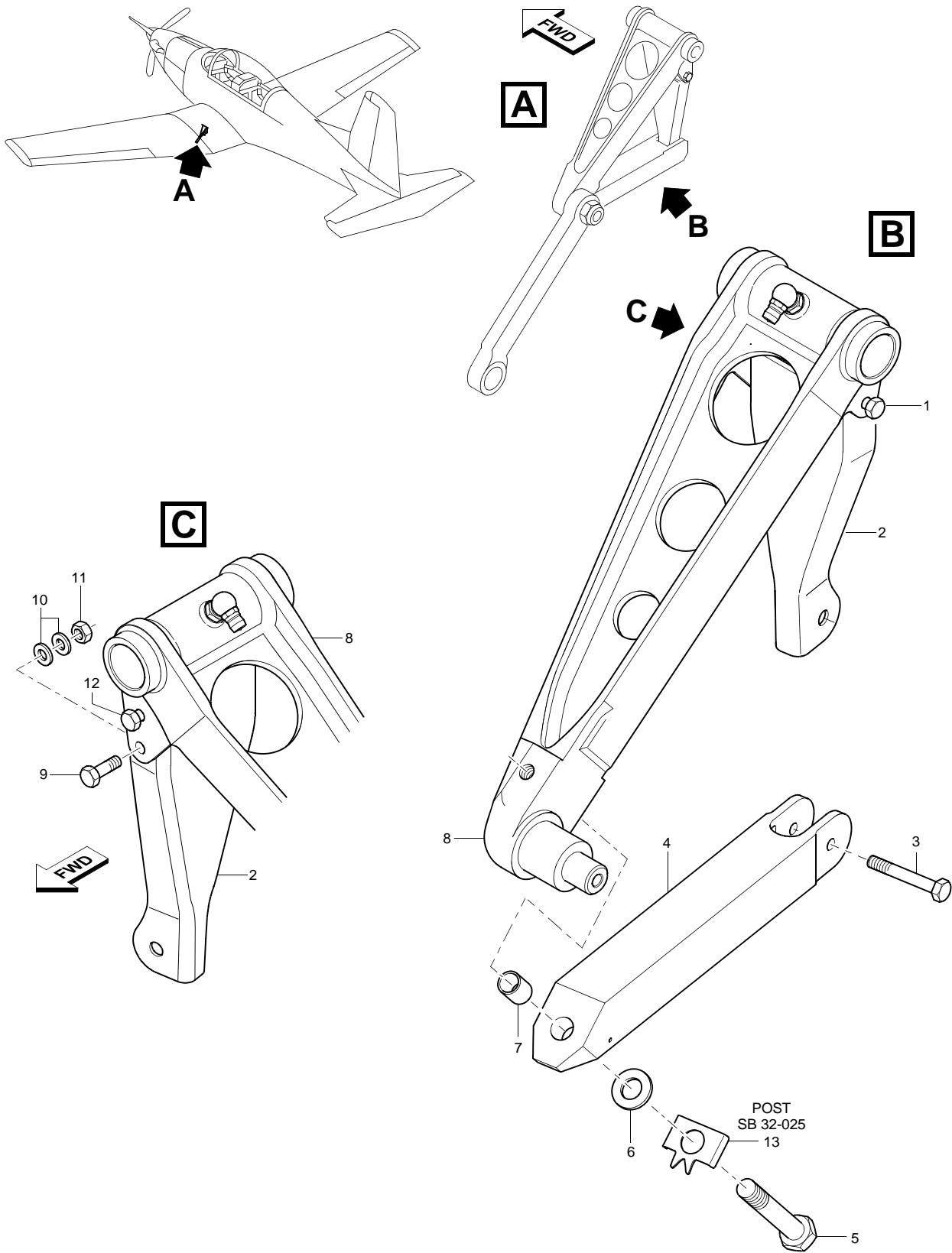

SB1791

Support Strut Removal/Installation
Figure 1

PILATUS
PC-7
SERVICE BULLETIN

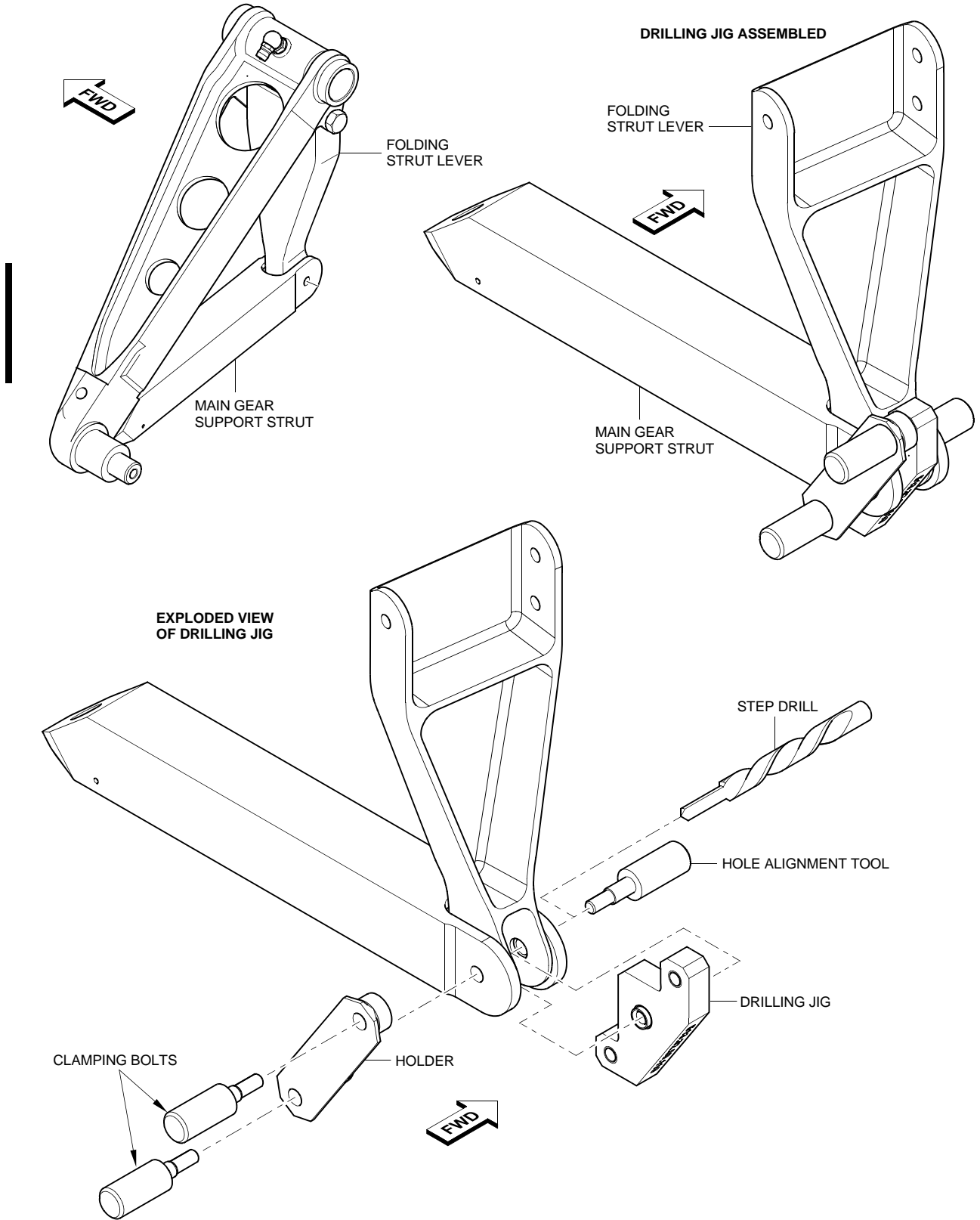

Make the Holes in the Main-Gear Support Strut the Correct Size
Figure 2

≡PILATUS≡
PC-7
SERVICE BULLETIN

INTENTIONALLY BLANK

