

Service Bulletin No: 52-005

Ref No: 126

Modification No: EC-14-0175

ATA Chapter: 52

**CANOPY - GENERAL
INSPECTION FOR CORRECT INSTALLATION OF THE HINGE ATTACHMENT RIVNUTS****1. Planning Information****A. Effectivity**

Canopy Assemblies with the following Serial Numbers originally delivered installed on Aircraft MSNs 675 thru 715:

Serial Number	Serial Number
6455	6571
6458	6573 thru 6583
6459	6586
6476	6594
6477	6596 thru 6598
6480 thru 6484	6600
6563 thru 6566	6603 thru 6610
6568	

Canopy Assemblies with the following Serial Numbers originally delivered as spares:

Serial Number
6460
6572
6620

B. Concurrent Requirements

None.

C. Reason**(1) Problem**

On some canopy assemblies, the rivnuts which attach the hinge to the canopy frame may not be correctly installed.

(2) Solution

Do a borescope inspection of the interior of the canopy frame. If the rivnuts are not correctly installed, use a hand tool to correctly install the rivnuts.

D. Description

This Service Bulletin gives the data and instructions necessary to do an inspection of the rivnuts and, if necessary, install them correctly.

E. Compliance

Mandatory.

Required within 1 year after the effective date of this Service Bulletin.

F. Approval

The technical content of this Service Bulletin is approved under the authority of Letter of DOA Acceptance ref. FOCA.21J.002.

Pilatus advises Operators/Owners to check with their designated Airworthiness Authorities for any changes, local regulations or sanctions that may affect the embodiment of this Service Bulletin.

G. Copyright Information

© Pilatus Aircraft Ltd. This document contains proprietary information that is protected by copyright. All rights are reserved. No part of this document may be copied, reproduced or translated to other languages without the prior written consent of Pilatus Aircraft Ltd.

H. Manpower

	Total (Aircraft)	Total (Spares)
Preparation	1.0	-
Inspection	0.5	0.5
Preparation for Installation (if required)	2.0	0.5
Installation (if required)	1.0	1.0
Close up	4.0	-
TOTAL MAN-HOURS	8.5	2.0

I. Weight and Balance

(1) Weight Change

None.

(2) Moment Change

None.

J. Electrical Load Data

Not changed.

K. Software

Not changed.

L. References

Aircraft Maintenance Manual (AMM): 25-10-00, 52-10-01.

M. Publications Affected

None.

N. Interchangeability of Parts

A Pre SB 52-005 Canopy Assembly must not be installed on a Post SB 52-005 aircraft.

NOTE: Interchangeability is not affected for canopy assemblies not included in the effectivity of this Service Bulletin.

2. Material Information

A. Material - Price and Availability

No Modification Kit is necessary to do this Service Bulletin.

Operators who require further information on the price and availability of the Rivnut Handtool should contact their Customer Liaison Manager at Pilatus Aircraft Ltd., 6371 Stans, Switzerland.

Operators are requested to advise Pilatus Aircraft Ltd, using the Service Bulletin Evaluation Sheet, of the Manufacturer's Serial Number (MSN) and the flying hours of aircraft which are allocated for this Service Bulletin.

B. Material Necessary for Each Aircraft

(1) Consumable Materials

Material No.	Description	Remarks
-	LIGHT MACHINE OIL	LOCAL SUPPLY

C. Material Necessary for Each Spare

(1) Consumable Materials

Material No.	Description	Remarks
-	LIGHT MACHINE OIL	LOCAL SUPPLY

D. Re-identified Parts

After accomplishment of this Service Bulletin the canopy assembly is to be marked 'Post SB 52-005'.

E. Tooling - Cost and Availability

NOTE: The Rivnut Handtool is only required if you find rivnuts that are not correctly installed. Only one Borescope and Rivnut Handtool is required for an aircraft fleet.

TOOL NO.	DESCRIPTION	QTY	REMARKS
-	FLEXIBLE BORESCOPE (MAX. 5 MM DIAMETER)	1	LOCAL SUPPLY
513.53.09.029	RIVNUT HANDTOOL, 8-32 THREAD	1	REF. PARA 2.A.

3. Accomplishment Instructions - Aircraft**A. Preparation**

WARNING: MAKE SURE THE TWO EJECTION SEATS HAVE THE SAFETY PINS INSTALLED IN THE SAFE FOR SERVICING LOCATIONS BEFORE YOU GO INTO THE COCKPIT (REF AMM 25-10-00, PAGE BLOCK 201).

- (1) Fully open the canopy.

B. Inspection of the Rivnuts (Ref. Fig. 1)

- (1) Put the flexible borescope through the tooling hole in the right side of the front frame of the canopy.
- (2) Push the flexible borescope into the right side frame until you can see the rivnuts.
- (3) Examine the first four hinge attachment-screw rivnuts (minimum).
- (4) If the rivnuts have a bulge they are correctly installed. Remove the borescope and do the re-identification procedure (Ref. Para. F.).
- (5) If the rivnuts are cylindrical with no bulge they are not correctly installed. Continue with the rivnut installation procedures.

C. Preparation for Installation of the Rivnuts

- (1) Remove the canopy (Ref. AMM 52-10-01, Page Block 401).
- (2) Examine all 33 hinge attachment-screw rivnuts for security of attachment. If you find a rivnut that is loose, or has a gap between the countersunk head and the countersink, it is not serviceable. Contact Pilatus Aircraft Ltd. for repair information.

D. Installation of the Rivnuts (Ref. Fig. 2)

CAUTION: DO THIS PROCEDURE FOR ALL 33 HINGE ATTACHMENT-SCREW RIVNUTS. KEEP THE THREADS ON THE PULL-UP STUD AND JACK SCREW WELL LUBRICATED WITH LIGHT MACHINE OIL DURING THE PROCEDURE.

- (1) If the rivnuts are serviceable, use the Rivnut Handtool (P/N 513.53.09.029) and pull the rivnuts as follows (Ref. Fig. 2):
 - (a) Install the hand tool in the rivnut (Ref. Fig. 2a):
 - 1 Engage the threads of the pull-up stud (on the hand tool) with the threads of the installed rivnut.
 - 2 Turn the complete tool clockwise to fully install the pull up stud in the rivnut.
 - 3 Turn the anvil until it is tight against the head of the rivnut.

- (b) Pull the rivnut (Ref. Fig. 2b):

CAUTION: MAKE SURE YOU HOLD THE HAND TOOL PERPENDICULAR TO THE SURFACE OF THE CANOPY FRAME. YOU MUST NOT INSTALL THE RIVNUT AT AN ANGLE.

- 1 Insert the hexagonal wrench in the jackscrew of the hand tool.

CAUTION: DO NOT PERMIT THE HEXAGONAL WRENCH TO TURN WHEN YOU PULL THE RIVNUT. DAMAGE TO THE HANDTOOL CAN RESULT.

- 2 Hold the hexagonal wrench stationary.

CAUTION: DO NOT TURN THE LARGE HEXAGONAL NUT MORE THAN 3/4 OF A TURN. DAMAGE TO THE HANDTOOL CAN RESULT.

- 3 Use a wrench to turn the large hexagonal nut counter-clockwise for 3/4 of a turn.

NOTE: 3/4 of a turn is the maximum required to completely deform the sleeve of a rivnut that is not correctly installed.

- (c) Loosen the hand tool (Ref. Fig. 2c):

- 1 Hold the hexagonal wrench stationary.

- 2 Break the large hexagonal nut loose with a clockwise turn.

- 3 Remove the two wrenches from the hand tool.

- (d) Remove the hand tool (Ref. Fig. 2d):

- 1 Turn the complete tool counter-clockwise to remove the pull-up stud from the rivnut.

- 2 Remove the hand tool.

E. Close-Up

- (1) Install the canopy (Ref. AMM 52-10-01, Page Block 401).
- (2) Remove all equipment, materials and tools from the work area. Make sure that the work area is clean.

F. Re-identification

- (1) Find the canopy identification placard. The placard is installed:

- on the rear frame of the canopy
- or
- on the side frame of the canopy, near the rear frame.

- (2) Use a suitable indelible marker pen to write 'Post SB 52-005' adjacent to the placard.

G. Reporting Action

Report the results of the inspection to Pilatus Aircraft Ltd. Include the aircraft MSN and the Canopy S/N.

H. Documentation

- (1) Make an entry in the Aircraft Logbook that this Service Bulletin has been incorporated.
- (2) Use the Service Bulletin Evaluation Sheet and report your results and the serial number of the aircraft to Pilatus.

4. Accomplishment Instructions - Spares

Do this procedure on all Canopy Assemblies held as spare with the Serial Numbers given in Para. 1.A.

A. Inspection of the Rivnuts (Ref. Fig. 1)

- (1) Put the flexible borescope through the tooling hole in the right side of the front frame of the canopy.
- (2) Push the flexible borescope into the right side frame until you can see the rivnuts.
- (3) Examine the first four hinge attachment-screw rivnuts (minimum).
- (4) If the rivnuts have a bulge they are correctly installed. Remove the borescope and do the re-identification procedure (Ref. Para. 4.C.).
- (5) If the rivnuts are cylindrical with no bulge they are not correctly installed. Do the rivnut installation procedure for all the rivnuts for the hinge attachment screws (Ref. Para. 4.B.).

B. Installation of the Rivnuts

- (1) Examine all 33 hinge attachment-screw rivnuts for security of attachment. If you find a rivnut that is loose, or has a gap between the countersunk head and the countersink, it is not serviceable. Contact Pilatus Aircraft Ltd. for repair information.
- (2) Do the installation procedure (Ref. Para. 3.D.).

C. Re-identification

- (1) Find the canopy identification placard. The placard is installed:
 - on the rear frame of the canopy
 - or
 - on the side frame of the canopy, near the rear frame.
- (2) Use a suitable indelible marker pen to write 'Post SB 52-005' adjacent to the placard.

D. Reporting Action

Report the results of the inspection to Pilatus Aircraft Ltd. Include the Canopy S/N.

E. Documentation

Make an entry in the spare parts inventory list that this modification has been incorporated.

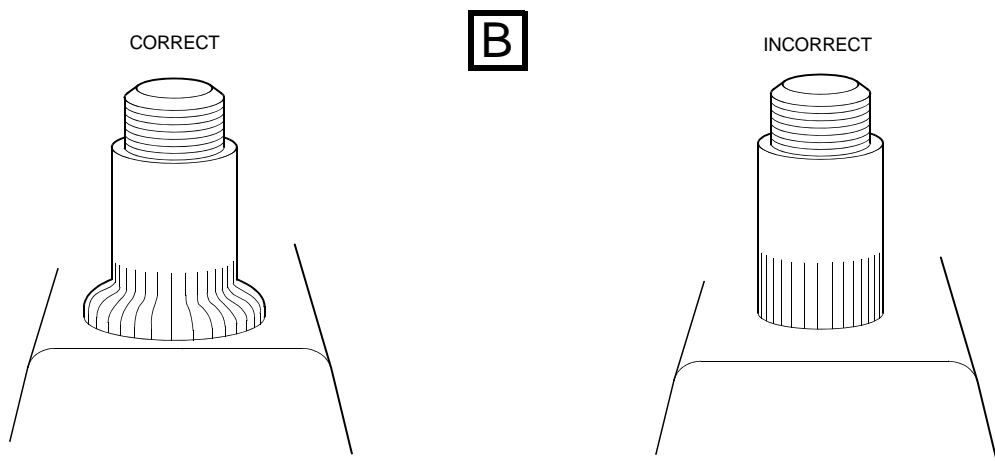
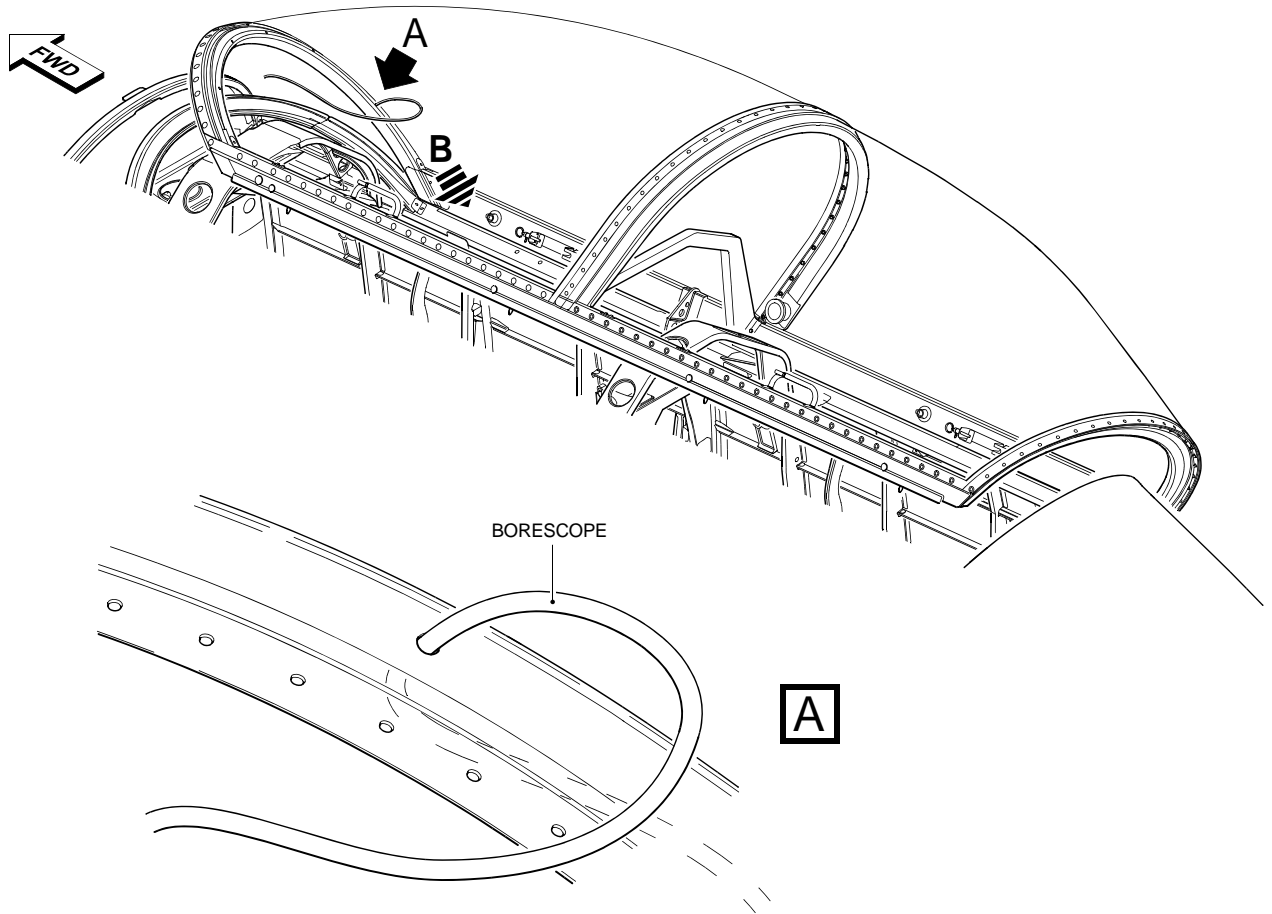

Rivnuts - Inspection
Figure 1

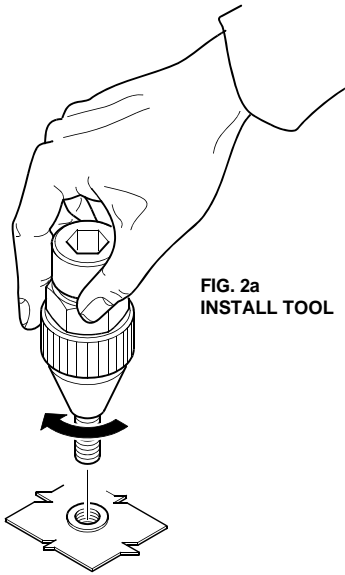
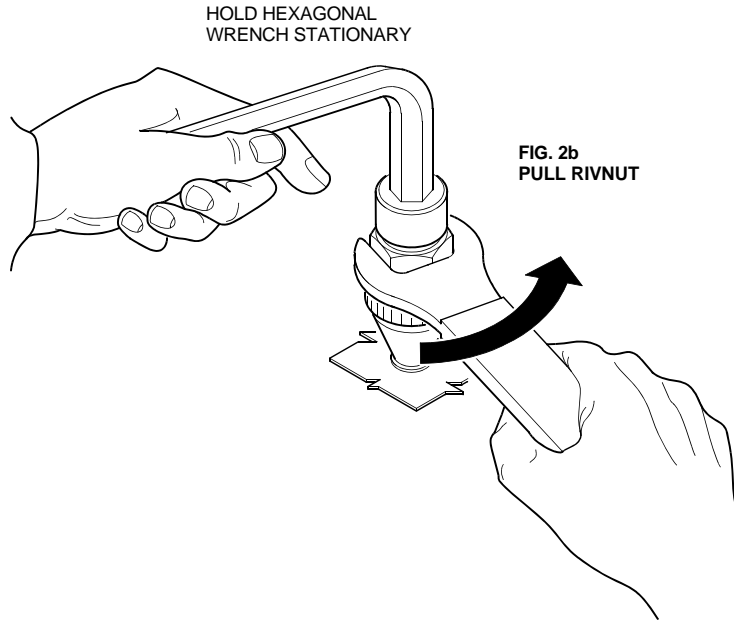
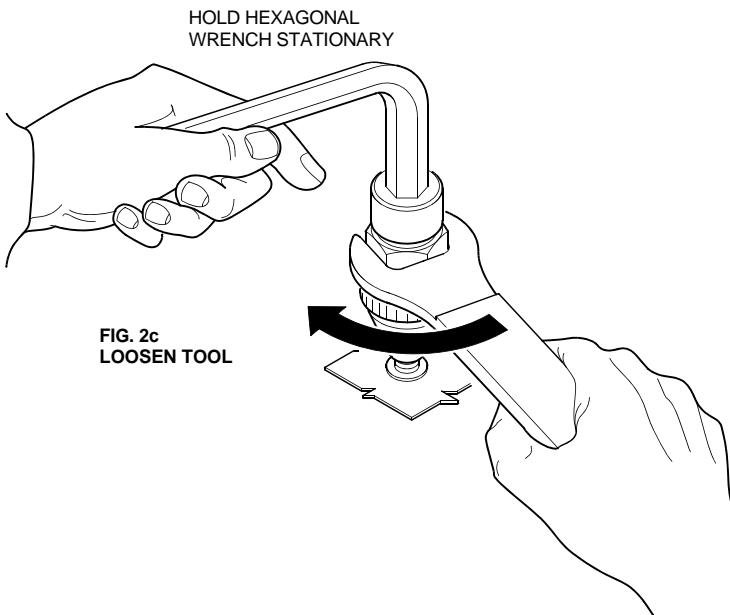

FIG. 2a
INSTALL TOOL



HOLD HEXAGONAL
WRENCH STATIONARY

FIG. 2b
PULL RIVNUT



HOLD HEXAGONAL
WRENCH STATIONARY

FIG. 2c
LOOSEN TOOL

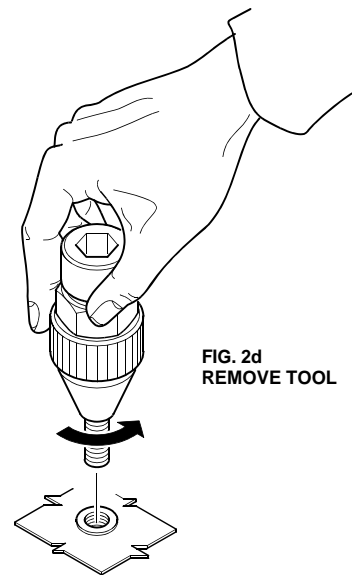

FIG. 2d
REMOVE TOOL

Rivnut Hand Tool - Operation
Figure 2

SB 2492

SERVICE BULLETIN EVALUATION SHEET FOR SB No. 52-005			
Title	Canopy - General - Inspection for Correct Installation of the Hinge Attachment Rivnuts		
Customer			
Service Center			
EMBODIMENT REPORTING			
This SB has been embodied:		<input type="checkbox"/>	On the entire fleet
		<input type="checkbox"/>	Only partially
Provide embodiment details per aircraft (use additional copies of this table, if necessary)			
MSN	Flying Hours	MSN	Flying Hours
Additional embodiment comments/findings			
EDITORIAL COMMENTS (procedure, kit quality, suggested improvements, etc.)			
Name	Signature	Date	
Please complete and forward this form to: Pilatus Aircraft LTD, Customer Technical Support (MCC), P.O. BOX 992, 6371 Stans, Switzerland Fax: +41 (0)41 619 6773 Email: Techsupport@pilatus-aircraft.com			

SERVICE BULLETIN EVALUATION SHEET

INTENTIONALLY BLANK