

Service Bulletin No: 21-009

Ref No: 128

Modification No: EC-14-0379

ATA Chapter: 21

**AIR CONDITIONING - DISTRIBUTION
INSPECT, AND IF NECESSARY, REPLACE THE AIR CONDITIONING HOSES IN THE DE-FOG SYSTEM****1. Planning Information****A. Effectivity**

MSN 010 and MSNs 101 thru 160 (Pre Service Bulletin 21-008 only), MSN 601 thru MSN 604, MSN 608 thru MSN 616 and MSN 675 thru MSN 738.

This modification will be incorporated on MSN 739 and subsequent aircraft during production.

All hoses P/N 917.97.28.202, P/N 917.97.28.206 and P/N 917.97.28.210, held as spare or in stock.

B. Concurrent Requirements

None.

C. Reason**(1) Problem**

Some of the ECS air hoses have experienced delamination problems. This type of hose (type 984) was installed in new production and offered as replacement for in-service hoses. If a hose installed in the de-fog system collapses, it can impair the forward vision from the cockpit.

(2) Solution

Do a one time inspection and replace all the type 984 hose installed in the de-fog system.

NOTE: The color of the type 984 hose is dark grey. The color of the other types of hoses (not affected by this Service Bulletin) is white.

D. Description

This Service Bulletin gives the data and instructions necessary to inspect and replace the type 984 hoses.

E. Compliance

Mandatory.

Accomplishment required not later than 90 days after the effective date of this Service Bulletin.

F. Approval

The technical content of this Service Bulletin is approved under the authority of Letter of DOA Acceptance ref. FOCA.21J.002.

Pilatus advises Operators/Owners to check with their designated Airworthiness Authorities for any changes, local regulations or sanctions that may affect the embodiment of this Service Bulletin.

G. Copyright Information

© Pilatus Aircraft Ltd. This document contains proprietary information that is protected by copyright. All rights are reserved. No part of this document may be copied, reproduced or translated to other languages without the prior written consent of Pilatus Aircraft Ltd.

H. Manpower

	Man-Hours Inspection	Man-Hours Replacement
Preparation	0.50	-
Inspection	0.50	-
Replacement	-	1.50
Close-Up	0.75	-
TOTAL MAN-HOURS	1.75	1.50

I. Weight and Balance

(1) Weight Change

+ 0,087 kg (+ 0.192 lb).

(2) Moment Change

+ 0,275 kgm (+ 1.989 lb ft).

J. Electrical Load Data

Not changed.

K. Software

Not changed.

L. References

Aircraft Maintenance Manual (AMM): 06-20-00, 25-10-00, 34-13-03.

M. Publications Affected

Illustrated Parts Catalog (IPC): 21-20-01.

N. Interchangeability of Parts

One way interchangeable. Pre-Service Bulletin hoses must not be used on post Service Bulletin aircraft.

NOTE: To prevent the installation of pre service bulletin hoses on post service bulletin aircraft, the spare items on stock shall be replaced as per Para. 4.

2. Material Information

A. Material - Price and Availability

Operators who require further information on Price and Availability should contact their Customer Liaison Manager at:

Pilatus Aircraft Ltd,
6371 Stans,
Switzerland.

Operators are requested to advise Pilatus Aircraft Ltd. of the Manufacturer's Serial Number (MSN), the flying hours and landings of aircraft which are allocated for this Service Bulletin using the Service Bulletin Evaluation Form.

Modification Kit Number	Price	Availability
500.50.09.262	Contact address above	Contact address above

B. Material Necessary for Each Aircraft

(1) Material to be Procured

Modification Kit No. 500.50.09.262 has these parts:

NEW PART NO.	DESCRIPTION	OLD PART NO.	QTY	DISP. CODE	FIG	ITEM
917.96.83.051	AIR HOSE	917.97.28.202	1	D	1	5
917.96.83.052	AIR HOSE	917.97.28.206	1	D	1	3
917.96.83.054	AIR HOSE	917.97.28.210	1	D	1	6

Disposition Codes: D - Discard / R - Return to Pilatus

NOTE: Part Numbers given in this Service Bulletin are correct at the time of approval. Pilatus Aircraft Ltd. reserves the right to change the part numbers as necessary. Part numbers of items delivered with the Modification Kit are correct when the kit is dispatched. This could lead to differences between those part numbers quoted in this Service Bulletin and the Modification Kit if parts are superseded. Operators are requested to check the IPC for delivered parts which differ from those listed in the Service Bulletin Materials Kit List.

(2) Operator Supplied Materials:

None.

C. Material Necessary for Each Spare

Refer to Para. 4.

D. Re-identified Parts

None.

E. Tooling - Cost and Availability

None.

3. Accomplishment Instructions - On Aircraft

WARNING: BEFORE YOU GO INTO THE COCKPIT, MAKE SURE THAT BOTH EJECTION SEATS HAVE THE SAFETY PINS INSTALLED IN THE SAFE FOR SERVICING LOCATIONS (REF. AMM, 25-10-00, PAGE BLOCK 201).

A. Preparation

- (1) Open the access panels ENG 3L and ENG 3R (Ref. AMM, 06-20-00, Page Block 001).
- (2) Remove the access panel F3 (Ref. AMM, 06-20-00, Page Block 001).

B. Inspection and Modification (Ref. Fig. 1)

- (1) Do an inspection of the ECS hoses, items (3), (5) and (6).
- (2) If the hoses are dark grey in color, they are type 984 and must be replaced.
- (3) Replace the ECS hoses:

CAUTION: WHEN YOU PUT THE NEW HOSES IN POSITION, MAKE SURE THAT THERE IS CLEARANCE BETWEEN THE HOSES AND THE OTHER SYSTEMS. MAKE SURE THE NEW HOSES DO NOT TOUCH THE WIRE LOOMS, THE SHARP EDGES OF THE TIE WRAPS AND THE SHARP EDGES OF OTHER PARTS.

NOTE: This Step is only applicable to the dark grey (type 984) hoses.

- (a) Remove the ECS hoses:

- 1 Remove the front coaming (1) (Ref. AMM, 34-13-03, Page Block 401).
- 2 Loosen the clamps (2) that attach:
 - The air hose (3) to the air distributor (4)
 - The air hose (5) to the air distributor (4)
 - The air hose (6) to the air distributor (4) and the air distributor assembly (7).

NOTE: The clamps (2) that attach the air hoses (3) and (5) to the front coaming (1) are loosened during the front coaming removal (Ref. Step 3.B.(3)(a)1).

- 3 Move the clamps (2) to the center of:

- The air hose (3)
- The air hose (5)
- The air hose (6).

- 4 Remove:

- The air hose (3)
- The air hose (5)
- The air hose (6).

5 Remove and keep the clamps (2) from:

- The air hose (3)
- The air hose (5)
- The air hose (6).

6 Discard:

- The air hose (3)
- The air hose (5)
- The air hose (6).

(b) Install the new hoses:

1 Put the clamps (2) on:

- The new air hose (5) (P/N 917.96.83.051)
- The air hose (3) (P/N 917.96.83.052)
- The air hose (6) (P/N 917.96.83.054).

2 Put these hoses in position:

- The air hose (5) (P/N 917.96.83.051)
- The air hose (3) (P/N 917.96.83.052)
- The air hose (6) (P/N 917.96.83.054).

3 Put the clamps (2) in the correct position on:

- The air hose (5) (P/N 917.96.83.051)
- The air hose (3) (P/N 917.96.83.052)
- The air hose (6) (P/N 917.96.83.054)

and tighten.

NOTE: Do not tighten the clamps (2) that attach the air hoses (3) and (5) to the front coaming (1). This is done during the front coaming installation (Ref. Step 3.B.(3)(b)4).

4 Install the front coaming (1) (Ref. AMM, 34-13-03, Page Block 401).

C. Close Up

- (1) Remove all equipment, materials and tools from the work area. Make sure that the work area is clean.
- (2) Install the access panel F3 (Ref. AMM, 06-20-00, Page Block 001).
- (3) Close the access panels ENG 3L and ENG 3R (Ref. AMM, 06-20-00, Page Block 001).

D. Documentation

- (1) Make an entry in the Aircraft Logbook that this Service Bulletin has been incorporated.
- (2) Use the Service Bulletin Evaluation Sheet and report your results and the serial number of the aircraft to Pilatus.

4. Accomplishment Instructions - Off Aircraft

- A. Discard all hoses P/N 917.97.28.202, P/N 917.97.28.206 and P/N 917.97.28.210, held as spare or in stock.
- B. Replenish stocks with the new hoses P/N 917.96.83.052, P/N 917.96.83.054 and P/N 917.96.83.051 as per operator requirement.

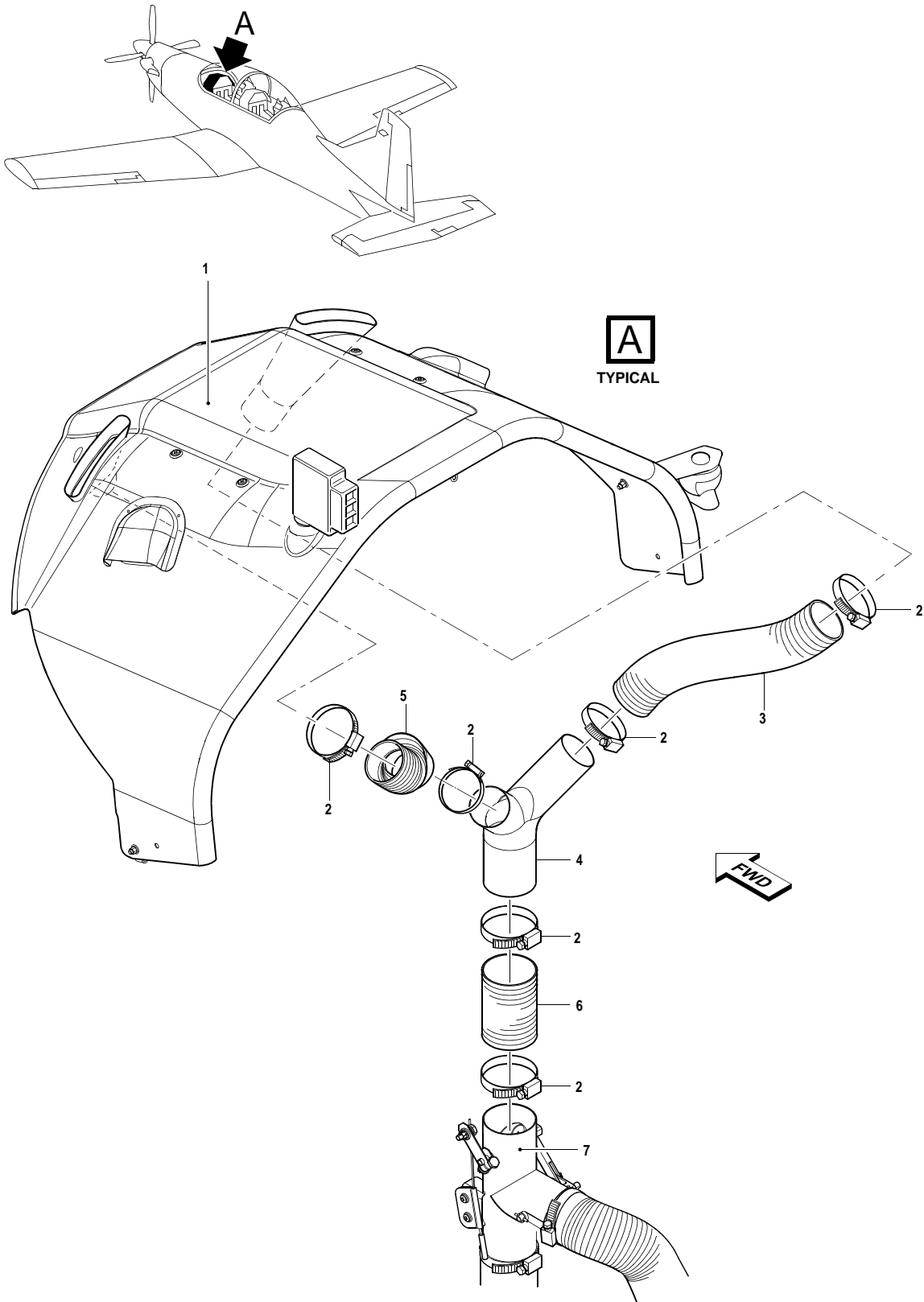

Replacement of the ECS Hoses
Figure 1

SERVICE BULLETIN EVALUATION SHEET FOR SB No. 21-009			
Title	Air Conditioning - Distribution Inspect, and if necessary, Replace the Air Conditioning Hoses in the De-Fog System		
Customer			
Service Center			
EMBODIMENT REPORTING			
This SB has been embodied:		<input type="checkbox"/>	On the entire fleet
		<input type="checkbox"/>	Only partially
Provide embodiment details per aircraft (use additional copies of this table, if necessary)			
MSN	Flying Hours	MSN	Flying Hours
Additional embodiment comments/findings			
EDITORIAL COMMENTS (procedure, kit quality, suggested improvements, etc.)			
Name	Signature	Date	
Please complete and forward this form to: Pilatus Aircraft LTD, Customer Technical Support (MCC), P.O. BOX 992, 6371 Stans, Switzerland Fax: +41 (0)41 619 6773 Email: Techsupport@pilatus-aircraft.com			

SERVICE BULLETIN EVALUATION SHEET

INTENTIONALLY BLANK