

SERVICE BULLETIN

Mandatory

Page 1 of 2

supersedes SB No. 33A

REPLACEMENT OF RUDDER PEDALS

1. Planning Information

1.1 Effectivity:

- Aircraft affected: AS 202 BRAVO
- Serial numbers: 001 - 223 if reinforced pedals not already installed

1.2 Reason: Cracked pedal levers

1.3 Contents of this Bulletin: Replacement of pedal assemblies

- #### 1.4 Compliance:
- For serial numbers 2 to 23, 34, 107 to 109, 112, 124, 127, 129, 130, 134, 135 replacement of assemblies at the next 100h inspection, but not later than June 30, 1990
 - For serial numbers 27 to 29, 103 to 106, 110, 111, 114 to 116, 119 to 122, 128, 136 to 223 not later than March 31, 1991

1.5 Approval: Approved by the Federal Office for Civil Aviation as Airworthiness Directive

1.6 Manpower: - Replacement: 5-6 hrs

1.7 Materials, Cost and Availability: - The material can be obtained from FFA Price and delivery on request

1.8 Tools: - Normal hand tools

1.9 Weight and Balance: - Replacement: Weight + 0,150 kg Arm 2,204 m Moment 0,33 kg m

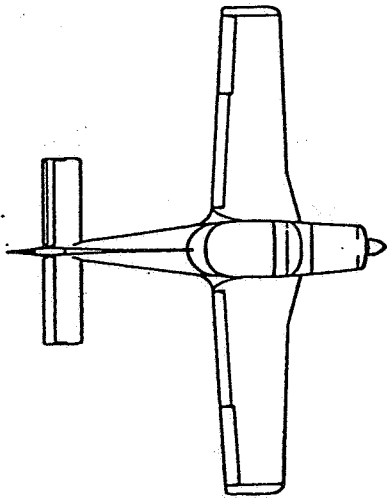

SERVICE BULLETIN

Mandatory

Page 2 of 2

supersedes SB No. 33A

- 1.10 Electric load data: unaffected
- 1.11 Reference to other Publications: Shop Manual, Chapter 27-20-00 (AMM/IPC)
2. Accomplishment Instructions
- 2.1 Preparation:
- Remove control sticks
 - Remove floor plates items 7 and 8 of AMM/IPC, Chapter 53-20-01, Page 0
 - Disconnect cables and rods
- 2.2 Replacement:
- Removal of old pedal assemblies with pedal lever outside dia 17,6 mm
 - Installation of new reinforced pedal assemblies with pedal lever outside dia 20,8 mm
- See AMM/IPC, Chapter 27-20-01, Fig. 02 and 03
- 2.3 Completion:
- Connect and adjust cables and rods
 - Install floor panels
 - Install sticks
- Accomplishment of this SB shall be entered in the Aircraft Technical Log
3. Material
- Torsion tubes 202-16.124 (LH) and 202-16.125 (RH) with reinforced pedal levers may be procured from FFA.