

Lufttüchtigkeitsanweisung
Consigne de navigabilité
Prescrizione di aeronavigabilità
Airworthiness directive

HB 92-403

Inkraftsetzung
Mise en vigueur
Entrata in vigore
Effective Date

02.12.1992

Betroffene Muster - Types concernés - Applicabilità - Models affected

FFA FLUGZEUGWERKE ALTENRHEIN AG - Model AS202/18A, /18A1, /18A2, /18A3, /18A4 aircraft, serial numbers up to and including S/N 236.

Anlass/Massnahmen - Objet/Mesures - Oggetto/Provvedimenti - Subject/Action

FUEL GRAVITY FEED HOSE - Replacement.
FUEL PIPE ASSEMBLY - Replacement / Modification.

Fristen - Délais - Scadenza - Compliance

The effective date on this page is applicable.
Compliance in accordance with FFA Service Bulletin No. 44.

Herkunft - Provenance - Provenienza - Origin

FFA Flugzeugwerke Altenrhein AG.

Bezugnahme - Référence - Riferimento - Reference

FFA Service Bulletin AS202 Bravo No. 44 dated October 31, 1992 (attached to this AD).

Bemerkungen - Observations - Osservazioni - Remarks

Rechtsmittelbelehrung	siehe TM Nr.	F 80.015-10	Seite	von
Voies de droit	voir CT no.		Page	de
Rimedi giuridici	vedi CT no.		Pagina	di
Right to appeal	see CT no.		Page	of

SERVICE BULLETIN

Page 1 of 7

MANDATORY

Improved Fuel Gravity Feed Hose

1. Planning Information

- 1.1 Effectivity: All AS202/18A/18A1/18A2/18A3/18A4 aircraft up to and including serial number 236.
(Note: Some aircraft have Acro feed from right side tank only, some have Acro feed from both left and right side tanks).
- 1.2 Reason: Inconsistency of quality in hoses previously supplied.
- 1.3 Description The existing fuel gravity feed hose is replaced by a braided hose. Due to the replacement hose being less flexible than the existing one, it is necessary to increase its length, and to shorten the length of the rigid tube to which it is attached, in order to retain the original position of the intake valve.
- 1.4 Compliance At the next 100 hour inspection, but not later than end of April 1993.
- 1.5 Approval Approved by the Swiss Federal Office for Civil Aviation as an Airworthiness Directive.
- 1.6 Time required Replacement only - approx. 1.0 hour per aerobatic tank
With rework - approx 2.0 hours per tank.
- 1.7 Material Materials are available from FFA.

FFA Flugzeugwerke
Altenrhein AG
CH-9423 Altenrhein
Schweiz/Switzerland

Telefon 071/43 51 11
Telex 88 29 06 ffa ch
Telefax 071/43 53 30



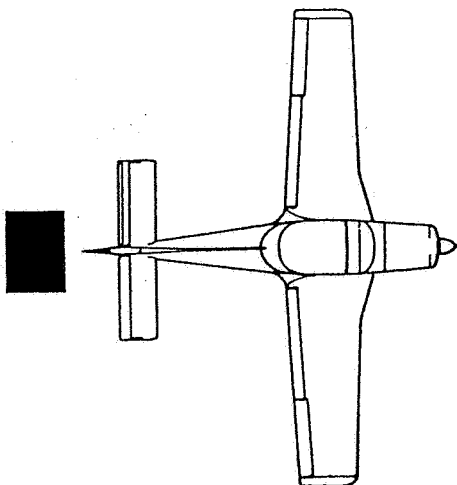

SERVICE BULLETIN

Page 2 of 7

- | | | |
|------|----------------------|---|
| 1.8 | Tooling | Standard tools, and facility for reworking rigid pipe as per diagram. (If rework facilities are not available, replacement parts may be ordered from FFA on an exchange basis). |
| 1.9 | Weight and Balance | Negligible |
| 1.10 | Electrical Load Data | Not affected |
| 1.11 | Applicable Documents | AMM, Chapter 28.
IPC, Chapter 28. |
2. Procedure for AS202/18A1/18A2/18A3/18A4.
- 2.1 Drain fuel from right side or both tanks as necessary.
 - 2.2 Remove inboard fuel level sensor from aerobatic tank(s), having ensured that relevant circuit breakers are OFF.
 - 2.3 Disconnect rigid Acro fuel pipe in each applicable tank from the tank wall fitting and detach the spigots from the pipe support assembly.
 - 2.4 Remove pipe assembly through the level sensor access hole.
 - 2.5 Disassemble and discard the old flexible hose and spring. Retain the intake valve and clamps.
 - 2.6 Obtain new rigid pipe assembly or rework the original pipe as per the attached drawing on page 7. (This involves shortening the tube by 80 mm. and reforming the bulged area). Remove any burrs.

FFA Flugzeugwerke
Altenrhein AG
CH-9423 Altenrhein
Schweiz/Switzerland

Telefon 071/43 51 11
Telex 88 29 06 ffa ch
Telefax 071/43 53 30



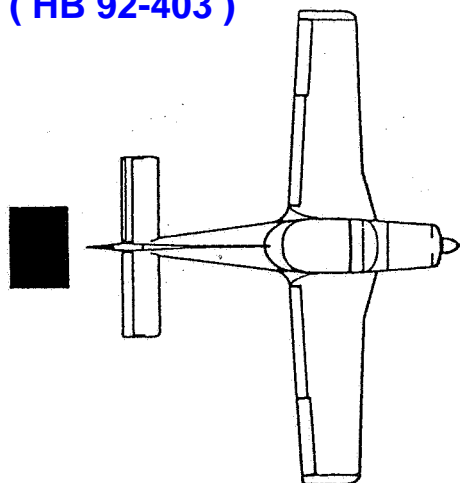

SERVICE BULLETIN

Page 3 of 7

2.7 Assemble the new flexible hose assembly to the dimensions on the accompanying diagram on page 5, using the clamps and intake valve retained in step 2.5.

2.8 Refit the flexible hose assembly and sensor unit.

3. Material

Flexible Hose.	202-18.722.12 (Aeroquip 701-6, length 320 mm).
Suction pipe, LH	202-18.723 replacing 202-18.021 (LH pipe is optional equipment).
Suction pipe, RH	202-18.724 replacing 202-18.022

4. Procedure for AS202/18A aircraft. (Bonded Wing with metallic fuel tank).

4.1 Drain fuel from right side fuel tank.

4.2 Remove the fuel level sensor from the right side fuel tank, having first ensured that the relevant circuit breakers are OFF.

4.3 Disconnect the rigid Acro fuel pipe from the tank wall fitting and detach the spigots from the pipe support assembly.

4.4 Remove the pipe assembly through the level sensor access hole.

4.5 Disassemble, and discard the old flexible hose and spring. Retain the intake valve and clamps.

4.6 Rework the original pipe as per the attached drawing on page 6. (This involves shortening the tube by 80 mm.) Remove any burrs.

AS 202 BRAVO

No.44. 31 October 1992

SERVICE BULLETIN

Page 4 of 7

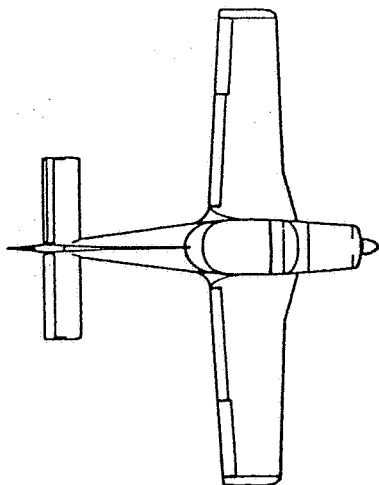

- 4.7 Drill one 2mm hole in the attaching plate as per the accompanying diagram on page 6.
- 4.8 Assemble the new flexible hose assembly to the dimensions on the accompanying diagram on page 5 using the clamps and intake valve retained in step 4.5. Secure the flexible hose by attaching locking wire from the clamp to the 2mm hole in the fuel pipe attaching plate.
- 4.9 Refit the flexible hose assembly and sensor unit.

5. Material

Flexible Hose	202-18.722.12 (Aeroquip 701-6 length 320mm).
Locking wire,	Stainless steel, AISI302, length app.200mm.

6. Recording

Execution of this Service Bulletin shall be entered in the aircraft maintenance log book.

- FOR AIRCRAFT AS202/18A

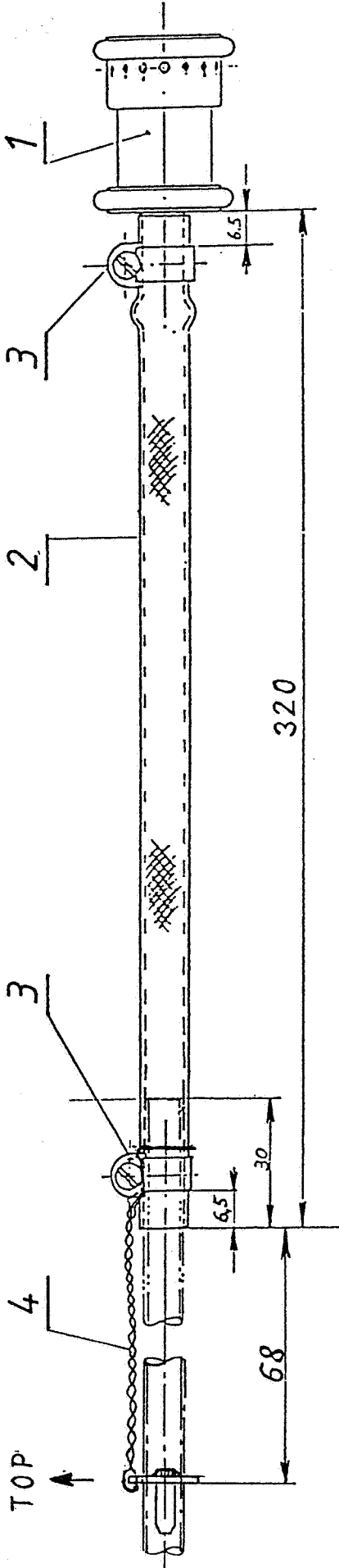

Note: All dimensions are in millimetres (mm)

- FOR AIRCRAFT AS202/18A1/18A2/18A3/18A4

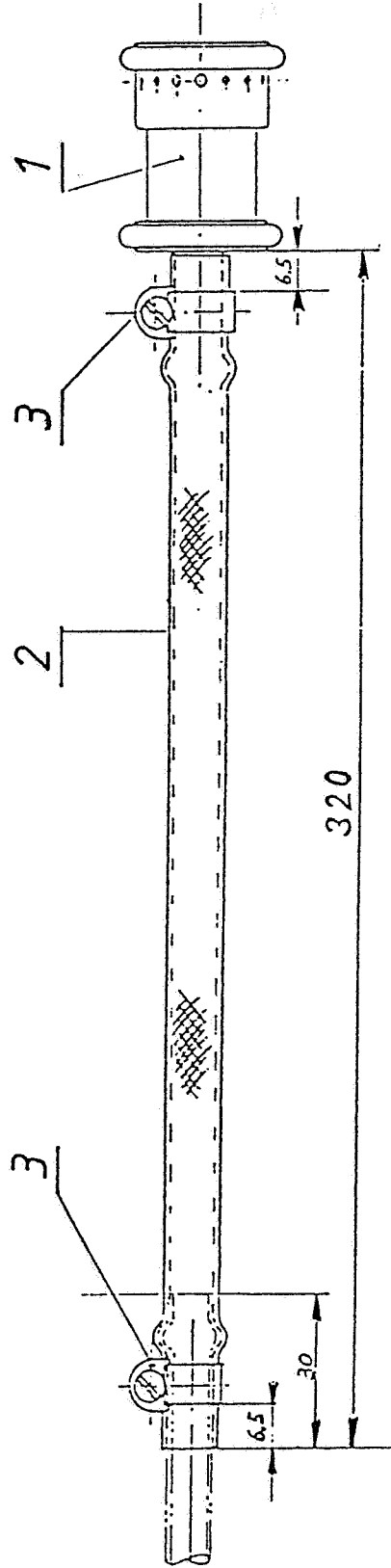

- 1 Intake valve assy 202-18.721
- 2 Flexible hose Aeroquip 701-6
- 3 Clamp Mikroflex Nr.2
- 4 Locking Wire AISI302 0.8 mm

Fuel Gravity Feed Hose Assy. 202-18.722

ACRO FUEL PIPE MODIFICATION FOR AIRCRAFT AS202/18A

(Bonded Wing with metallic fuel tank - RH)

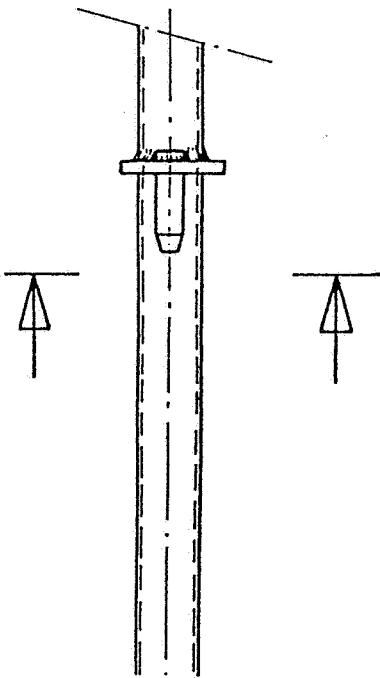
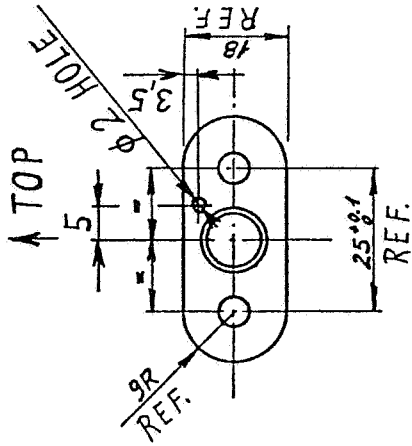

Note: All dimensions are in millimetres (mm)

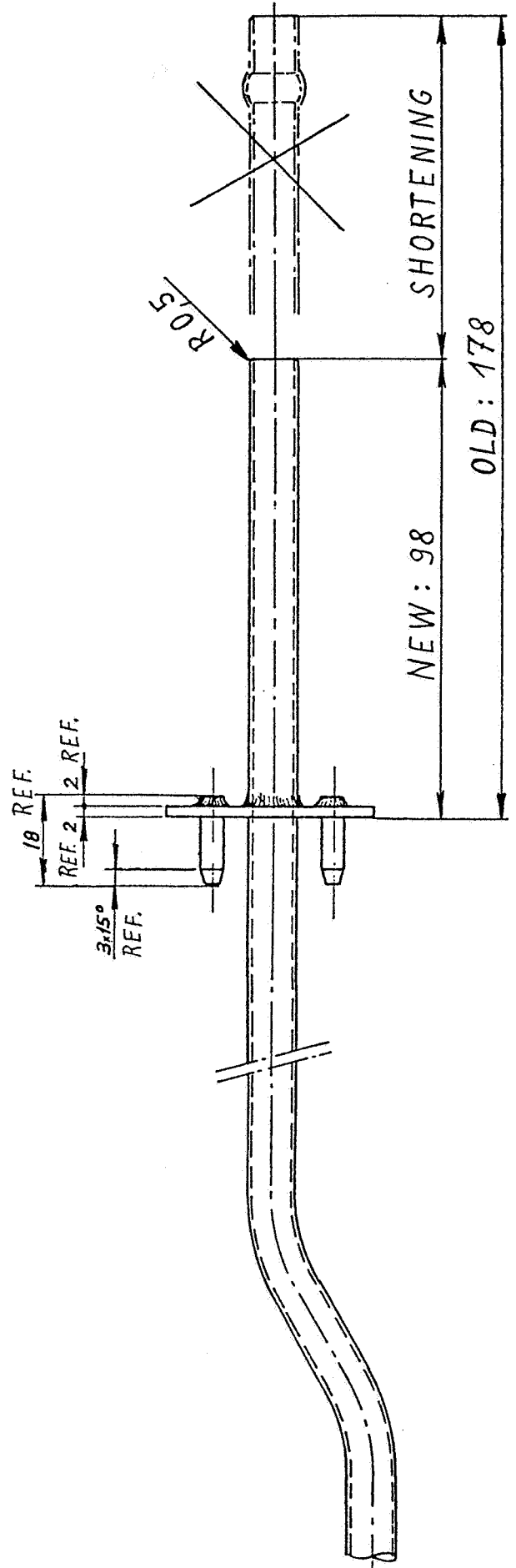

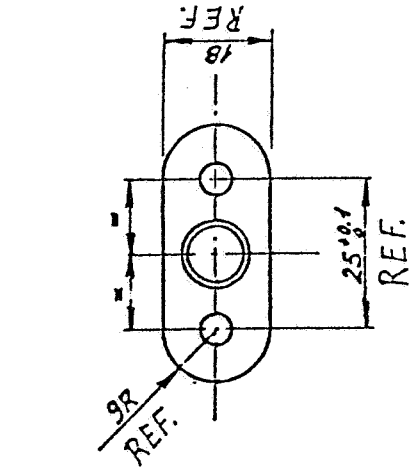

N.B. All dimensions are in millimetres (mm)

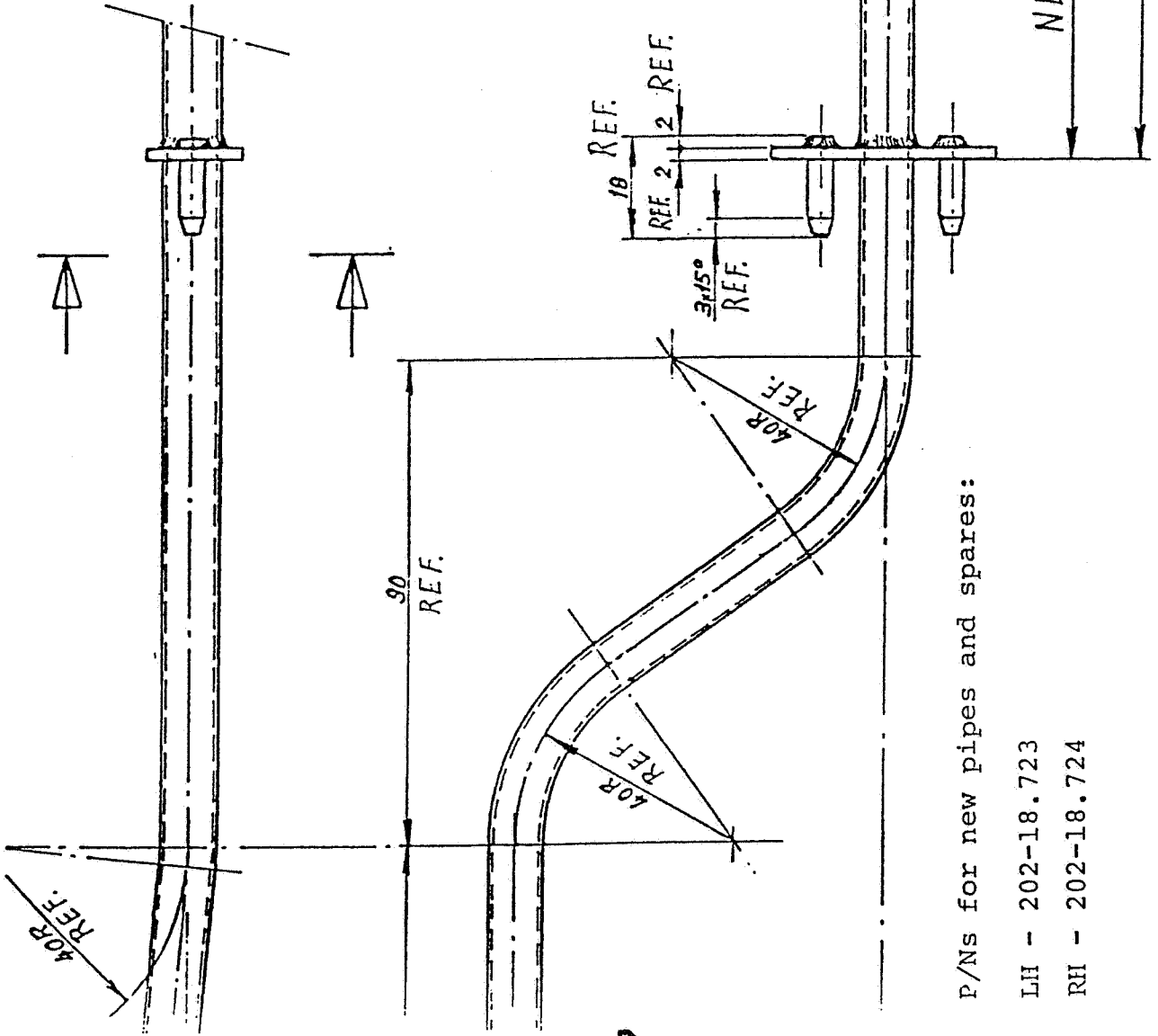

P/Ns for new pipes and spares:

LH - 202-18.723

RH - 202-18.724