



Bundesamt für Zivilluftfahrt (BAZL)
Office fédéral de l'aviation civile (OFAC)
Ufficio federale dell'aviazione civile (UFAC)
Federal Office for Civil Aviation (FOCA)
3003 Bern/Berne/Berna

**Lufttüchtigkeitsanweisung
Consigne de navigabilité
Prescrizione di aeronavigabilità
Airworthiness directive**

HB 91-001

Inkraftsetzung
Date en vigueur
Entrata in vigore
Effective Date

16.1.1991

Betroffene Muster – Types concernés – Applicabilità – Models affected

FFA Flugzeugwerke Altenrhein AG, AS 202/15, AS 202/15-1, AS 202/18, AS 202/18-1, serial number (S/N) 001 → 135, excluding S/N 105 and 106 and airplanes on which the black elevator drive shaft assy has already been replaced since 1988 by the grey painted one

Anlass/Massnahmen – Objet/Mesures – Oggetto/Provvedimenti – Subject/Action

Elevator drive shaft assembly - Corrosion in the tube including the welding inside edge - Replacement of elevator drive shaft assy

Fristen – Délais – Scadenza – Compliance

See FFA Service Bulletin; the effective date on this page is applicable

Herkunft – Provenance – Provenienza – Origin

FFA Service Bulletin

Bezugnahme – Référence – Riferimento – Reference

FFA Service Bulletin AS 202 Bravo No. 41

SUPERSEDED
BY FOCA AD:
HB 91 - 146

Bemerkungen – Observations – Osservazioni – Remarks

Rechtsmittelbelehrung siehe TM Nr.
Voies de droit voir CT no. F 80.015-10
Rimedi giuridici vedi CT no.
Right to appeal see TC no.

Seite
Page
Pagina
Page

1

von
de
di
of

5

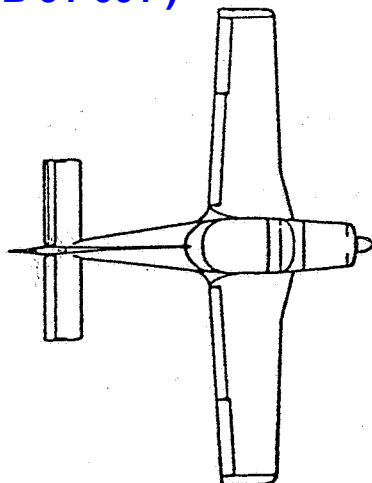

SERVICE BULLETIN

Page 1 of 4

MANDATORY

ELEVATOR DRIVE SHAFT ASSY

1. Planning Information

1.1 Effectivity

- Models: AS 202/15, AS 202/15-1
AS 202/18, AS 202/18-1
- Ser. Nos. S/N 001 to 135
(Excluding S/N 105 and 106 and Airplanes on which the black elevator drive shaft assy has already been replaced since 1988 by the grey painted one)

1.2 Reason: Corrosion in the tube including the welding inside edge

1.3 Description: Replacement of elevator drive shaft assy

1.4 Compliance: At next 100 hours inspection, or within one year.

1.5 Approval: Approved by the Swiss Federal Air Office as Airworthiness Directive

1.6 Manpower: Approx. 5 man-hours

1.7 Material: Available from FFA

1.8 Tooling: No special tools are required

1.9 Weight and Balance: not affected

1.10 Electrical load data: not affected

1.11 Reference to other publications: AMM / IPC, chapter
27-31-04, 27-31-05
55-20-01, 50-50-01
55-20-02

FFA Flugzeugwerke
Allerheiligen AG
CH-9423 Allerheiligen
Schweiz/Switzerland
Telefon 071/430111
Tele: 88 29 06 Nach
Telefax 071/421154

Flugzeuge
Flugzeug-Unterhalt/Repair
Oberflächentechnik
aircraft
maintenance/Repair
surface technology



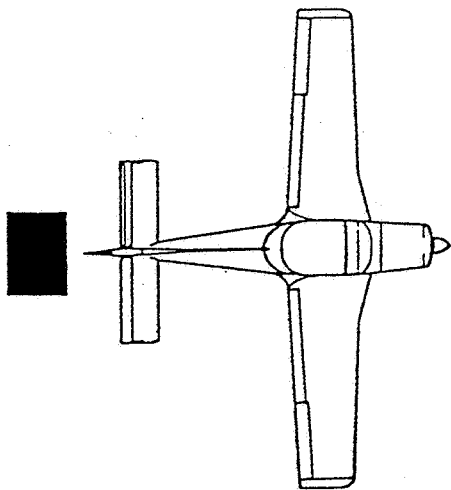

SERVICE BULLETIN

Page 2 of 4

2. Accomplishment Instructions

2.1 Remove

- Remove left cover 202-17.505.11 and right cover 202-17.505.12 on the rear of the fuselage
- Disconnect the elevator steering rod from lever on the drive shaft assy
- Remove covering 202-17.479 of the bearings on the left elevator
- Disconnect the attachment of left elevator on the drive shaft assy
- Remove hinge bolts on the left elevator and carefully remove the left elevator
- Disconnect the middle hinge bolt on the drive shaft assy
- Disconnect the attachment of right elevator on the drive shaft assy and remove the drive shaft assy

2.2 Installation

- Install the new drive shaft assy on the right elevator, see IPC 55-20-01 Page 0, lock the bolts with locking plate and locking wire
- Install the middle hinge bolt on the drive shaft assy, see IPC 55-50-01 Page 0, lock the castellated nut with cotter pin MS 24665-151
- Install the left elevator in position, connect the hinge bolts, see IPC 55-50-01 Page 0, lock the castellated nuts with cotter pin MS 24665-151

FFA Flugzeugwerke
 Allentheim AG
 CH-9423 Allentheim
 Schweiz/Switzerland
 Telefon 071/430111
 Telefax 88 2906 Flach
 Telefax 071/421154

Flugzeuge
 Flugzeug-Unterhalt/Repair
 Oberflächentechnik
 aircraft
 maintenance/Repair
 surface technology



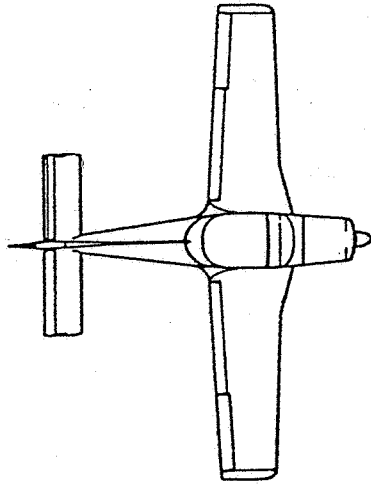

SERVICE BULLETIN

Page 3 of 4

- Attach the left elevator on the drive shaft assy, see IPC 55-20-01 Page 0, lock the bolts with locking plate and locking wire
- Attach the elevator steering rod on the lever of drive shaft assy, see IPC 27-31-04 Page 0 or 27-31-05 Page 0. Lock the castellated nut with cotter pin MS 24665-153
- Install the cover 202-17.479 at the bearings on the left elevator, see IPC 55-20-02 Page 0
- Install the left cover 202-17.505.11 and right cover 202-17.505.12 rear on the fuselage

2.3 Test

- Check the elevator deflection:

For 150 HP airplanes:

up $30^{\circ} \pm 1^{\circ}$
down $20^{\circ} \pm 1^{\circ}$

For 180 HP airplanes:

up $30^{\circ} \pm 1^{\circ}$
down $30^{\circ} \pm 1^{\circ}$

AS202 BRAVO

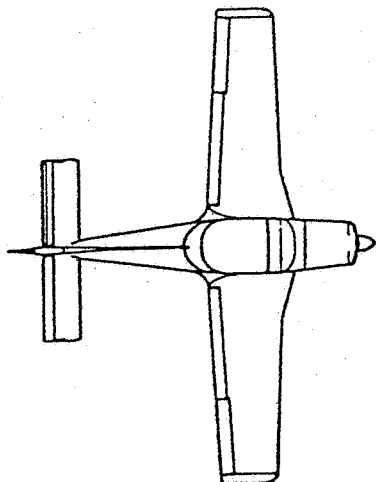

SERVICE BULLETIN

Page 4 of 4

3. Material

For completion of this Service Bulletin the following material is necessary:

- 1 piece Elevator drive shaft assy 202-17.450
- 1 piece Cotter pin MS 24665-153
- 2 pieces Cotter pin MS 24665-151
- 2 pieces Locking wire MS 20995-NC32
(length approx. 12" $\hat{=}$ 300 mm)
- 2 pieces Locking plate 202-17.475

The accomplishment of this Service Bulletin should be recorded in the technical document of the airplane.

FFA Flugzeugwerke
Allentheim AG
CH-9423 Allentheim
Schweiz/Switzerland
Telefon 071/430111
Telex 882906 Flach
Telefax 071/421154

Flugzeuge
Flugzeug-Unterhalt/Repair
Oberflächentechnik
aircraft
maintenance/Repair
surface technology

